

Tivoli® NetView® for z/OS™



Customization Guide

Version 5 Release 1

Tivoli® NetView® for z/OS™



Customization Guide

Version 5 Release 1

Tivoli NetView for z/OS Customization Guide

Copyright Notice

© Copyright IBM Corporation 1997, 2002. All rights reserved. May only be used pursuant to a Tivoli Systems Software License Agreement, an IBM Software License Agreement, or Addendum for Tivoli Products to IBM Customer or License Agreement. No part of this publication may be reproduced, transmitted, transcribed, stored in a retrieval system, or translated into any computer language, in any form or by any means, electronic, mechanical, magnetic, optical, chemical, manual, or otherwise, without prior written permission of IBM Corporation. IBM Corporation grants you limited permission to make hardcopy or other reproductions of any machine-readable documentation for your own use, provided that each such reproduction shall carry the IBM Corporation copyright notice. No other rights under copyright are granted without prior written permission of IBM Corporation. The document is not intended for production and is furnished "as is" without warranty of any kind. **All warranties on this document are hereby disclaimed, including the warranties of merchantability and fitness for a particular purpose.**

U.S. Government Users Restricted Rights—Use, duplication or disclosure restricted by GSA ADP Schedule Contract with IBM Corporation.

Trademarks

IBM, the IBM logo, Tivoli, the Tivoli logo, AIX, AD/Cycle, APPN, C/370, CICS, DB2, IMS, KnowledgeTool, Language Environment, LPDA, MVS/ESA, NetFinity, NetView, OPC, OS/2, OS/390, RACF, RS/6000, Tivoli ADSM, Tivoli Enterprise Console, Tivoli Management Framework, Tivoli OPC, Tivoli Plus, Tivoli Professional Services, Tivoli Ready, TME 10, VM/ESA, VSE/ESA, VTAM, z/OS, are trademarks or registered trademarks of International Business Machines Corporation or Tivoli Systems Inc. in the United States, other countries, or both.

Lotus is a registered trademark of Lotus Development Corporation.

Microsoft, Windows, Windows NT, and the Windows logo are trademarks of Microsoft Corporation in the United States, other countries, or both.

UNIX is a registered trademark of The Open Group in the United States and other countries.

Java and all Java-based trademarks are trademarks of Sun Microsystems, Inc. in the United States, other countries, or both.

Other company, product, and service names may be trademarks or service marks of others.

Notices

References in this publication to Tivoli Systems or IBM products, programs, or services do not imply that they will be available in all countries in which Tivoli Systems or IBM operates. Any reference to these products, programs, or services is not intended to imply that only Tivoli Systems or IBM products, programs, or services can be used. Subject to valid intellectual property or other legally protectable right of Tivoli Systems or IBM, any functionally equivalent product, program, or service can be used instead of the referenced product, program, or service. The evaluation and verification of operation in conjunction with other products, except those expressly designated by Tivoli Systems or IBM, are the responsibility of the user. Tivoli Systems or IBM may have patents or pending patent applications covering subject matter in this document. The furnishing of this document does not give you any license to these patents. You can send license inquiries, in writing, to the IBM Director of Licensing, IBM Corporation, North Castle Drive, Armonk, New York 10504-1785, U.S.A.

Programming Interfaces

This publication documents intended Programming Interfaces that allow the customer to write programs to obtain services of Tivoli NetView for z/OS.

Contents

Preface	vii
Who Should Read This Document.	vii
What This Document Contains.	vii
Publications	viii
Prerequisite and Related Documents.	viii
Accessing Publications Online.	viii
Ordering Publications	viii
Providing Feedback about Publications	ix
Contacting Customer Support	ix
Accessibility Information	ix
Keyboard Access.	ix
Conventions Used in This Document	ix
Platform-specific Information	x
Terminology	x
Reading Syntax Diagrams.	xi
Required Syntax	xi
Optional Keywords and Variables	xii
Default Values	xii
Long Syntax Diagrams	xii
Syntax Fragments	xii
Commas and Parentheses	xiii
Highlighting, Brackets, and Braces	xiv
Abbreviations	xv
Chapter 1. Designing Functions	1
Customization Areas.	1
Functions to Consider before Making Modifications	3
Finding Customization Information.	3
Collecting Data	4
Data Storage and Recording	6
Operator Presentation	6
Tasks	7
NetView Program as a System Application Program	7
NetView Program Tasks	7
Program Activity within a Task	8
Queuing Work to NetView Program Tasks	9
Message and Command Buffers	9
Immediate Commands	9
Long-Running Commands.	9
Data Services Commands.	10
Defining User-Written Programs on the Host: Exits and Commands	10
Installation Exit Programs	10
Command Processors and Command Lists	11
Adding Optional Tasks to the NetView Program	12
Choosing a Language	12
Input and Output	12
Performance	13
Stability	13
Testing	13
Speed of Implementation	13
REXX Versus the NetView Command List Language	13
Language Choices by Function	14
Logging	15
Cross-Reference for Message and Environment Functions	15
Customizing PF Keys and Immediate Message Line	23

Modifying CNMKEYS	24
Chapter 2. Customizing the NetView Command Facility Panel	25
Using a Screen Format Definition	25
Screen Format Definition Statements	25
Message Color and Highlighting	28
Chapter 3. Using the VIEW Command	29
Creating Full-Screen Panels	29
General Help Fields	30
Coding the VIEW Command	32
Return Codes from VIEW and BROWSE.	33
Displaying VIEW Return Codes with SHOWCODE	34
Controlling Color and Highlighting of Fields	35
Displaying Variables in Source Panels	40
Compound Symbols	42
Issuing Commands from Command Procedures	43
Creating a Rollable Component with VIEW.	44
Full-Screen Input Capabilities	47
Returning Command Line Input	54
Using PF Keys and Subcommands with VIEW	55
Using PF Keys and Subcommands with the NOINPUT Option	55
Using PF Keys and Subcommands with the INPUT Option	55
Dynamic Update Capabilities	56
Sample of Panel Updating	57
Changing Colors in Browse	59
Chapter 4. Modifying and Creating Online Help Information	63
Locating Help Source Files	63
View-Based Help	64
Window-Based Help	64
Copying and Changing Help Source Files	67
Storing Help Source Files.	68
HELPMAP Facility	68
Displaying New Help Panels	69
Chapter 5. Customizing Session Monitor Sense Descriptions	71
Session Monitor Sense Codes	71
Examples	72
Chapter 6. Customizing Hardware Monitor Displayed Data	75
Modifying Hardware Monitor Nongeneric Panels.	75
Determining a Panel Name	75
Changing Panel Text	78
Nongeneric Alert Messages	80
Using the ACTION Command List	81
Overlaying Recommended Action Numbers	81
Modifying BNJDNUMB, BNJDNAME, and BNJwwwww	82
Changing Color and Highlighting for Hardware Monitor Panels.	85
Selecting the Color Map	86
Modifying the Color Map	86
Prompt Highlight Tokens.	89
Using NMVT Support for User-Written Programming	90
User-Defined Alerts (Nongeneric)	90
User-Defined Alerts (Generic)	91
Building Generic Alert Panels	92
Alerts-Dynamic Panel	94
Recommended Action for Selected Event Panel	95
Event Detail Panel	97
Modifying Generic Code Point Tables	99

Adding or Modifying Resource Types	102
Chapter 7. Modifying Network Asset Management Command Lists	105
VPD Collection from a Single PU.	106
VPD Collection from a Single NetView Domain	107
Focal Point VPD Collection.	107
Customization Considerations.	108
Chapter 8. Customizing the Event/Automation Service.	111
The Event/Automation Service: Overview.	111
Starting the Event/Automation Service.	112
Customizing the Initialization of the Event/Automation Service	112
Defaults for Configurable Settings	112
Customizing the Event/Automation Startup Parameters	115
Customizing the Event/Automation Service Configuration Files	118
Event/Automation Service Output	118
Event/Automation Service Output Log Names	119
Types of Event/Automation Service Output Data	120
Format of Event/Automation Service Output Data	121
Customizing Alert and Message Routing from NetView	122
Running More Than One Event/Automation Service	122
Running Event/Automation Service in Secure Mode	122
Advanced Customization - Translating Data	122
Class Definition Statement Files	123
Encoding Incoming Event Data	124
Alert Adapter Service and Alert-to-Trap Service Data Encoding.	125
Alert-to-Trap Service Data Encoding.	128
Trap-to-Alert Service Data Encoding.	128
Event Receiver Service Data Encoding	129
SELECT Segment of a Class Definition Statement	129
FETCH Segment of a Class Definition Statement	132
MAP Segment of a Class Definition Statement	133
Message Format Files.	134
Encoding Incoming Event Data	135
Format Specifications.	136
Map Rules	138
%INCLUDE Statements	139
Event Receiver Post-CDS Processing.	140
The Input Attribute List	141
The Output Pseudo Event	141
Translating ASCII Text Data	153
Translating SNMP Non-String Data Types	154
Trap-to-Alert Post-CDS Processing	157
Advanced Customization - Trap-to-Alert Forwarding Daemon	157
Alert-to-Trap Post-CDS Processing	158
Chapter 9. NetView Instrumentation.	159
Considerations	159
Customization	159
Starting and Stopping Instrumentation	162
Customizing the Tivoli Enterprise Console	162
ACB Monitor Customization	162
Parts	163
Defining a Focal Point	163
Defining An Entry Point.	165
Starting the VTAM ACB Monitor.	165
Stopping the VTAM ACB Monitor	165
Chapter 10. Writing a Java Application for the NetView 3270 Management Console	167
Writing a NetView 3270 Management Console Host Access Class Library Application	167

Building Host Access Class Library Applications	169
Source Code Preparation	169
Compilation	169
Running the HACL Application	169
Helper Class	169
Sample Applications	170
 Chapter 11. Designing HTML Files for the NetView Web Server	171
Referencing Files and Commands	171
Understanding the Base URL	171
Adding Links to the Portfolio	172
Loading Panels	173
History Log	173
Using REXX to Generate HTML	174
Security Token	174
Migrating Web Browser Support	174
Appendix A. Color Maps for Hardware Monitor Panels.	177
Appendix B. NetView Macros and Control Blocks	181
General-Use Programming Interface Control Blocks and Include Files	181
Product-Sensitive Programming Interfaces	185
Index	187

Preface

This document describes the parts of the NetView[®] program that you can customize and points you to sources of related information.

Who Should Read This Document

This document is intended for system programmers who customize the NetView program.

What This Document Contains

This document is organized into the following sections, which address the modification and development of your own programming enhancements.

“Chapter 1. Designing Functions” on page 1 describes what you need to know before making an addition or change to the NetView program. This chapter also lists facilities and documentation available to help you customize tasks.

“Chapter 2. Customizing the NetView Command Facility Panel” on page 25 describes how to customize your NetView command facility panel. Customizable functions include: color of fields on the panel; color of command area; default colors for held, action, normal and immediate messages; foreground color for messages. Some other customizable functions are: how much information precedes the message text and how much screen is set aside for held and action messages.

“Chapter 3. Using the VIEW Command” on page 29 describes the VIEW command processor used to display full-screen panels from user-written programs.

“Chapter 4. Modifying and Creating Online Help Information” on page 63 describes how to change the content of the online help facility panels in the NetView program.

“Chapter 5. Customizing Session Monitor Sense Descriptions” on page 71 describes how to modify DSIPARM data set members, how to include additional members, and how to include help for sense codes that have additional meaning for a specific application.

“Chapter 6. Customizing Hardware Monitor Displayed Data” on page 75 describes how to modify the presentation of generic and nongeneric alerts.

“Chapter 7. Modifying Network Asset Management Command Lists” on page 105 describes how to customize non-SNA commands and tables.

“Chapter 8. Customizing the Event/Automation Service” on page 111 describes how to customize the event/automation service for multiple platforms, including workstations and z/OS[™] environments.

“Chapter 9. NetView Instrumentation” on page 159 describes how to customize NetView instrumentation, including the topology display subsystem for the NetView management console (NMC).

Preface

“Appendix A. Color Maps for Hardware Monitor Panels” on page 177 contains a table that lists the panel name, panel number, and color map for hardware monitor panels.

“Appendix B. NetView Macros and Control Blocks” on page 181 contains a list of NetView macros, control blocks and include files.

Publications

This section lists prerequisite and related documents. It also describes how to access Tivoli® publications online, how to order Tivoli publications, and how to make comments on Tivoli publications.

Prerequisite and Related Documents

To read about the new functions offered in this release, refer to the *Tivoli NetView for z/OS Installation: Migration Guide*.

You can find additional product information on these Internet sites:

Table 1. Resource Web sites

IBM®	http://www.ibm.com/
Tivoli Systems	http://www.tivoli.com/
Tivoli NetView for z/OS	http://www.tivoli.com/nv390

The Tivoli NetView for z/OS Web site offers demonstrations of the NetView product, related products, and several free NetView applications you can download. These applications can help you with tasks such as:

- Getting statistics for your automation table and merging the statistics with a listing of the automation table
- Displaying the status of a JES job or cancelling a specified JES job
- Sending alerts to the NetView program using the program-to-program interface (PPI)
- Sending and receiving MVS™ commands using the PPI
- Sending TSO commands and receiving responses

Accessing Publications Online

You can access many Tivoli publications online using the Tivoli Information Center, which is available on the Tivoli Customer Support Web site:

<http://www.tivoli.com/support/documents/>

These publications are available in PDF format. Translated documents are also available for some products.

Ordering Publications

You can order many Tivoli publications online at the following Web site:

<http://www.ibm.com/shop/publications/order>

You can also order by telephone by calling one of these numbers:

- In the United States: 800-879-2755

- In Canada: 800-426-4968
- In other countries, for a list of telephone numbers, see the following Web site:
http://www.tivoli.com/inside/store/lit_order.html

Providing Feedback about Publications

We are very interested in hearing about your experience with Tivoli products and documentation, and we welcome your suggestions for improvements. If you have comments or suggestions about our products and documentation, contact us in one of the following ways:

- Send an e-mail to pubs@tivoli.com.
- Complete our customer feedback survey at the following Web site:
<http://www.tivoli.com/support/survey/>

Contacting Customer Support

If you have a problem with any Tivoli product, you can contact Tivoli Customer Support. See the *Tivoli Customer Support Handbook* at the following Web site:

<http://www.tivoli.com/support/handbook/>

The handbook provides information about how to contact Tivoli Customer Support, depending on the severity of your problem, and the following information:

- Registration and eligibility
- Telephone numbers and e-mail addresses, depending on the country you are in
- What information you should gather before contacting support

Note: Additional support for Tivoli NetView for z/OS is available at the NetView for z/OS Web site:

<http://www.tivoli.com/nv390>

Under Related Documents, select **Other Online Sources**.

The page displayed contains a list of newsgroups, forums, and bulletin boards.

Accessibility Information

Refer to *Tivoli NetView for z/OS User's Guide* for information about accessibility.

Keyboard Access

Standard shortcut and accelerator keys are used by the product and are documented by the operating system. Refer to the documentation provided by your operating system for more information.

Refer to *Tivoli NetView for z/OS User's Guide* for more information about keyboard access.

Conventions Used in This Document

The document uses several typeface conventions for special terms and actions. These conventions have the following meaning:

Preface

Bold	Commands, keywords, flags, and other information that you must use literally appear like this , in bold .
<i>Italics</i>	Variables and new terms appear like <i>this</i> , in <i>italics</i> . Words and phrases that are emphasized also appear like <i>this</i> , in <i>italics</i> .
Monospace	Code examples, output, and system messages appear like <code>this</code> , in a monospace font.
ALL CAPS	Tivoli NetView for z/OS commands are in ALL CAPITAL letters.

Platform-specific Information

For more information about the hardware and software requirements for NetView components, refer to the *Tivoli NetView for z/OS Licensed Program Specification*.

Terminology

For a list of Tivoli NetView for z/OS terms and definitions, refer to <http://www.networking.ibm.com/nsg/nsgmain.htm>.

For brevity and readability, the following terms are used in this document:

NetView

- Tivoli NetView for z/OS Version 5 Release 1
- Tivoli NetView for OS/390[®] Version 1 Release 4
- Tivoli NetView for OS/390 Version 1 Release 3
- TME 10[™] NetView for OS/390 Version 1 Release 2
- TME 10 NetView for OS/390 Version 1 Release 1
- IBM NetView for MVS Version 3
- IBM NetView for MVS Version 2 Release 4
- IBM NetView Version 2 Release 3

MVS MVS/ESA[™], OS/390, or z/OS operating systems.

RACF[®]

RACF is a component of the SecureWay[®] Security Server for z/OS and OS/390, providing the functions of authentication and access control for OS/390 and z/OS resources and data, including the ability to control access to DB2[®] objects using RACF profiles. Refer to:

<http://www-1.ibm.com/servers/eserver/zseries/zos/security/racfss.html>

Tivoli Enterprise[™] software

Tivoli software that manages large business networks.

Tivoli environment

The Tivoli applications, based upon the Tivoli Management Framework, that are installed at a specific customer location and that address network computing management issues across many platforms. In a Tivoli environment, a system administrator can distribute software, manage user configurations, change access privileges, automate operations, monitor resources, and schedule jobs. You may have used TME 10 environment in the past.

TME 10

In most product names, TME 10 has been changed to Tivoli.

V and R

Specifies the version and release.

VTAM® and TCP/IP

VTAM and TCP/IP are included in the IBM Communications Server element of the OS/390 and z/OS operating systems. Refer to <http://www.ibm.com/software/network/commserver/about/>.

Unless otherwise indicated, references to programs indicate the latest version and release of the programs. If only a version is indicated, the reference is to all releases within that version.

When a reference is made about using a personal computer or workstation, any programmable workstation can be used.

Reading Syntax Diagrams

Syntax diagrams start with double arrowheads on the left (▶▶) and move along the main line until they end with two arrowheads facing each other (◀◀).

As shown in the following table, syntax diagrams use *position* to indicate the required, optional, and default values for keywords, variables, and operands.

Table 2. How the Position of Syntax Diagram Elements Is Used

Element Position	Meaning
On the command line	Required
Above the command line	Default
Below the command line	Optional

Required Syntax

The command name, required keywords, variables, and operands are always on the main syntax line. Figure 1 specifies that the *resname* variable must be used for the CCPLOADF command.

CCPLOADF

▶▶—CCPLOADF *resname*—————▶▶

Figure 1. Required Syntax Elements

Keywords and operands are written in uppercase letters. Lowercase letters indicate variables such as values or names that you supply. In Figure 2, MEMBER is an operand and *membername* is a variable that defines the name of the data set member for that operand.

TRANSMMSG

▶▶—TRANSMMSG MEMBER=*membername*—————▶▶

Figure 2. Syntax for Variables

Optional Keywords and Variables

Optional keywords, variables, and operands are below the main syntax line. Figure 3 specifies that the ID operand can be used for the DISPREG command, but is not required.

DISPREG



Figure 3. Optional Syntax Elements

Default Values

Default values are above the main syntax line. If the default is a keyword, it appears only above the main line. You can specify this keyword or allow it to default.

If an operand has a default value, the operand appears both above and below the main line. A value below the main line indicates that if you choose to specify the operand, you must also specify either the default value or another value shown. If you do not specify an operand, the default value above the main line is used.

Figure 4 shows the default keyword STEP above the main line and the rest of the optional keywords below the main line. It also shows the default values for operands MODNAME=* and OPTION=* above and below the main line.

RID

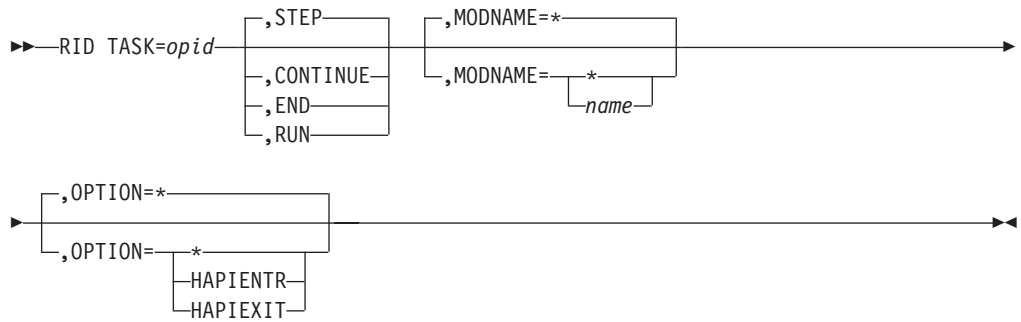

Figure 4. Sample of Defaults Syntax

Long Syntax Diagrams

When more than one line is needed for a syntax diagram, the continued lines end with a single arrowhead (▶). The following lines begin with a single arrowhead (▶), as shown in Figure 4.

Syntax Fragments

Commands that contain lengthy groups or a section that is used more than once in a command are shown as separate fragments following the main diagram. The fragment name is shown in mixed case. See Figure 5 on page xiii for a syntax with the fragments ReMote and FromTo.

BROWSE

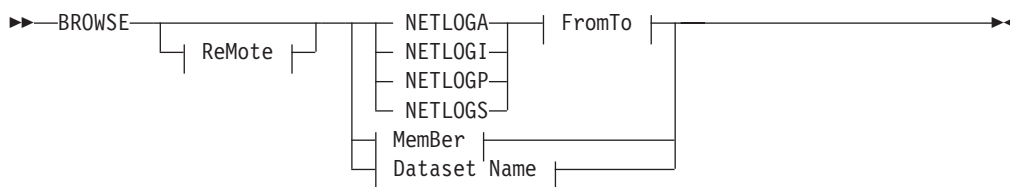

ReMote:

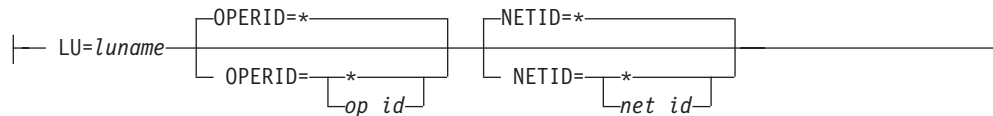

FromTo:

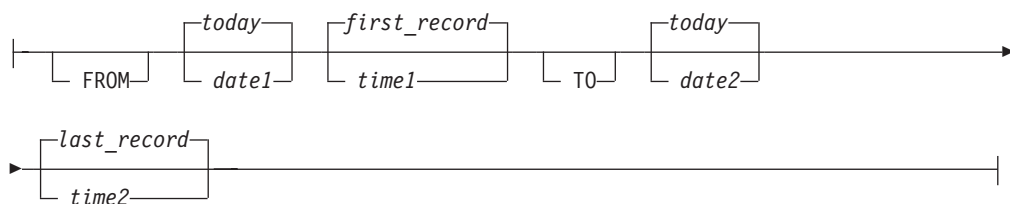

MemBer:

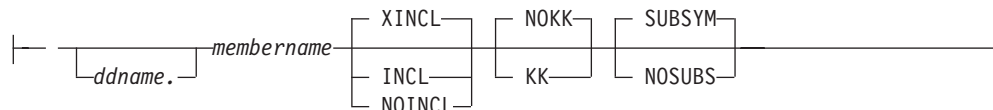

Dataset Name:



Figure 5. Sample Syntax Diagram with Fragments

Commas and Parentheses

Required commas and parentheses are included in the syntax diagram. When an operand has more than one value, the values are typically enclosed in parentheses and separated by commas. In Figure 6 on page xiv, the OP operand, for example, contains commas to indicate that you can specify multiple values for the *testop* variable.

Preface

CSCF



Pu



PurgeAll



PurgeBefore

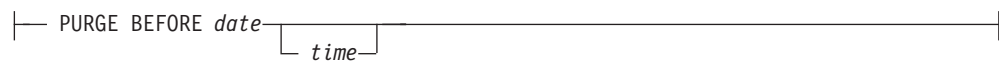

Figure 6. Sample Syntax Diagram with Commas

If a command requires positional commas to separate keywords and variables, the commas are shown before the keyword or variable, as in Figure 4 on page xii.

For example, to specify the BOSESS command with the *sessid* variable, enter:

```
NCCF BOSESS applid,,sessid
```

You do not need to specify the trailing positional commas. Positional and non-positional trailing commas either are ignored or cause the command to be rejected. Restrictions for each command state whether trailing commas cause the command to be rejected.

Highlighting, Brackets, and Braces

Syntax diagrams do not rely on highlighting, underscoring, brackets, or braces; variables are shown italicized in hardcopy or in a differentiating color for NetView help and BookManager® online books.

In parameter descriptions, the appearance of syntax elements in a diagram immediately tells you the type of element. See Table 3 for the appearance of syntax elements.

Table 3. Syntax Elements Examples

This element...	Looks like this...
Keyword	CCPLOADF
Variable	<i>resname</i>
Operand	MEMBER= <i>membername</i>
Default	<u>today</u> or INCL

Abbreviations

Command and keyword abbreviations are described in synonym tables after each command description.

Chapter 1. Designing Functions

NetView enables you to manage complex, multivendor networks and systems from a single point. This chapter describes what you need to know before making an addition or change to the NetView program, and shows some of the facilities available to help you customize tasks.

Customization Areas

Customizing NetView takes place at various stages of network and system implementation. These topics are described in several NetView books. See Table 4 on page 3 for the NetView books that contain more information on the listed topics.

Alias names are used to communicate across networks. You can use alias names to resolve conflicts when duplicate resource names exist in multiple networks. With alias names, the name of the resource, such as a logical unit (LU), a class of service, a source LU (SRCLU), or a LOGON mode table from the sending network, is translated to a name that is unique to the receiving network. Refer to *Tivoli NetView for z/OS Installation: Getting Started* for more information about how to define alias names.

Filtering controls the amount of data presented to operators. Filtering also controls the amount of data recorded in the network log. The NetView automation table allows you to control the types of messages that each of your network operators receives, and the amount of data recorded to message logs. Refer to the *Tivoli NetView for z/OS Automation Guide* for descriptions of automation statements and descriptions of how to use automation statements to suppress (filter) messages.

You can also filter event data that network resources send to the hardware monitor. *Recording filters* control the information that is recorded in the hardware monitor's database. *Viewing filters* determine the records that appear on each network operator's terminal. You can find more information on hardware monitor filtering by referring to *Tivoli NetView for z/OS User's Guide* or *Tivoli NetView for z/OS Automation Guide* for a description of how to use automation statements to set recording filters for specific events. Also refer to the NetView online help for the SRF and SVF commands.

Focal point support enables NetView to be defined as either a focal point node or a distributed entry point node. A focal point is a central network node that receives information from distributed entry point network nodes. The information forwarded from the entry points to the focal point can be messages, alerts, or MSUs. For more information on NetView focal point support, refer to the *Tivoli NetView for z/OS Automation Guide*.

You can use *automation* to implement automatic responses to events that occur in your network. Refer to the *Tivoli NetView for z/OS Automation Guide* for a more information about defining NetView automation statements to improve the productivity of your system and network operators. For additional information the NetView program's automation, refer to the *Tivoli NetView for z/OS Automation Guide*.

Customizing NetView

Use *Generic alerts* and *code points* to obtain problem determination support for devices and applications in your network that the NetView program does not automatically support. “Chapter 6. Customizing Hardware Monitor Displayed Data” on page 75 contains information on how to use the NetView-provided and user-defined code point tables to build hardware monitor Alerts-Dynamic, Alerts-Static, Alerts-History, Event Detail, and Most Recent Events panels.

National Language Support (NLS) allows your operators to interact with the NetView program in a language other than English. Refer to *Tivoli NetView for z/OS Installation: Configuring Additional Components* for a description of how to write your own message translations in any other supported language. The Japanese National Language version provides a Japanese version of NetView panels and messages.

You might need to consider *operator control and security*. To control who can gain access to the NetView program and what effect an operator can have on your network, you should consider some level of logon verification, command authorization, and span of control. Refer to the *Tivoli NetView for z/OS Security Reference* for a complete description of how to implement the different levels of security verification available in the NetView program, how to limit the commands an operator can issue (command authorization), and which part of the network’s resources an operator can control (span of control).

You can modify the color and format of the *NetView command facility panel*. Refer to “Chapter 2. Customizing the NetView Command Facility Panel” on page 25 for more information.

You can create or change *panels* for your online help, online message help, NetView help desk, the hardware monitor, and any user-written, full-screen applications. For a detailed explanation of how to create new panels or modify Tivoli-supplied panels for these components, see “Chapter 4. Modifying and Creating Online Help Information” on page 63 or “Chapter 6. Customizing Hardware Monitor Displayed Data” on page 75.

Sequential logging (sequential access method log support) enables you to write variable length records to multiple user-defined logs. You can browse or print these logs using your operating system facilities. For more information about defining sequential log tasks, refer to the *Tivoli NetView for z/OS Installation: Configuring Additional Components*, *Tivoli NetView for z/OS Customization: Using Assembler*, or *Tivoli NetView for z/OS Customization: Using PL/I and C*.

Session monitor data can be collected and kept in the session monitor database. To control how much session data is collected and kept, customize several session monitor definition statements. Refer to the *Tivoli NetView for z/OS Installation: Configuring Additional Components* for more information. Defining performance classes for the response time monitor (RTM) feature is also described in *Tivoli NetView for z/OS Installation: Configuring Additional Components*. Objectives and boundaries are set for each performance class, and a performance class is then chosen for a session.

User-written functions add new function to the NetView program or modify existing ones. You might want to develop your own command lists and user-written code. Refer to the *Tivoli NetView for z/OS Customization: Using REXX and the NetView Command List Language* for an overview of writing command lists in REXX or in NetView command list language to help you control your network and make the operators’ jobs easier. You can find information about writing code

such as command procedures and installation exits in *Tivoli NetView for z/OS Customization: Using PL/I and C*. Information on writing command processors, installation exit routines, and user subtasks in assembler language can be found in *Tivoli NetView for z/OS Customization: Using Assembler*.

The NetView **Resource Object Data Manager (RODM)** is a data cache that stores network configuration and status information about system resources. RODM enables you to automate network management functions associated with the resources defined to RODM. In addition, you can write RODM applications to perform other network management and automation tasks. Refer to the *Tivoli NetView for z/OS Resource Object Data Manager and GMFHS Programmer's Guide* for more information.

Functions to Consider before Making Modifications

To customize NetView functions, you can write your own command procedures or modify one of the existing command procedures supplied by the NetView program. Ways to modify existing functions include:

- Filtering or modifying the system management facility (SMF) records written by NetView
- Providing a policy that routes operator messages
- Reformatting, analyzing, or editing operator messages
- Checking command authority

Additional functions you might want to add involve managing additional components in your network, such as X.25 data network components or voice network components. You can develop new applications and integrate them with existing management functions to meet your requirements. Examples of these user-defined functions include:

- Real-time monitoring of specific resources, applications, or components in your network
- Collecting and recording additional SMF data for trend analysis or other data reduction applications you need
- Providing additional response time problem detection and alerting
- Detecting different classes of line problems and providing switched network backup (SNBU).

Finding Customization Information

Table 4 lists customization topics and provides the name of the documentation that includes information about that topic.

Table 4. Customization Topics and Documentation

Topic	CGD	GET	OLH	CLS	PLC	ASL	AUT	PIP	ASR	NUG	ADV
Alias names		X							X		
Command Facility Screen Format	X								X	X	
Automation							X			X	X
Generic alerts	X						X				

Customizing NetView

Table 4. Customization Topics and Documentation (continued)

Topic	CGD	GET	OLH	CLS	PLC	ASL	AUT	PIP	ASR	NUG	ADV
National Language Support											X
Operator control: Logon security Command security Span of control									X X X		
Panels: Hardware monitor* Help Help desk User-written	X X X X									X X X X	
Sequential logging	X				X	X					X
Session monitor data:* Response time monitor monitor Session awareness											X X
Suppressing: Message Hardware monitor*				X			X X		X		
User-written functions: Command lists User-written programming (PL/I, C) User-written programming (assembler) NetView Pipelines				X		X					
Legend: CGD <i>Tivoli NetView for z/OS Customization Guide</i> GET <i>Tivoli NetView for z/OS Installation: Getting Started</i> OLH <i>NetView online help</i> CLS <i>Tivoli NetView for z/OS Customization: Using REXX and the NetView Command List Language</i> PLC <i>Tivoli NetView for z/OS Customization: Using PL/I and C</i> ASL <i>Tivoli NetView for z/OS Customization: Using Assembler</i> AUT <i>Tivoli NetView for z/OS Automation Guide</i> PIP <i>Tivoli NetView for z/OS Customization: Using Pipes</i> ASR <i>Tivoli NetView for z/OS Administration Reference</i> NUG <i>Tivoli NetView for z/OS User's Guide</i> ADV <i>Tivoli NetView for z/OS Installation: Configuring Additional Components</i> *											

For information about customizing AON, refer to the *Tivoli NetView for z/OS Automated Operations Network Customization Guide*.

Collecting Data

Typical sources for collecting data useful in customization procedures are:

- Installation exit interfaces provided in the NetView program
- System or NetView services that provide status, configuration, processing, or authorization information

- Data files and network devices that are accessed using system or NetView services
- Messages to operators indicating that important events are occurring in a system or an application.

Installation Exits

Some NetView installation exits allow access to network management data. Through these installation exits, and user-written functions you can obtain the text of operator commands, messages, and logons. Data that the NetView program writes to VSAM files and to the SMF log, as well as data on the VTAM communication network management (CNM) interface, can be accessed within other NetView installation exits.

Reference: For more information about NetView installation exits, refer to the *Tivoli NetView for z/OS Automation Guide*, *Tivoli NetView for z/OS Customization: Using Assembler*, and *Tivoli NetView for z/OS Customization: Using PL/I and C*.

Service Routines

System or NetView services give you access to information such as:

- System date and time
- Addresses of programs
- Addresses of named storage areas
- Valid NetView operators
- Operator span of control
- Values of command list variables.

Reference: Refer to the *Tivoli NetView for z/OS Customization: Using Assembler* for information about macros such as DSIDATIM, DSICES, DSIFIND, DSIQOS, DSIQRS, and DSIKVS. Refer to the *Tivoli NetView for z/OS Customization: Using PL/I and C* for information on service routines such as CNMINFC, CNMNAMS, CNMSCOP, and CNMVARs.

Data Files

The NetView program provides specialized disk services and VSAM data services to access network management data files. In addition to these, functions written in a high-level language (HLL), such as PL/I and C, can invoke system allocation and access methods to read from NetView partitioned data sets and request VSAM I/O. CNM interface services also provide access to data coming from devices in the network.

Using the NetView PIPE command, you can read data files using the QSAM and < (From Disk) stages. Through the pipe facility, you also have access to VSAM data using DSIVSAM and DSIVSMX. Refer to the *Tivoli NetView for z/OS Customization: Using Pipes* for information about DSIVSAM and DSIVSMX.

REXX command lists can make use of the EXECIO command to read from and write to sequential data sets or partitioned data set members.

Reference: Refer to the *Tivoli NetView for z/OS Customization: Using PL/I and C* for information about VSAM and CNM interface services.

For more information about pipes, refer to the *Tivoli NetView for z/OS Customization: Using Pipes*.

Customizing NetView

Refer to the *Tivoli NetView for z/OS Customization: Using REXX and the NetView Command List Language* for information on REXX file input and output. Refer to the *Tivoli NetView for z/OS Customization: Using Assembler* for information on using DSIDKS for read access to NetView data sets or files, DSIZVSMS for VSAM I/O, and DSIZCSMS for CNM data services.

Operator Commands and Messages

You can issue operator commands within command procedures to request status data. The resulting response messages containing the requested status data can be trapped and processed in the command procedure. You can also process data in other system and network messages in user-written command procedures that are invoked through NetView automation.

Reference: Refer to the *Tivoli NetView for z/OS Customization: Using REXX and the NetView Command List Language* for information on REXX and NetView command list language message processing. Refer to the *Tivoli NetView for z/OS Customization: Using PL/I and C* for information on PL/I and C message processing. For more information on writing automation options, refer to the *Tivoli NetView for z/OS Automation Guide*.

Data Storage and Recording

You can use NetView command procedures to store and retrieve data needed for many user-written functions. Command procedures written in REXX, NetView command list language, PL/I, or C can create, set, and read global and task variables.

For permanent storage and for larger volumes of data, you can record certain information in data files rather than naming it and storing it as a command list variable. The NetView program allows you to record this data in a log. For example, you can log activities of your applications along with system or network activities that the NetView program is logging. You might want to produce a separate log of data that you collect.

Reference: Refer to the *Tivoli NetView for z/OS Installation: Configuring Additional Components* and “Choosing a Language” on page 12 in this book for information on sequential logging.

Operator Presentation

You can customize or extend some of NetView’s operator presentation functions with the VIEW command or by modifying panels that some components of NetView use to present data to operators. See “Chapter 3. Using the VIEW Command” on page 29 and “Chapter 4. Modifying and Creating Online Help Information” on page 63 for more information.

You can also use messages to present information to operators. With messages, the data from user-written functions becomes subject to NetView automation processing, allowing both automatic and manual operation of your functions.

Reference: Refer to the *Tivoli NetView for z/OS Customization: Using Assembler* for information about DSIWCS, DSIMBS, DSIMQS, DSIPSS, and other message services. Refer to the *Tivoli NetView for z/OS Customization: Using PL/I and C* for information about using CNMSMSG. Refer to the *Tivoli NetView for z/OS Customization: Using REXX and the NetView*

Command List Language for descriptions of REXX and NetView command list language write-to-operator (WTO) messages and other message services.

You can also customize the NetView command facility panel. See “Chapter 2. Customizing the NetView Command Facility Panel” on page 25 for more information.

Tasks

To write functional extensions to the NetView program, keep in mind that the NetView design is based on MVS.

Reference: The *MVS/ESA* library is a good reference for explanations of how words such as *dispatch*, *task*, and the names of various system services are used in this section.

NetView Program as a System Application Program

The NetView program is organized into several parallel tasks, each one capable of being dispatched separately in a multitasking environment. When any one task is idle, any of the others is eligible to run. A system multitasking dispatcher uses the NetView program’s ATTACH system service to create each new task. When a task has no more processing to do and is ready to become idle, the task calls the WAIT system service. The POST system service takes a task out of an idle state, and allows it to be dispatched when new input data is ready to be processed for that task.

NetView Program Tasks

When the NetView program starts, its main task attaches several subtasks of different types, depending on the function to be performed. Each different task type determines the specific system interfaces and operator interfaces that are available under that task, and the type of transactions you can perform.

Each operator station task (OST) supports one NetView operator identified by a unique name. The operator identifiers (OPIDs) are defined in the NetView parameter library. OPIDs are assigned to an OST when an automated operator, known as an autotask, is activated using the AUTOTASK command, or when an operator logs on using a VTAM-connected terminal.

Each NetView-NetView task (NNT) also supports an operator. This type of task is used when the operator logs on to the NetView program from another NetView program rather than from a terminal. The other NetView program can be running in a different machine but must be connected through VTAM. The operator logs on from the other NetView program using the START DOMAIN command.

Each hardcopy task (HCT) supports a 3287 printer connected through VTAM to provide a hardcopy log for operators. See Figure 7 on page 8 for a structural overview of the command facility and its task structure.

Customizing NetView

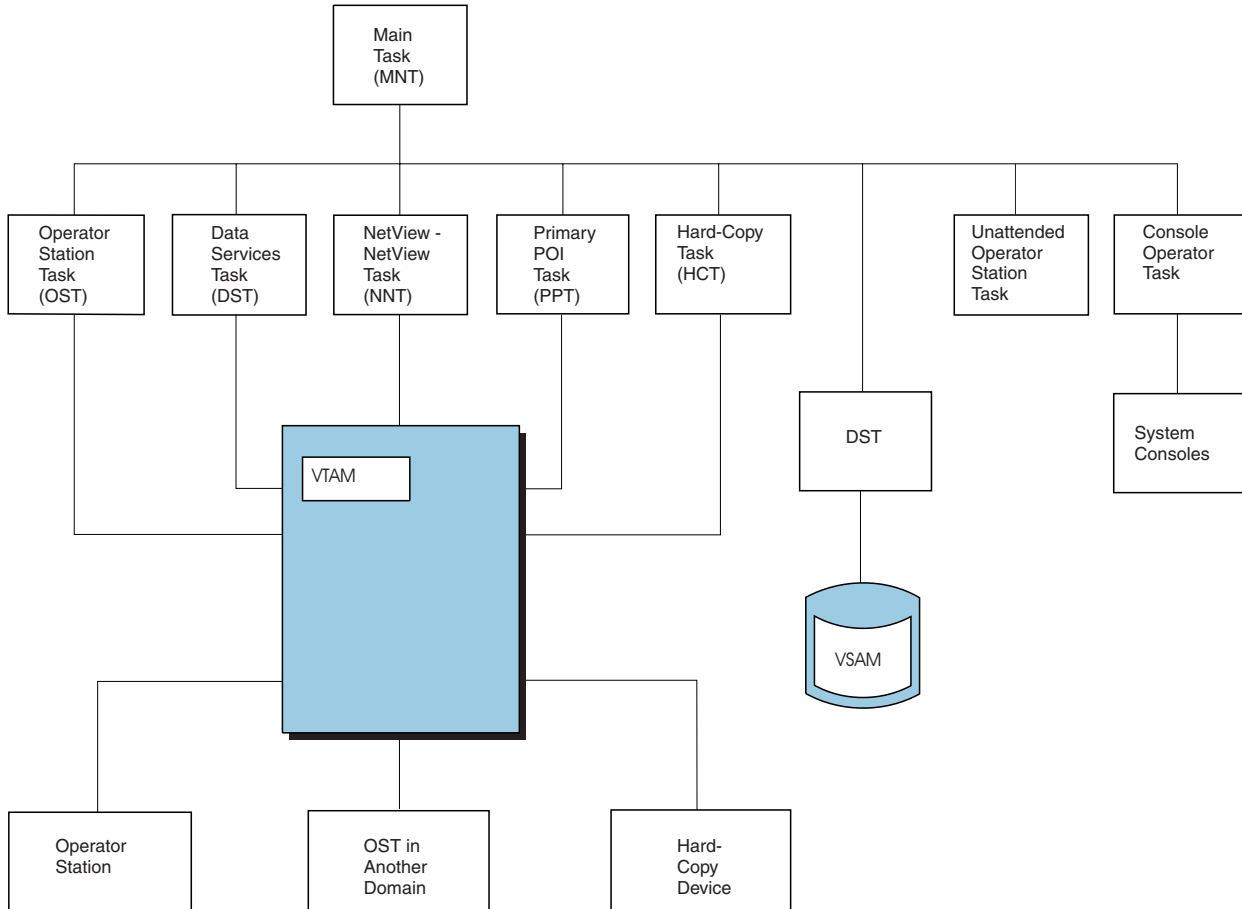

Note: NetView can also run when VTAM is not active.

Figure 7. Structural Overview of the Command Facility

There is only one primary program operator interface task (PPT) for each NetView program. When VTAM is running, the PPT opens a special VTAM application control block (ACB) for the VTAM programmable operator interface (POI) to receive unsolicited data from VTAM.

Each optional task (OPT) must be defined by a TASK statement in the NetView parameter library. The program module that runs for an OPT can be any program that meets the specification for optional tasks described in “Adding Optional Tasks to the NetView Program” on page 12.

Each data services task (DST) is a specific case of an optional task. See “Adding Optional Tasks to the NetView Program” on page 12. The TASK statement for a DST can name an initialization member in the NetView parameter library from which statements are read to define parameters for the functions performed by the specified DST.

Program Activity within a Task

After being activated, each type of NetView task waits for a request to perform a specific unit of work. When that unit of work is complete, the task enters a normal wait state. The task runs again when another request to perform a unit of work is received. Each task uses a list of event control blocks (ECBs) when it issues its WAIT. The NetView customization macros and services are provided to ensure that

any implied waiting is done through the ECB list of the task so that all of the task-request interfaces within the NetView program remain enabled.

Every NetView task has its own termination ECB and its own message queue ECB. Some types of tasks (for example, OSTs or DSTs) can have additional ECBs in their ECB lists. The additional ECBs represent processing that the task tests for and performs when it is posted out of its WAIT state.

Queuing Work to NetView Program Tasks

While a task is in its normal WAIT state, another task in the NetView program can run. A NetView task that is running can be interrupted at any time by an event in the system, and can be preempted by a higher-priority task until that task issues its normal WAIT. System functions outside of the NetView program can also interrupt the NetView processing by running scheduled interrupt exit routines that are associated with specific NetView tasks.

Data for a task can be placed in its message queue or another work queue, and the task can be posted to perform that work at any time. The data can originate in another NetView task. This can happen when a DST queues message data to an OST to be displayed to an operator. The data can come into the NetView program through an interrupt exit routine that is scheduled by an event such as the completion of a VTAM RECEIVE request.

Message and Command Buffers

The data placed in the various task queues is formatted into a special data structure called a message buffer or a command buffer. A header at the beginning of the buffer indicates the type of data the buffer contains and any special formats by which the data must be accessed. Commands are processed by programs called command processors that you provide in your customization programming for the NetView program. Messages are processed either according to predefinitions built into the NetView task, or by NetView automation command processors. Message buffers are also available for automation at various points in NetView processing through installation exits.

Immediate Commands

An immediate command starts processing as soon as an operator enters the command. The requested function is performed immediately, even if the task is in the middle of a large queue of work.

An immediate command runs under the OST and NNT subtask environments. Unlike other commands, immediate commands can receive control with the TVBINXIT bit set on. Immediate commands interrupt mainline processing and cannot be interrupted by another command. Immediate commands can be interrupted by other exits in asynchronous activity.

Long-Running Commands

A long-running command is a command that can suspend processing to allow other activity, such as operator commands and data retrieval, and then resume processing. All the NetView components are long-running commands. NetView command list language, REXX, PL/I, and C command procedures are also long-running commands. The DSIPUSH macro allows an assembler command to run as a long-running command.

Customizing NetView

Long-running commands run under an OST, NNT, PPT, or DST (logoff routines only). Long-running commands can be:

- Invoked directly by operator input
- Called by a command list
- Called by another long-running command.

Long-running commands return control to the NetView program after scheduling work but before processing is complete. The NetView program then processes other work that is pending.

You can use long-running command processors to retrieve data from another task or from another domain without allowing the calling function or calling command list to proceed during the retrieval. When the retrieval is executing, the processor's task can continue to receive messages and accept commands.

Data Services Commands

A data services command processor (DSCP) runs under the DST subtask environment. DSCPs perform CNM data services and VSAM data services. DSCPs can also be called for centralized or serialized user-defined functions that do not use CNM interface or VSAM services.

Defining User-Written Programs on the Host: Exits and Commands

You can provide two types of user-written programs within the NetView task environments:

- Installation exits
- Command processors.

Reference: The programming interface details are provided in *Tivoli NetView for z/OS Customization: Using PL/I and C* and *Tivoli NetView for z/OS Customization: Using Assembler*. In designing user-written functions, you can use the installation exit interface and the command processor interface in the NetView program to fit your own programming into the overall structure of the NetView program.

Installation Exit Programs

Installation exits are provided in NetView at several points in the processing of logon and logoff data, command buffers, and message buffers. Different exits are driven based on the origin of the buffer and the stage of the NetView processing that the exit is in. Special exits are driven under DSTs to handle a task's data during initialization, input, and output.

Reference: For a summary of the NetView installation exits, refer to the *Tivoli NetView for z/OS Automation Guide*, *Tivoli NetView for z/OS Customization: Using Assembler*, and *Tivoli NetView for z/OS Customization: Using PL/I and C*.

General installation exits are identified and invoked with preassigned module names of DSIEX m , and the DST exits are uniquely identified in the task DSTINIT initialization statements.

DSIEX21 is used to access the DSITCPRF member. For more information, refer to the *Tivoli NetView for z/OS Security Reference*.

Command Processors and Command Lists

NetView command processors and command lists can be started by:

- An operator request
- A command buffer queued to a task for processing by any NetView program
- A command call from another command processor
- An action specified in the NetView automation table.

Reference: To define command lists written in the NetView command list language or REXX to the NetView program, place them in the NetView command list library (*ddname* DSICLD). Refer to the *Tivoli NetView for z/OS Customization: Using REXX and the NetView Command List Language* to find out how to create command lists for specific operating systems.

You must link-edit PL/I, C, and assembler command processors into the NetView load library (*ddname* STEPLIB), and define them to NetView. To define command processors written in PL/I, C or assembler to NetView, use a CMDMDL statement in the DSICMD member of DSIPARM. Command processors are link-edited into the NetView load library.

You can implement parts of a function in multiple installation exit programs and command processors. A common way of splitting a function across command processors is to divide processing between OSTs and DSTs. Because OSTs receive data from operator stations and return data back to them, a command processor is written to:

- Be called when the command is entered by an operator
- Parse the command data and form a data services request
- Queue a command buffer containing the data services command to be processed by the DST
- Return an error message or a command confirmation message to the operator

The DST completes the function in a separate command processor that is called because of the command buffer that is built and queued by the first command processor. Under the DST, functions requiring the special data services of VSAM, external logging, or the VTAM CNM interface are performed and messages can be returned to the operator task that queued the command. Figure 8 on page 11 shows a typical program design for a function that uses the CNM interface and VSAM services.

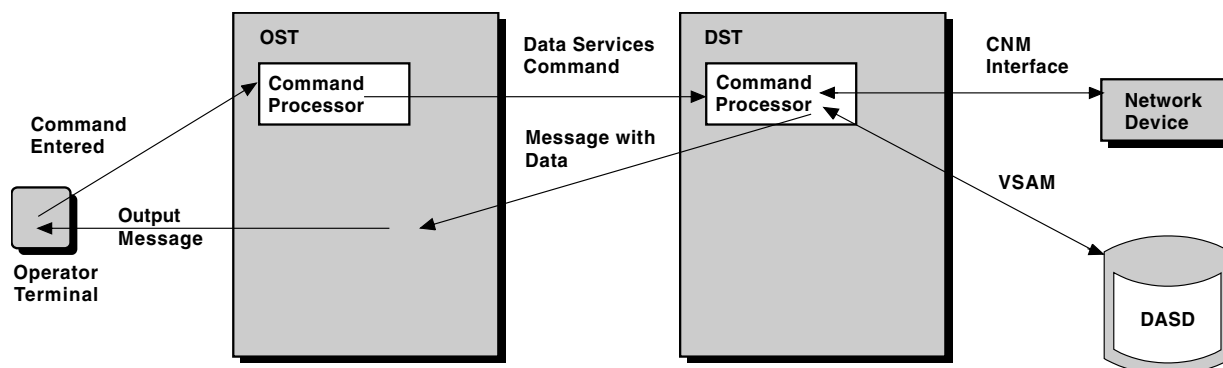

Figure 8. Program Design Example for DST Function

With long running commands, you can separate a complex function into a sequence of separate transactions. Command processors can establish a named

Customizing NetView

stack entry where an anchor address is saved. A related command processor can later retrieve this address and perform another phase of the same processing.

When naming your commands, observe the following guidelines:

- Start with a letter (alphabetic)
- Avoid special characters such as commas and colons
- Avoid NetView command names, both internal commands and those shipped in DSICMD. NetView internal command names are CSCFDST, HMSTATS, LOGNMVT, LOGRU, MESSAGE, PIPE, and VIEW.
- Avoid the following NetView prefixes:

AAU	BNT	EGV	EZL	FLB
BNH	CNM	EKG	FKB	FLC
BNI	DSI	EUY	FKV	FMG
BNJ	DUI	EXQ	FKW	FNA
BNK	DWO	EYV	FKX	IHS

Adding Optional Tasks to the NetView Program

You can write a completely new subtask in assembler language that the NetView program starts as an optional task (OPT) or subtask.

For an OPT, you must supply code for the subtask's initialization, installation exit, message, and command processing functions and termination. Because some of these elements are already provided in an existing DST, using the DST as a starting point is more practical.

Reference: For more information on OPTs and DSTs in assembler language, refer to the *Tivoli NetView for z/OS Customization: Using Assembler*.

Choosing a Language

One application program interface might be more suitable than another for your particular customization requirements. Consider the effects on performance, ease of creation, and maintenance when determining the interface to use. This section describes the languages available and lists reasons that you might choose one language over another.

Input and Output

REXX, PL/I, C, and assembler all offer functions for reading from and writing to direct access storage devices (DASD). The NetView program provides specialized disk services and VSAM data services to access network management data files. In addition, functions written in PL/I or C can invoke system allocation and access methods to read and write data. CNM interface services also provide access to data coming from devices in the network.

Reference: Refer to the *Tivoli NetView for z/OS Customization: Using PL/I and C* for information about VSAM and CNM interface services. Refer to the *Tivoli NetView for z/OS Customization: Using Assembler* for information about using DSIDKS for read access to NetView data sets or files, DSIZVSMS for VSAM I/O, and DSIZCSMS for CNM data services.

Refer to the *Tivoli NetView for z/OS Customization: Using REXX and the NetView Command List Language* for information on REXX file input and output.

Performance

Write performance-critical applications in a compiled or assembled language. Generally, compiled or assembled command procedures execute faster than interpretive (REXX and NetView command list language) command lists.

You must write NetView-driven installation exit routines in assembler, PL/I, or C. Any command processor that accesses NetView control blocks must be written in assembler. Command procedures that can be driven by terminal input or by messages and that do not need to access NetView control blocks can usually be written in REXX or in NetView command list language. Generally, command lists written in REXX perform a little better than those written in NetView command list language. See “REXX Versus the NetView Command List Language”. Additionally, the performance of REXX command lists can be improved by compiling the REXX command list.

Preloading a REXX or NetView command list (refer to the NetView online help for the LOADCL command) improves overall performance of the command list.

Reference: For details about compiling REXX command lists, refer to the *Tivoli NetView for z/OS Tuning Guide*.

For additional performance recommendations, refer to the *Tivoli NetView for z/OS Installation: Configuring Additional Components* and *Tivoli NetView for z/OS Installation: Configuring Additional Components*.

Stability

If you anticipate changes to your procedures as you gain more experience or as your operating environment changes, you might want to use command lists to implement the procedures initially. Changes are easier to make in command lists because you can incorporate the changes and test them online without having to restart the NetView program. You can translate procedures into a compiled language, if desired, when you become confident of their stability.

Testing

Testing capabilities for command lists include the ability to trace execution using either operator commands or command list statements. A remote interactive debugger (RID), which displays information to a NetView operator console, can help you in debugging PL/I and C user-written command processors and installation exits. The NetView program does not provide any specific functions to help debug assembler programs.

Speed of Implementation

Because command lists are easy to write, test, and put into production, they can be an appropriate choice in addressing immediate operational needs.

REXX Versus the NetView Command List Language

If all of your systems can run REXX, choose REXX over the NetView command list language for writing command lists. REXX is a structured language that enables you to use subroutines. REXX is the easier language to learn and provides additional functions, such as mathematical capabilities and improved string handling. REXX can read from and write to data sets with EXECIO. Additionally, the performance of REXX command lists can be improved by compiling the REXX command list.

Customizing NetView

REXX language skills can be used in environments other than the NetView program. However, REXX procedures written for the NetView program probably will not be transportable to other environments because of their function content. In multiple environments, REXX is more useful because you can transfer REXX programming skills to solve NetView problems without learning another language.

If your installation uses several operating systems, it is possible that some of them support REXX and others do not. In this case, you can create bilingual command lists that contain both REXX and NetView command list versions of your instructions. The command lists execute in REXX if REXX is available; otherwise, they process in the NetView command list language.

Reference: For details about compiling REXX command lists, refer to the *Tivoli NetView for z/OS Customization: Using REXX and the NetView Command List Language*.

Refer to the *Tivoli NetView for z/OS Customization: Using REXX and the NetView Command List Language* for more information about bilingual command lists.

Language Choices by Function

Table 5 lists additional capabilities to consider when choosing which language to use.

Table 5. Language Choices by Function

Function	REXX or NetView CLIST	PL/I or C	Assembler
Send message to NetView operator in line mode.	Yes	Yes	Yes
Interact with operator through NetView operator's screen (PAUSE/GO command).	Yes	Yes	No
Invoke NetView commands.	Yes	Yes	Difficult
Trap and process messages destined for an operator.	Yes	Yes	Difficult
Access task and common global variables.	Yes	Yes	Yes
Create and access named areas of storage.	Yes REXX; No CLIST	Yes	Yes
Interact with operator through full-screen panels.	With VIEW command	With VIEW command	Difficult
Communicate non-SPCI data over the CNM interface.	No	Yes	Yes
Access DASD or VSAM files. Note: The PIPE command provides the ability to read from disk. DSIVSAM and DSIVSMX provide access to VSAM files.	Yes	Yes	Yes
Program debugging support provided.	Yes	Yes	No
Implement NetView installation exits.	No	Most	Yes
Access NetView control blocks.	No	No	Yes

Reference: Refer to the your specific programming language guides for considerations on writing in mixed languages.

Logging

The NetView program provides several ways to log information. Table 6 lists the available features of the common logging methods.

Table 6. Features of NetView Logging Methods

Feature	Network Log	External SMF Log	External User-Defined Log	NetView Sequential Log
Access method	VSAM	VSAM	Sequential	BSAM
Device-independent	No	No	Yes	Yes
Function provided	Record all operator station activity	Service level verification and accounting	User-defined	Base service for user-defined functions
API-PL/I and C*	CNMSMSG	CNMSMSG	CNMSMSG	CNMSMSG
API-assembler	DSIWLS	DSIWLS	DSIWLS	DSIWLS
Begin recording	START	Refer to <i>Tivoli NetView for z/OS Installation: Configuring Additional Components.</i>	Refer to <i>Tivoli NetView for z/OS Installation: Configuring Additional Components.</i>	Refer to <i>Tivoli NetView for z/OS Installation: Configuring Additional Components.</i>
Browse	NetView BROWSE	No	Operating system browse	Operating system browse
Multiple log tasks	No	No	No	Yes
Variable length blocks and records	No	Yes	Yes	Yes
Primary/secondary data sets or files	Yes	System controlled	No	Yes
SWITCH, RESUME, AUTOFLIP	Yes	N/A	No	Yes
Installation exits	Many	XITXL	XITXL	XITBN, XITBO

Reference: For information about the network log, refer to the *Tivoli NetView for z/OS Automation Guide*. For information about external logging using the system management facility (SMF), a user-defined log, or sequential logging, refer to the *Tivoli NetView for z/OS Installation: Configuring Additional Components*.

Cross-Reference for Message and Environment Functions

Table 7 on page 16, Table 8 on page 17, and Table 9 on page 18 provide a cross-reference for the NetView system data, task data, and message functions. With these matrixes, you can determine whether the function you are interested in is available to the automation table, REXX, NetView command list language, or assembler. You can also determine what the name of the function is. Each matrix is alphabetized by the name of the REXX function.

Customizing NetView

Notes:

1. If you are writing assembler-language command processors, refer to the *Tivoli NetView for z/OS Customization: Using Assembler* for the BUFHDR mapping within the DSITIB mapping macro, the DSIIIFR mapping macro, and the DSIAIFRO mapping macro for exact field definitions.
2. If you are writing command lists, refer to the *Tivoli NetView for z/OS Customization: Using REXX and the NetView Command List Language* for more information about NetView command list language control variables and REXX functions.
3. If you are writing in PL/I or C language, refer to the *Tivoli NetView for z/OS Customization: Using PL/I and C* for more information about the CNMINFC, CNMINFI, and CNMGETA service routines.
4. If you are writing automation table statements, refer to the *Tivoli NetView for z/OS Automation Guide* for a description of the automation table condition items.

Table 7. Automation Variable Cross-Reference Table for System Data. The data returned is about the system. The same data is returned in every message for every task.

REXX Function	Description	Automation Table Condition Item	HLL Service Routine and Options	NetView Command List Language Control Variable	Control Block Field
ASID()	NetView address space identifier	Not available	CNMINFI ASID	&ASID	ASCBASID
CURSYS()	Current MVS system name	CURSYS	CNMINFC CURSYS	&CURSYS	CVTSNAME (MVS)
Date(USA)	Current date	Not available	CNMINFC DATE	&DATE	
DOMAIN()	Current domain name	DOMAIN	CNMINFC DOMAIN	&DOMAIN	MVTCURAN
MVSLEVEL()	Current MVS system level	MVSLEVEL	CNMINFC MVSLEVEL	&MVSLEVEL	CVTPRODN (MVS)
NETID()	VTAM network identifier	NETID	CNMINFC NETID	&NETID	ACB vectors
NETVIEW()	NetView version and release identifier	NETVIEW	CNMINFC NVVER	&NETVIEW	MVTVER
OPSYSTEM()	Operating system NetView was compiled for	OPSYSTEM	CNMINFC OPSYSTEM	&OPSYSTEM	DSISYS Compiler variable
STCKGMT() 8-byte value	Greenwich Mean Time Store Clock Value	Not available	CNMINFC CLOCK 8-byte value	&STCKGMT 8-byte value	
SUPPCHAR()	In NetView, the character that suppresses the command echo or the command's message output	Not available	CNMINFC SUPPCHAR	&SUPPCHAR	MVTSPCHR
SYSPLEX()	1-8 character name of MVS SYSPLEX where the command list is executing	SYSPLEX	CNMINFC SYSPLEX	&SYSPLEX	ECVTSPLX
TIME(option)	Current time	Not available	CNMINFC TIME	&TIME	
VTAM()	VTAM level if active	VTAM	CNMINFC VTAM	&VTAM	ACB vectors MVTACB ACBOPEN

Table 7. Automation Variable Cross-Reference Table for System Data (continued). The data returned is about the system. The same data is returned in every message for every task.

REXX Function	Description	Automation Table Condition Item	HLL Service Routine and Options	NetView Command List Language Control Variable	Control Block Field
VTCOMPID()	VTAM component identifier	VTCOMPID	CNMINFC VTCOMPID	&VTCOMPID	ACB vectors MVTACB ACBOPEN
WEEKDAYN()	Decimal number representing day of week	WEEKDAYN	CNMINFI WEEKDAYN	&WEEKDAYN	

Table 8. Automation Variable Cross-Reference Table for Task Data. The data is local to the task. The information is different for each task, but each message on that task has the same information.

REXX Function	Description	Automation Table Condition Item	HLL Service Routine and Options	NetView Command List Language Control Variable	Control Block Field
	NetView program termination indicator	NVCLOSE	CNMINFI CLOSING	Not available	MVTCLOSE
APPLID()	Application name of the current task	Not available	CNMINFC APPLID	&APPLID	TVBAPID
ARG()	Input parameters for the active command list	Not available	Not available	&PARAMSTR	
ATTENDED()	Task information	ATTENDED	CNMINFI ATTENDED	&ATTENDED	TVBSYSCN TVBAUTOO TVBDAUT
AUTCONID()	MVS console name or ID that is associated with an autotask. This MVS console can issue NetView commands to run under this autotask.	Not available	CNMINFC AUTCONID	&AUTCONID	TVBSYSCN TVBCNAME
AUTOTASK()	Autotask indicator	AUTOTASK	CNMINFI AUTOTASK	&AUTOTASK	TVBAUTOO
COMPNAME()	Component name that was active when command list invoked	Not available	Not available	&COMPNAME	
CURCONID()	MVS console name or ID used by a NetView task to issue MVS commands and receive MVS system messages	Not available	CNMINFC CURCONID	&CURCONID	TVBMCSNU TVBMCSNA
DISTAUTO()	Distributed autotask indicator	DISTAUTO	CNMINFI DISTAUTO	&DISTAUTO	TVBDAUT
HCOPY()	Hardcopy task for this task	Not available	CNMINFC HCOPY	&HCOPY	TVBHCTVB -> TVBOPID
LU()	Terminal name of the currently running task	Not available	CNMINFC LU	&LU	TVBLUNAM

Customizing NetView

Table 8. Automation Variable Cross-Reference Table for Task Data (continued). The data is local to the task. The information is different for each task, but each message on that task has the same information.

REXX Function	Description	Automation Table Condition Item	HLL Service Routine and Options	NetView Command List Language Control Variable	Control Block Field
NVCNT()	Number of domains available	Not available	Not available	&NCCFCNT	
NVID(n)	Domain ID array	Not available	Not available	&NCCFID number	
NVSTAT(name)	Domain status	Not available	Not available	&NCCFSTAT name	
OPID()	ID of currently running task	OPID	CNMINFC OPID, or CNMINFC TASKNAME	&OPID	TVBOPID
PARMCNT()	Number of input parameters to the active command list	Not available	Not available	&PARMCNT	
RC	Return code	Not available	Not available	&RETCODE	Register 15
TASK()	Type of task	TASK	CNMINFC TASK	&TASK	CBHTYPE in DSITVB
WTOREPLY	WTOR reply text	Not available	Not available	&WTOREPLY	

Table 9. Automation Variable Cross-Reference Table for Message Data. Data is different for each message or MSU. The message ID is message data.

REXX Function	Description	Automation Table Condition Item	HLL Service Routine and Options	NetView Command List Language Control Variable	Control Block Field
	1–1100 byte source object	Not available	CNMGETA MSGSRCOB	Not available	MSODATA MSOLEN
ACTIONDL()	Message deletion reason	ACTIONDL	CNMCAGA ACTIONDL	&ACTIONDL	IFRAUDLO IFRAUDTO IFRAUNVD IFRAUDFL IFRAUDF2
ACTIONMG()	Action message	ACTIONMG	CNMCAGA ACTIONMG	&ACTIONMG	IFRAUACN
AREAID()	MVS area ID	AREAID	CNMGETA AREAID	&AREAID	IFRAUWMA CPOCAREA MDBCAREA
AUTOTOKE()	MPF automation token 1–8 characters, or null	AUTOTOKE	CNMGETA AUTOTOKE	&AUTOTOKE	IFRAUTOK CPOCAUTO MDBC AUTO

Table 9. Automation Variable Cross-Reference Table for Message Data (continued). Data is different for each message or MSU. The message ID is message data.

REXX Function	Description	Automation Table Condition Item	HLL Service Routine and Options	NetView Command List Language Control Variable	Control Block Field
CART()	8-byte command and response token	CART	CNMGETA CART	&CART	CPOCCART MDBCCART
DESC()	2 bytes of MVS descriptor codes	DESC	CNMGETA DESC	&DESC	IFRAUWDS CPOCDESC MDBCDESC
GETMLINE command	Message text	TEXT	CNMGETD GETFIRST or CNMGETD GETNEXT	GETMLINE command	
GETMPRES command	4 bytes of presentation attributes This information is contained in the text buffers chained from IFRAUTBA.	LINEPRES LINEPRES only returns presentation characteristics for the first line of the message	Not available	GETMPRES command	HDRTMTPA MDBTMTA
GETMSIZE command	2-byte count of number of lines of message The value in CPOCLCNT might not reflect the actual number of buffers in the message. Therefore, assembler command processors should count the number of buffers on the IFRAUTBA chain.	Not available	Not available	GETMSIZE command	CPOCLCNT MDBCLCNT
GETMTFLG command	2 bytes of text object flags This information is contained in the text buffers chained from IFRAUTBA.	LINETFLG LINETFLG only returns object type flags for the first line of the message	Not available	GETMTFLG command	HDRTLNTY MDBTLNTY
HDRMTYPE()	NetView message type	HDRMTYPE	ORIG_MSG_TYPE ORIG_MSG_TYPE contains the message type only after CNMGETD has been issued.	&HDRMTYPE	HDRMTYPE
IFRAUGMT()	8-byte hexadecimal Store Clock value when AIFR was created	None	CNMGETA IFRAUGMT	&IFRAUGMT	IFRAUGMT

Customizing NetView

Table 9. Automation Variable Cross-Reference Table for Message Data (continued). Data is different for each message or MSU. The message ID is message data.

REXX Function	Description	Automation Table Condition Item	HLL Service Routine and Options	NetView Command List Language Control Variable	Control Block Field
IFRAUIND()	2 bytes of automation IFR indicator flags	IFRAUIND(nn)	CNMGETA IFRAUIND	&IFRAUIND	IFRAUIND
IFRAUIN3()	1 byte of indicator bits	IFRAUIN3(nn)	CNMGETA IFRAUIN3	&IFRAUIN3	IFRAUIN3
IFRAUI3X()	32-bit field of which IFRAUIN3 are the first 8 bits	IFRAUI3X	CNMCAGA IFRAUI3X	&IFRAUI3X	IFRAUI3X
IFRAUNVF	MVS Retain Flags	MVSRTAIN	CNMGETA MVSRTAIN	&MVSRTAIN	IFRAUNVF
IFRAUSDR()	Original sender of a message or MSU, whereas HDRSEND is unreliable	IFRAUSDR	CNMGETA IFRAUSDR	&IFRAUSDR	IFRAUSDR
IFRAUSRB() IFRAUSB2()	2-byte user field from the AIFR. This user field can be referenced either as bits or characters.	IFRAUSRB(nn), IFRAUSB2(n)	CNMGETA IFRAUSRB, CNMGETA IFRAUSB2	&IFRAUSRB &IFRAUSB2	IFRAUSRB
IFRAUSRC() IFRAUSC2()	16-byte user field from the AIFR. This user field can be referenced either as bits or characters.	IFRAUSRC, IFRAUSC2	CNMGETA IFRAUSRC CNMGETA IFRAUSC2	&IFRAUSRC, &IFRAUSC2	IFRAUSRC
IFRAUTA1()	6 bytes of control flags	IFRAUTA1(nn)	CNMGETA IFRAUTA1	&IFRAUTA1	IFRAUTA1
IFRAUWF1()	4 bytes of MVS specific WQE flags	IFRAUWF1(nn)	CNMGETA IFRAUWF1	&IFRAUWF1	IFRAUWF1
JOBNAME()	8-byte MVS job name	JOBNAME	CNMGETA JOBNAME	&JOBNAME	IFRAUWJA GOJGJBNM MDBGJBNM
JOBNUM()	8-byte MVS job number	JOBNUM	CNMGETA JOBNUM	&JOBNUM	IFRAUWJU CPOCOJID MDBCJID
KEY()	8-byte key associated with a message	KEY	CNMGETA KEY	&KEY	CPOCKEY MDBCKEY
LINETYPE() GETMTYPE command	Message MLWTO indicators	Not available	ORIG_LINE_TYPE ORIG_LINE_TYPE contains the line type only after CNMGETD has been issued.	&LINETYPE GETMTYPE command	HDRLNTYP IFRAUWF1(3) HDRRTYPE MDBTTYPE

Table 9. Automation Variable Cross-Reference Table for Message Data (continued). Data is different for each message or MSU. The message ID is message data.

REXX Function	Description	Automation Table Condition Item	HLL Service Routine and Options	NetView Command List Language Control Variable	Control Block Field
MCSFLAG()	2 bytes of MVS MCS flags In command lists, PL/I, and C, MCSFLAG returns a selection of eight MCSFLAG bits. In the automation table, MCSFLAG returns 16 bits that match the assembler control block field.	MCSFLAG	CNMGETA MCSFLAG	&MCSFLAG	IFRAUMCS
MSGASID()	MVS system address space identifier	Not available	CNMGETA MSGASID	&MSGASID	IFRAUASI IFRAUWAS CPOCASID MDBCASID
MSGAUTH()	Indicates whether an MVS system message was issued by an authorized program	MSGAUTH	CNMGETA MSGAUTH	&MSGAUTH	CPOCAUTH MDBCAUTH
MSGCATTR()	2 bytes of MVS message attributes flags	MSGCATTR	CNMGETA MSGCATTR	&MSGCATTR	CPOCATTR MDBCATTR
MSGCMISC()	1 byte of MVS miscellaneous routing information flags	MSGCMISC	CNMGETA MSGCMISC	&MSGCMISC	CPOCMISC MDBCmisc
MSGCMLVL()	2 bytes of MVS message-level flags	MSGCMLVL	CNMGETA MSGCMLVL	&MSGCMLVL	CPOCMLVL MDBCAUTH
MSGCMSGT()	2 bytes of message type flags	MSGCMSGT	CNMGETA MSGCMSGT	&MSGCMSGT	CPOCMSGT MDBCMSGT
MSGCNT()	Number of tokens in a message	Not available	Not available	&MSGCNT	
MSGCOJBN()	8-character originating job name	MSGCOJBN	CNMGETA MSGCOJBN	&MSGCOJBN	CPOCOJBN MDBCcojbn
MSGCPROD()	MVS system product level of the system that issued the message	MSGCPROD	CNMGETA MSGCPROD	&MSGCPROD	CPOCPROD MDBCPROD
MSGCSPLX()	1-8 character name of MVS SYSPLEX where the received message originated	MSGCSPLX	CNMGETA MSGCSPLX	&MSGCSPLX	CPOCSPLX
MSGCSYID()	Decimal system ID (for DOM)	Not available	CNMGETA MSGCSYID	&MSGCSYID	CPOCSYID MDBCsyid
MSGDOMFL()	1 byte of DOM flags	MSGDOMFL	CNMGETA MSGDOMFL	&MSGDOMFL	CPODOMFL MDBCdomfl
MSGGBGPA()	4 bytes of background presentation attributes	MSGGBGPA	CNMGETA MSGGBGPA	&MSGGBGPA	GOJGBGPA MDBGbgpa

Customizing NetView

Table 9. Automation Variable Cross-Reference Table for Message Data (continued). Data is different for each message or MSU. The message ID is message data.

REXX Function	Description	Automation Table Condition Item	HLL Service Routine and Options	NetView Command List Language Control Variable	Control Block Field
MSGGDATE()	7-character date in the form <i>yyyymmdd</i>	MSGGDATE	CNMGETA MSGGDATE	&MSGGDATE	GOJGDSTP MDBGDSTP
MSGGFGPA()	4 bytes of foreground presentation attributes	MSGGFGPA	CNMGETA MSGGFGPA	&MSGGFGPA	GOJGFGPA MDBGFGPA
MSGGMFLG()	2 bytes of MVS general message flags	MSGGMFLG	CNMGETA MSGGMFLG	&MSGGMFLG	GOJGMFLG MDBGMFLG
MSGGMID()	4-byte MVS message ID field	MSGGMID	CNMGETA MSGGMID	&MSGGMID	GOJGMID MDBGMID
MSGGSEQ()	MVS message sequence number. This sequence number, together with MSGGSYID, determine MSGGMID.	Not available	CNMGETA MSGGSEQ	&MSGGSEQ	GOJGSEQ
MSGGSYID()	System ID of the MVS system from which the message was issued	Not available	CNMGETA MSGGSYID	&MSGGSYID	GOJGSYID MDBGSYID
MSGGTIME()	11-byte time <i>hh.mm.ss.th</i> character string	MSGGTIME	CNMGETA MSGGTIME	&MSGGTIME	GOJGTIMH MDBGTIMH GOJGTIMT MDBGTIMT
MSGID()	Message ID, which is not always the first item of a message. For example, if the message is a WTOR, a REPLYID precedes the message ID.	MSGID	ORIG_PROCESS ORIG_PROCESS contains the message ID only after CNMGETD is issued.	&MSGID	
MSGORIGN()	Message domain name (or sometimes TAF session name). This always returns the domain name in AIFR buffers.	DOMAINID	ORIG_DOMAIN ORIG_DOMAIN contains the domain name only after CNMGETD has been issued.	&MSGORIGIN	HDRDOMID
MSGSRCNM()	1–17 character source name from the source object	MSGSRCNM	CNMGETA MSGSRCNM	&MSGSRCNM	MSOSUBDA MSOSBNIK MSOSBNID MSOSBNAU
MSGSTR()	Text of message after the message ID	Not available	CNMGETD GETFIRST or CNMGETD GETNEXT	&MSGSTR	
MSGTOKEN()	Numeric token associated with message	Not available	CNMGETA MSGTOKEN	&MSGTOKEN	CPOCTOKN MDBCTOKN
MSGTSTMP()	Message time stamp	Not available	CNMGETA MSGTSTMP	&MSGTSTMP	HDRTSTMP

Table 9. Automation Variable Cross-Reference Table for Message Data (continued). Data is different for each message or MSU. The message ID is message data.

REXX Function	Description	Automation Table Condition Item	HLL Service Routine and Options	NetView Command List Language Control Variable	Control Block Field
NVDELID()	NetView DOM ID	NVDELID	CNMCAGA NVDELID	&NVDELID	IFRAUGMT HDRDOMID
MSGVAR(n)	Tokens of the message In command lists, the token after the message ID is returned as the first token. In the automation table, the message ID is returned as the first token.	TOKEN	CNMGETD GETFIRST or CNMGETD GETNEXT	&1 - &31	
PARTID()	First two characters of a VSE message prefix, which, for some VSE messages, indicates the VSE partition ID	PARTID	CNMGETA PARTID	&PARTID	
PRTY()	2-byte MVS message priority	Not available	CNMGETA PRTY	&PRTY	CPOCPRTY MDBCPRTY
REPLYID()	Reply ID	Not available	CNMGETA REPLYID	&REPLYID	CPOCRPYI MDBCPRPYI CPOCRPYB MDBCPRPYB
ROUTCDE()	16 bytes of MVS routing codes (128 bits)	ROUTCDE	CNMGETA ROUTCDE	&ROUTCDE	IFRAUWRT CPOCERC MDBCERC
SESSID()	TAF session name	SESSID	CNMGETA SESSID	&SESSID	IFRAUTAF
SMSGID()	MVS system message ID for DOM correlation	Not available	CNMGETA SMSGID	&SMSGID	IFRAUWID IFRAUWWI
SYSCONID()	The MVS console name or ID that is associated with the message	SYSCONID	CNMGETA SYSCONID	&SYSCONID	IFRAUWUC IFRAUCON CPOCCNID MDBCCNID
SYSID()	8-byte MVS system name that is associated with the message	SYSID	CNMGETA SYSID	&SYSID	IFRAUWSN GOJGOSNM MDBGOSNM

Customizing PF Keys and Immediate Message Line

You can set global variables that can be searched for and placed on the PF key line on panels displayed by BROWSE, STATMON, and VIEW commands. On VIEW panels, the immediate message line is also used as the PF key line. The variable names are prefixed by (&)CNMIM and followed by the application name. Valid variables include CNMIMLBROWSE, CNMIMMBROWSE, CNMIMSTATMON, CNMIMVIEW, and CNMIMWINDOW.

Customizing NetView

For View panels, if the VIEW application has not provided a value for CNMIMDL, VIEW searches the global dictionaries (task, then common) for a variable named CNMIMxxx, where xxx is the application name provided when VIEW was invoked. If the CNMIMxxx variable is not found, VIEW searches for CNMIMVIEW in the same dictionaries. This is similar to the way keys are set for VIEW applications. Finally, if none of these variables is present, the text from message BNH257I is used.

Modifying CNMKEYS

```
----- DEFINE TEXT FOR KEY LINES -----
*
* The separator line above is required in any key definition file
* which defines "key line" texts. This separator line MUST begin
* with 9 dashes. All key definitions must precede this line, and
* all "key line" definitions must follow it.
*
* Optionally uncomment and modify the following statements, which
* assign values to the "key line" area of Statmon, Browse and View
* panels. The same rules are followed in this section as above with
* respect to commas and continuation lines. Keep the variable name
* between the delimiters, and PFKDEF will assign the rest of the line
* (including continuations) to that variable. Do not use leading
* blanks.
*
*/CNMIMSTATMON/1=HLP 2=END 3=RET 4=KYS 5=LOG 6=,
*ROL 7=BCK 8=FWD 9=SR 10=SV 11=SC 12=RTV
*/CNMIMLBROWSE/1=HLP 2=END 3=RET 4=KYS 5=RPF 6=,
*ROL 7=BCK 8=FWD 9=TOP 10=LFT 11=RGT 12=RTV
*/CNMIMMBROWSE/1=HLP 2=END 3=RET 4=KYS 5=RPF 6=,
*ROL 7=BCK 8=FWD 9=TOP 10=WIN 11=WHO 12=RTV
*/CNMIMVIEW/1=HLP 2=END 3=RET 4=KYS 5=LOG 6=,
*ROL 7=BCK 8=FWD 9=TOP 10=WIN 11=ENT 12=RTV
*/CNMIMWINDOW/1=HLP 2=RFR 3=RET 4=KYS 5=FIN 6=,
*ROL 7=BCK 8=FWD 9=TOP 10=LFT 11=RGT 12=RTV
```

Figure 9. Excerpt from CNMKEYS Sample to Set PF Keys

The PFKDEF command list (CNME1010) can assign one or more task global variables from the target file to match the key settings for applicable NetView applications. Figure 9 shows how you can set the PF keys for the Browse, Status Monitor, and View panels.

Chapter 2. Customizing the NetView Command Facility Panel

The NetView command facility panel can be customized. You can customize:

- The colors of fields on the panel
- The information that precedes the message text
- The default colors for held, action, normal, and immediate classes of messages
- The color of the command area
- How much of the panel area is set aside for held and action messages

Using a Screen Format Definition

You can use a screen format (SCRNFMT) definition to specify attributes for the command facility panel and a default value for the color of messages. To activate the screen format definition, use the NetView DEFAULTS and OVERRIDE commands. Refer to NetView online help for details on how to use DEFAULTS and OVERRIDE. A short description of each option that can be specified in a screen format definition is listed under “Screen Format Definition Statements”.

Reference: For detailed descriptions of the screen format definition statements, refer to *Tivoli NetView for z/OS Administration Reference*. CNMSCNFT is a sample screen format definition, provided in *Tivoli NetView for z/OS Installation: Configuring Additional Components*.

Notes:

1. Color and highlighting must be supported by your hardware and emulator. In addition, you must log on to NetView with a query-type logmode.
2. When you replace an active screen format definition with a new screen format definition, all definition statements are replaced. Any definition statement not specified in the new screen format definition will use the NetView-supplied value. The NetView-supplied values for each definition statement are listed in *Tivoli NetView for z/OS Administration Reference*.

For example, a screen format definition has been activated with the DEFAULTS command. Subsequently, operators activate customized screen format definitions using the OVERRIDE command. The statements not specified in an operator’s screen format definition uses the NetView-supplied value, NOT the value from the screen format definition that was activated with the DEFAULTS command.

Screen Format Definition Statements

The following screen shows the fields that you can customize on the NetView message panel.

Customizing the NCCF Panel

```
+
1  NCCF      N E T V I E W      2  NCF01 OPER1  3  04/29/96  4  11:57:30 A  5  W
8  C1 ... C16
9  |
10 - NCF01   DSI020I OPERATOR OPER1  LOGGED ON FROM TERMINAL H11L42E  USING  |
11 PROFILE (PROFSEC  ), HCL (      )
   - NCF01   DSI082I AUTOWRAP STOPPED
-----
   12 13
   ??? *** immediate messages appear here
14 |list status=tasks
+
```

Figure 10. NetView Message Panel

The following formats can be customized:

1 Title area

Use the TITLE statement in a SCRNFMT definition to customize the color of NETVIEW on the screen.

2 Domain identifier

Use the TITLEDOMID statement in a SCRNFMT definition to customize the color of the NetView domain name.

3 Operator identifier

Use the TITLEOPID statement in a SCRNFMT definition to customize the color of the operator name.

4 Current date

Use the TITLEDATE statement in a SCRNFMT definition to customize the color of the date. You can also customize the format of the date using the DEFAULTS and OVERRIDE commands.

5 Time data was last displayed

Use the TITLETIME statement in a SCRNFMT definition to customize the color of the time. You can also customize the format of the time using the DEFAULTS and OVERRIDE commands.

6 and 7 System states

Use the TITLESTAT statement in a SCRNFMT definition to customize the color of the status characters in the upper right corner of the panel.

8 COLUMNHEAD line

Use the COLUMNHEAD statement in a SCRNFMT definition to create a line at the top of the screen with labels for prefixes. This line can have up to 16 tags (C1...C16) in any order. Total length of tags, including one space between each tag, cannot exceed 78 characters. Set the tags using the SCRNFMT definition. The PREFIX and NOPREFIX statements control which tags appear. You can also choose not to have the line appear on the screen.

9 Output area

Use the HELD, ACTION, NORMAL, and NORMQMAX statements of the SCRNFMT definition.

Customizing the NCCF Panel

Note: HELD, ACTION and NORMAL statements set default colors for messages. If message color has been previously set, the default message color will not take effect. See “Message Color and Highlighting” on page 28 for more information.

The NORMQMAX statement specifies how many normal messages are queued for later display (excluding held and action messages). For example, the number of messages kept while you are working in another panel, or while the panel is locked.

When the NORMQMAX is exceeded, the NetView program automates and logs (if required) incoming messages and then discards them, without interrupting the operator. The oldest messages are discarded until the number of queued messages is half the NORMQMAX value.

When the operator returns to the command facility (or the panel is unlocked), message DSI593A indicates how many messages were discarded.

The value of NORMQMAX can range from 0 to 2147483647; the default is 3000. The minimum value allowed is 100 messages, so if you specify less than 100, it will be rounded to 100. Specifying a NORMQMAX value of 0 means an infinite queue, and is basically the same as specifying the maximum value of 2147483647.

Attention: Setting the value of NORMQMAX too high might cause out of storage conditions. Conversely, setting the value too low can prevent your operators from seeing all of their messages even when message traffic rates are low.

The NORMQMAX value also applies to hardcopy printers and to OST-NNT cross-domain sessions. Hardcopy printers can get backlogged because they are slow or because they run out of paper. An OST-NNT session can get backlogged because the message traffic over the session exceeds the send rate for that session.

10 Area for held and action messages

Use the HOLDPCNT statement in the SCRNFMT definition. The NetView program uses 10 lines of the screen for the title line, immediate message area, command area, and a warning held-message: DSI151I. Held messages are not displayed in these 10 lines. You can use HOLDPCNT to specify what percentage of the remaining lines you want to use for held messages. For example, on a 24-line screen, setting HOLDPCNT to 100% will give you 14 lines for held messages.

Specifying HOLDPCNT as 0 means that held messages will not be displayed on the screen. If HOLDPCNT is non-zero, the minimum number of lines used for held messages is two.

You can use HOLDWARN to get a warning message that held messages exist, even though they are not displayed on the screen.

Note: The NetView program will not display the control line of a held message without the data line of the message. This helps prevent operators from accidentally erasing a held message without seeing the text.

Customizing the NCCF Panel

11 Indentation

Use the INDENT and MLINDENT statements in the SCRNFMT definition.

Separator line

The LASTLINE statement of the SCRNFMT definitions changes the color of the dashed separator line between the new and old messages of the screen.

12 Command entry indicator

Use the CMDLINE statement of the SCRNFMT definition.

Lock/unlock indicator (***)

Use the LOCKIND statement in the SCRNFMT definition.

13 Immediate message area

Use the IMDAREA statement in the SCRNFMT definition.

14 Command area

Use the CMDLINE statement in the SCRNFMT definition to change the color used for the command input area. You can change the size of the command area with the INPUT command.

Message Color and Highlighting

Four color and highlighting attributes can be set for messages:

- Foreground color
- Background color
- Intensity
- Highlighting.

Note: Background color is not supported on most 3270 devices and emulators. In this case, black is used for the background color.

The color and highlighting attributes for messages can be set in several places:

- In the automation table
- For MVS system messages, in the MVS MPF table
- In installation exits
- In a screen format definition.

Of all of the options listed, the screen format definition takes the lowest precedence. The following rules of precedence apply:

- MPF table color intensity and highlighting for MVS system messages overrides the screen format definition for these attributes.
- Automation table specifications of color intensity and highlighting override the following:
 - The MPF table specified color intensity and highlighting
 - Screen format definition of color intensity and highlighting
 - DSIEX02A and DSIEX17 specification of color intensity and highlighting (these exits are driven prior to automation).
- Installation exit specifications of color intensity and highlighting override the MPF and the screen format definition for these attributes. In addition, installation exit DSIEX16 (post automation) can override the color intensity and highlighting specified in the automation table.

Each of these presentation attributes can be manipulated independently. For example, an MVS system message that had a match in the automation table with a color action would be presented in the intensity and highlighting as specified in the MPF table, but with the color as specified in the automation table.

Chapter 3. Using the VIEW Command

This chapter documents general-use programming interface and associated guidance information.

The VIEW command processor can be used to display full-screen panels from user-written programs. The VIEW command enables users to design their own panels and control the color and highlighting of panel text.

The VIEW command enables command lists or command processors written in PL/I or C to interact with an operator by means of full-screen panels. The data from the command list or PL/I or C variables can be substituted into the panels.

Creating Full-Screen Panels

To create panels for your operators, define the text and format in a data set or file. The panel source consists of a prologue, followed by text and variables that define the panel to be displayed. Figure 11 on page 30 is an example of the information in the help source file. See “General Help Fields” on page 30 for descriptions of each numbered field in the figure.

If your display consists of a sequence of lines or messages, you may find it easier to use the WINDOW command for your full-screen panel. WINDOW enables you to alter its display and to define or redirect subcommands. For more information, refer to the online help for WINDOW.

NetView provides a number of command lists that use the VIEW command to display full-screen panels. Displaying a new panel by invoking VIEW from a command list requires that you either modify an existing command list or write a new one. When you modify an IBM-supplied command list, first copy it into a user data set and change its name.

VIEW Command

```
/* *****  
/* (C) COPYRIGHT IBM CORP. 1996 1  
/* DESCRIPTION: MENU FOR NCCF INFORMATION  
/* CHANGE ACTIVITY:  
/* *****  
HELP=CNM5H000 help panel title 2  
1 CNM1OVER Cmd Facility Overview  
2 CNMKTAAF TAF Help  
3 CNMKNCSC Using NCCF Screens 3  
4 CMD='HELP NCCF COMMANDS'  
5 CNMZZZZ Field Level Help  
*** 4  
+CNMKNCCF 5 %COMMAND FACILITY HELP MENU 6  
$  
$  
\Select+ To get information about  
$  
$ %1 $Operator's overview of the command facility  
$ %2 $Using the terminal access facility (TAF) 7  
$  
$ %3 $The command facility screen  
$ %4 $Command facility commands and command lists  
$  
$ %5 $Field level help  
$  
$  
$  
+Type a number (1 through 5) and press ENTER.  
$  
$  
%  
%  
%  
%  
%  
&CNMIMDL 8  
%Action===>~&CUR 9
```

Figure 11. Example of Source for General Help Information

General Help Fields

The special characters in the source file, such as the dollar sign (\$) and the percent sign (%), are described in “Controlling Color and Highlighting of Fields” on page 35.

1 Prologue

An optional section for programmer comments. Each line of the prologue begins with /* in columns 1 and 2. Comments can only be placed in this section. If comments are displayed in the Help or Option Definitions section, a return code of 83 is sent, and the panel is not displayed. Comments that are displayed after these sections are treated as data.

2 Help

Optional definition of the panel. This field follows the prologue and is coded in the following format:

```
Column  
1 15  
HELP=helppan comment
```

Note: You can also use `HELP CMD='command_text'`. See the following description for 3.

3 Option Definitions

An optional list of selections the operator can choose. This list can contain panel names or commands. You can add an optional comment after the

panel name or command. At least one blank must separate the panel name or command from the comment. The list cannot exceed 49 entries. The list is coded in the following format:

```
Column
1 3
n panel_name or CMD='command_text' comment
```

Where *n* is the character the operator enters to call the panel or issue the command.

To produce a continuation panel, *n* is blank, as follows:

```
Column
1 3
panel_name comment
```

In this case, `panel_name` identifies the continuation panel.

4 Text Indicator

Three required asterisks separate the prologue, help, and panel definitions from the displayed panel text. These asterisks can be followed by the options listed below, which can appear in any order and must be separated by at least one blank.

- The AT1 option is attribute set 1 for color and highlighting attributes. See Table 10 on page 32 and Table 13 on page 36 for more information.
- The AT2 option is attribute set 2 for color and highlighting attributes. See Table 10 on page 32 and Table 13 on page 36 for more information.
- The XVAR option provides variables that can contain up to 31 characters, including periods.

Without this option, variables can contain only 11 characters and cannot contain periods. See Table 10 on page 32 and “Compound Symbols” on page 42 for more information on the XVAR option.

- The OPTROW=*optchar* option enables you to specify that any row (line) that begins with the character defined by *optchar* is an optional row. The maximum number of optional rows is defined as the number of rows supported by the terminal, minus 24 (which can be zero). Optional rows defined on the panel that go beyond this maximum are not displayed. Also, rows (regular or optional) that go beyond the terminal’s limit are not displayed.

For an optional row, all the characters are shifted left one position to compensate for the *optchar*, and the resulting last position (column 80) is treated as a blank.

See the WINDOW command list (CNME1505) and its View panel, CNMKWIND, as an example of how to use OPTROW.

- The WIDE option enables the entire line width to be used on terminals that support more than 80 columns. When WIDE is specified, panel variables that are the last non-blank specifications on their respective lines are substituted. The variables are not truncated until the end of the line, which is defined by the terminal.

See the WINDOW command list (CNME1505) and its View panel, CNMKWIND, as an example of how to use WIDE.

VIEW Command

Table 10. Examples of Using Text Indicator Options

Coding	Results
*** AT1	<ul style="list-style-type: none">• Attribute set 1• English• 11-character variable names, no periods

When three asterisks are followed by the AT2 option, attribute set 2 is used for color and highlighting. For example:

- *** AT2 for English
- For attribute set 1, use *** or *** AT1

For attribute set 1 and variables as long as 31 characters, use *** AT1 XVAR for English.

See “Controlling Color and Highlighting of Fields” on page 35 for more information on attribute sets 1 and 2.

5 Name

The name of the panel.

6 Heading

The text that describes the use of the panel.

7 Panel Text

Up to 24 lines of text that constitute the displayed panel. See also the OPTROW option described under “Text Indicator” on page 31.

Command list variables can appear anywhere in the panel text. See “Displaying Variables in Source Panels” on page 40 for more information.

8 Message Area

The variable &CNMIMDL displays NetView error messages on line 23 of the panel. If the application has not provided a value for CNMIMDL, VIEW searches the global dictionaries (task, then common) for a variable named CNMIMxxx, where xxx is the application name provided when VIEW was invoked. If the variable is not found, VIEW searches for CNMIMVIEW in the same dictionaries. Finally, if none of these variables is present, the text from message BNH257I is displayed. The default English text for BNH257I is “TO SEE YOUR KEY SETTINGS, ENTER 'DISPFK'”. The text of message BNH257I can be changed in the message translation table.

See “Using PF Keys and Subcommands with VIEW” on page 55 for a list of the subcommands that can be assigned to PF keys and “Customizing PF Keys and Immediate Message Line” on page 23.

9 Command Line

NetView commands are typed on the command line. In a VIEW command with the NOINPUT option specified, a command line is defined by the tilde (~) attribute symbol. The &CUR option identifies the cursor position within the command line. Only one input field and only one &CUR option is processed per panel. This option is useful for predefining a command in the input field. Otherwise, the cursor defaults in the following order:

1. The last attribute variable that specified 'UY'
2. The first tilde field, if one is present
3. The first position in the upper-left corner

Coding the VIEW Command

Code the VIEW command as follows:

VIEW**Where:****INPUT**

Specifies that input values and AID information may be returned to the procedure invoking the VIEW command. INPUT also specifies that cursor location may be received from and returned to the procedure invoking the VIEW command. When you use the VIEW command with the INPUT option, use the UNIQUE command to enforce uniqueness (only one occurrence of the command on the roll stack). See “Using the UNIQUE Command” on page 45 for more information.

name1

Specifies the name (1–8 characters) that is used internally by the NetView program. The first character must be alphabetical. A distinct name must be used for each separately rollable application. For compatibility with prior releases of the NetView program, characters 1 and 3–9 are allowed.

name2

Specifies the name (1–8 characters) of the panel to be displayed.

NOINPUT

Specifies that the VIEW command does not return any information to the procedure that invoked it. NOINPUT is the default. If the panel defines a command line, the NetView program treats input as a command. With the NOINPUT option, there is no need for your command procedure to invoke the UNIQUE command.

See Figure 11 on page 30 for the PF keys provided by the NetView program when you specify NOINPUT.

Usage Notes

- By specifying NOINPUT, you can use a command procedure to display online help panels. See “Chapter 4. Modifying and Creating Online Help Information” on page 63, for more information on how to code help panel hierarchies.
- You can use the VIEW command to display data from messages obtained through TRAP processing immediately upon receipt of the message. Updates are also possible from non-message sources on a timed basis. For more information, see “Dynamic Update Capabilities” on page 56.
- The VIEW command is intended to be used only from a command procedure. If you use the VIEW command in command lists to display a panel, minimum processing should be done between exiting the view and the end of the procedure. Operator input might be inhibited between the time the view is ended and the end of the procedure.

Return Codes from VIEW and BROWSE

Table 11 on page 34 lists and describes the return codes that can be received for the VIEW and BROWSE command. The table also provides a brief description of the action you need to take.

VIEW Command

Table 11. Return Codes from VIEW and BROWSE

Code	Meaning	Your Action
2	Trapped messages exist for this task.	Discard or process the trapped messages before calling VIEW or BROWSE.
4	<ul style="list-style-type: none"> Specified panel not found in CNMPNL1, CNMMSGF, or CNMCMDF data sets (MVS). Specified panel not found in B book within the LIBDEF search chain (VSE). Specified panel not found among files with a <i>filetype</i> of NCCFLST or a DLBL of CNMCMDF or CNMMSGF for the online help facility (VM). Possible input/output (I/O) error. 	Put panel definition in correct data set or file.
8	Panel definition format not valid; no noncomment lines found.	Correct format of panel definition.
12	You are not authorized to browse the member.	Ask your system programmer to redefine your authorization.
16	VIEW command processor invoked with parameters that are not valid. <i>Name1</i> must be 1 to 8 characters and <i>name2</i> must be a valid panel ID. Valid parameters are INPUT, NOINPUT, MSG, NOMSG.	Correct command list to use valid option.
24	Full-screen command processor is available to OST only.	Do not invoke VIEW from a non-OST.
28	Logical record length of panel not 80 bytes (VM only).	Change file to logical record length of 80 bytes.
32	Unrecoverable error resulted from macro call. Error could be that CNMMSGF or CNMCMDF has not been installed for online message or command help. For VM, error could be that the panel specified was not a file with <i>filetype</i> NCCFLST. Also, refer to message DWO050I in the NetView log.	Install CNMMSGF or CNMCMDF. For VM, change <i>filetype</i> to NCCFLST. Otherwise, call IBM for service.
36	Unrecoverable internal programming error occurred. Also, refer to message DWO050I in the NetView log.	Call IBM for service.
40	Browse panel CNMBROWS, which is used for browsing members, was not found.	Put CNMBROWS in correct data set or file.
81	Panel definition format not valid; no text indicator line found, or more than 49 option definitions found. (See Figure 11 on page 30, for more information.)	Correct format of panel definition.
83	Panel definition format not valid; comment lines in wrong place.	Correct format of panel definition.

Displaying VIEW Return Codes with SHOWCODE

The SHOWCODE command list is used by command procedures to display descriptions of the nonzero return codes returned from the VIEW command.

Code the SHOWCODE command as follows:

SHOWCODE

►—SHOWCODE *rc panelid*—◄

Where:

panelid

Specifies the name of the panel that the VIEW command attempted to display before issuing the return code. This parameter is only required for return codes 4, 8, 12, 28, 81, and 83.

rc Is the name of the variable that contains the return code for which you want to display a description.

SHOWCODE displays descriptions of the nonzero VIEW return codes as messages. Table 12 shows the return codes and their related message IDs.

Table 12. Nonzero VIEW Return Codes and Related Message IDs

Return Code	Message ID
4	CNM335I
8	CNM336I
12	CNM337I
16	CNM338I
24	CNM340I
28	CNM341I
32	CNM342I
36	CNM343I
40	CNM907I
81	CNM388I
83	CNM390I

Before issuing SHOWCODE from a command procedure, check to make sure the return code is not zero. See Figure 19 on page 58 for an example that uses SHOWCODE to display error messages from VIEW.

Controlling Color and Highlighting of Fields

You can change or add to the color and highlighting of the existing panels. Text color and highlighting in the displayed panel are controlled by attribute symbols or variables. After you code attribute symbols in the source panel, they appear as blanks in the displayed panel.

Scanning for attribute symbols or variables in a particular line occurs only if column 1 contains an attribute symbol or panel variable. Otherwise, the line is displayed as is from the panel description in the default color and without variable substitution.

Note: Color and highlighting depend on the kind of terminal you are using.

Attribute Symbols

You can specify attribute symbols on the source panel to color or highlight text. Edit the source panel and replace the blank space before the text with an attribute symbol selected from the second column of Table 13 on page 36 or Table 14 on page 36.

Variables are parsed only at the first level. Nested VIEW variables are substituted, but not parsed. Therefore, color attribute symbols that are located in nested variables are displayed as data.

An option specified in the header of a panel determines the set of attribute definitions to use for that panel. If you specify no option (**), use the original set

VIEW Command

(attribute set 1). Use attribute set 2 when you specify the option (***) AT2) on the text indicator line of the panel definition. See “View-Based Help” on page 64 for more information on the text indicator line.

Table 13. Set 1 Color and Highlighting Attributes

Attribute Set 1	Symbol	Hex Character	Intensity	Field
White	%	X'6C'	High	Text
Reversed white	}	X'D0'	High	Text
Underscored white	!	X'5A'	High	Text
White	~	X'A1'	High	Input
Turquoise	\$	X'5B'	Normal	Text
Underscored turquoise	\	X'E0'	High	Text
Blue	+	X'4E'	Normal	Text
Reversed blue	{	X'C0'	High	Text
Green	@	X'7C'	Normal	Text
Yellow	-	X'5F'	Normal	Text
Pink	:	X'6A'	Normal	Text
Red	¢	X'4A'	High	Text

Table 14. Set 2 Color and Highlighting Attributes

Attribute Set 2	Symbol	Hex Character	Intensity	Field
White	%	X'6C'	High	Text
Reversed white	}	X'D0'	High	Text
Reversed red	!	X'5A'	High	Text
White	~	X'A1'	High	Input
Turquoise	\$	X'5B'	Normal	Text
Reversed green	\	X'E0'	Normal	Text
Blue	+	X'4E'	Normal	Text
Reversed blue	{	X'C0'	Normal	Text
Green	@	X'7C'	Normal	Text
Yellow	-	X'5F'	High	Text
Reversed yellow	:	X'6A'	High	Text
Blinking red	¢	X'4A'	Normal	Text

Displaying Special Attributes

If you want to display a particular symbol that doubles as an attribute within a colored or highlighted row, place a double quotation mark (") in front of the symbol. For example, if you want the left brace (}) to appear in text, enter "{ in the source panel. If you want to display a double quotation mark ("), enter "". When you use a double quotation mark (") in the source panel, the text following the double quotation mark is shifted to the left in the displayed panel. When the same hexadecimal values for these symbols are coded as part of double-byte character text surrounded with shift-out and shift-in control characters, they are not treated as attributes.

Using the + Attribute: Be careful how you use the plus sign (+) for the color blue. If you want to assign the color blue to a variable defined by the NetView command list language, enclose the plus sign within a pair of single quotation marks as follows:

```
&COLOR = '+'
```

To assign the color blue to the REXX variable **A** so that its contents, **G**, are changed to blue, do the following:

```
A = '+G'
```

Without the pair of single quotation marks, the NetView program interprets the plus sign as a continuation character.

Using the \$ and the @ Attributes: Because the \$ character and the @ character are often used as data inside a command list or REXX variable, VIEW treats them differently when defined in a panel or in a variable. When in a panel, they are treated as attribute symbols as described in Table 13 on page 36 and Table 14 on page 36. When in a variable, they are treated as data. If the associated attributes are needed inside a variable, substitute the greater than (>) and less than (<) signs as synonyms for @ and \$ respectively. Use the respective synonym in your command list. In the following NetView command list example, the AMOUNT field displays the string \$1,000 in turquoise and the HEIGHT field displays the string @ 6 feet in green.

```
&AMOUNT = '<$1,000'  
&HEIGHT = '>@ 6 feet'
```

Here is what the same example would look like in REXX.

```
AMOUNT = '<$1,000'  
HEIGHT = '>@ 6 feet'
```

When they are not used in a variable, the less-than and the greater-than symbols are displayed as characters.

Attribute Variables

Attribute variables are assigned in the command procedure that drives the view panel. An alternative to defining attribute symbols on the panel or within the variable data is to define attribute variables that are associated with panel variables. Attribute variables describe attributes associated with panel variables and their text following on the same line. Using an attribute variable provides a wider range for attribute selection and allows you to define input fields. When you use an attribute variable, the contents of the associated panel variable are not scanned for attribute symbols.

An attribute variable name is formed by concatenating a dollar sign onto the front of the panel variable name. For example, in NetView command list language, the attribute for panel variable &V1 is defined in a variable called &\$V1.

In REXX, PL/I, and C, the ampersand (&) is not used. For a PL/I or C program, attribute variables must be set using CNMVARS in PL/I or *Cnmvars* in C.

The following is the syntax for the contents of an attribute variable:

```
►—attribute—variable—=—'—tv—tv—tv...—'—◄
```

VIEW Command

where *tv* is the *type value* pair. Multiple pairs of the same type in one attribute variable are allowed. The last pair is accepted and the previous pairs are ignored. The values for *type value* are as follows:

tv =

type value

A =

Alarm

AN

No audible alarm

AY

Audible alarm (beep) when panel is presented

Note: The alarm specification only applies to the attribute variable for the immediate message line (\$CNMIMDL).

C =

Color

CB

Blue

CD

The default device color when a color value is not specified

CG

Green

CP

Pink

CR

Red

CT

Turquoise

CW

White or neutral

CY

Yellow

F =

Field

FA

Protected; data cannot be entered on displayed panel; FA is the default

FI Unprotected; data can be entered on displayed panel

H =

Highlight

HB

Blinking

HD

The default extended highlighting when a highlighting value is not specified

HR

Reverse video

HU

Underscored

I =

Intensity

ID Dark, nondisplayable

IH High intensity

IN Normal intensity; the default when an intensity value is not specified

U =
Cursor

UN
The cursor is not placed at the beginning of this field; UN is the default.

UY
The cursor is placed at the beginning of this field. UY specifications for multiple variables cause the last variable specified to be accepted and the previous variables to be ignored.

Notes:

1. If you do not want the cursor to be associated with a particular variable, you can place the cursor in any row and column. Use the VIEWICROW and VIEWICCOL variables in the procedure that calls VIEW with the INPUT option. See “Full-Screen Input Capabilities” on page 47 for more information on the VIEWICROW and VIEWICCOL variables.
2. If you use the VIEWICROW and VIEWICCOL variables and also specify UY on an attribute variable, the cursor is positioned by the attribute variable.
3. If you do not use the VIEWICCOL and VIEWICROW variables or specify a cursor for any attribute variable on a panel, the cursor is placed at the beginning of the first input field.

Use one or more blanks to separate the *type value* pairs. The following is a NetView command list language example where &V1 is defined as a protected field with high intensity in red. &V2 is defined as a protected field in high intensity, in turquoise, with the cursor placed in the field.

```
&$V1 = 'FA IH   CR'
&$V2 = 'IN IH CT UY IH'
```

In the following REXX example, V1 is defined as an input variable (unprotected field) with no cursor. For V2, all the defaults are used.

```
$V1 = 'FI UN'
$V2 = ' '
```

Attributes defined by attribute variables or attribute symbols apply until one of the following is encountered:

- The end of the line
- The explicit placement of an attribute symbol later in the line
- A variable later in the line that has one of the following:
 - A valid attribute variable that specifies new attributes
 - No valid attribute variable, but contains one or more attribute symbols.

Constants or variables defined on a panel can become part of an input field and are updated only when you type over some portion of the input field. When you type on an input field, the entire contents of the input field are assigned to the panel variable.

The first byte of a field defined by a panel variable (the &) is used for attribute specification, and is followed by the contents of the variable. If an attribute

VIEW Command

variable corresponds to a panel variable, it takes effect at this first byte even if the panel variable is not found (and is replaced by blanks).

Note: If an attribute variable contains a syntax error and the NetView log is active, message CNM944I is written to the log.

Displaying Variables in Source Panels

When the VIEW command attempts to resolve a variable name coded on the panel definition statement, it first determines whether the variable is a NetView control variable. If the variable name is found, the appropriate NetView control variable is substituted. If the name is not found, VIEW searches for a variable of the same name that is defined by the command procedure invoking the VIEW command. For example, if the variable name &OPID is coded in the panel definition, the value for the control variable &OPID is always substituted rather than the value of a command procedure variable named OPID. If a variable name is not defined to the NetView program or in the calling command procedure, the variable coded on the panel is displayed as a string of blanks.

If the associated attribute variable is not defined, the substituted value of a variable is scanned for attribute symbols. The located attribute symbols are used in controlling color, highlighting, and data fields. If symbols are to be displayed as symbols and not used as attributes then code an associated attribute variable for the variables. This causes the symbols in the data to be treated as data instead of attribute variables.

When an attribute symbol is to be displayed as data, special rules must be followed. See “Displaying Special Attributes” on page 36 and “Attribute Variables” on page 37 for more information on these rules.

Note: If the XVAR option is not coded on the panel text indicator line, use only 1 to 11 alphanumeric characters (A–Z and 0–9) for the variable names in VIEW panel definitions. If the XVAR option is coded, variable names can be up to 31 characters long and contain periods. See “Compound Symbols” on page 42 for more information. Alphabetical characters must be in uppercase. Variable names also must conform to any other variable naming conventions set by the language invoking VIEW if the variable is to be referenced by that language. For example, variable names used in PL/I, C, and REXX must start with an alphabetical character.

For the VIEW command to find global variables, the global variables must be referenced by the command procedure prior to executing the VIEW command. Global variables are defined by &TGLOBAL, &CGLOBAL, or GLOBALV in NetView command list language, GLOBALV in REXX, CNMVARS or GLOBALV in PL/I (MVS only), or *Cnmvars* or *GLOBALV* in C (MVS only).

Reference: Refer to *Tivoli NetView for z/OS Customization: Using REXX and the NetView Command List Language* or *Tivoli NetView for z/OS Customization: Using PL/I and C* for more information about global variables.

For the VIEW command to find local or attribute variables when invoked from a high-level language program (MVS only), the variable must be set using CNMVARS in PL/I or *Cnmvars* in C.

VIEW Command

A REXX user can use VIEW to display global variables by issuing a GLOBALV DEFT (or DEFC) instruction to define the global variables before calling VIEW. However, to enable overwriting of global variables by defining them as input fields, a REXX user must do the following:

1. Issue a GLOBALV GETT (or GETC) *varname* before invoking VIEW.
2. Initialize *varname* or ensure that it does not have a null value before invoking VIEW.

If 1 and 2 are done, the global *varname* is displayed and is updated if *varname* has an attribute variable that makes it an input field. Otherwise, the REXX local *varname* is displayed and updated. When VIEW accesses a global variable this way, any REXX local variable with the same name is not affected by VIEW.

If you name a NetView control variable (for example, APPLID or OPID) on a VIEW panel, VIEW displays the control variable value and cannot access a REXX local variable with the same name. Control variables cannot be updated.

The following REXX example shows how you can use VIEW to update a global variable:

```
/* */
'GLOBALV GETT XYZ'
IF XYZ = '' THEN
DO
  XYZ = ' '
  'GLOBALV PUTT XYZ'
END
$XYZ = 'FI'
'VIEW NAME1 TESTPANL INPUT'
'GLOBALV GETT XYZ'
SAY XYZ
EXIT
```

If the length of the value assigned to the variable exceeds the length of the variable in the source panel, and if the variable is followed by alphanumeric or special characters (such as !, ¢, \, †, @, #, \$, %, ˆ, &, ", +) on the panel definition, the value is truncated. When a variable is followed by characters other than these mentioned (such as a period or a dash), the characters are overwritten.

If the value assigned to the variable contains double-byte text, all the double-byte text must be within DBCS shift-out and shift-in characters. If the panel cannot display all the double-byte text within a pair of DBCS shift-out and shift-in characters, VIEW displays all the text that fits, and displays a period (.) to indicate a truncated character.

For example, if a variable named &DBCSTEXT is defined with a value of “NetView Help Menu” in Kanji, this value may be truncated because the field on the panel is too short, because the operator has scrolled the panel to the right or left, or because an application which uses VIEW has truncated data. For instance, the NetView WINDOW command uses VIEW to handle double-byte character truncation. Here is the hexadecimal representation of the double-byte Kanji characters, showing the text length:

```
....+....1....+....2....+....3..
```

```
04945494D4545444A4A4D444A4945450
E39363530343835323F373537373438F
```

If the panel definition allows fewer than 32 characters for the value of &DBCSTEXT, or if the operator scrolls the text so that fewer than 32 characters can be displayed

VIEW Command

on the panel, VIEW displays all characters that will fit. If VIEW can only display one-half of a double-byte character, it substitutes a period (.) for the displayable part of the character, in the same way that BROWSE handles leading and trailing double-byte text truncation for netlogs. In this example, if the first two bytes were truncated, VIEW would substitute a shift-out (X'0E') for the non-displayable last half of the first double-byte character (X'4399'). If the first three bytes were truncated, VIEW would substitute a period and a shift-out character (X'4B0E') for the entire second double-byte character (X'4356').

If an operator tries to display a VIEW panel that does not have properly defined double-byte shift-out and shift-in pairs, a data stream that is not valid will be sent to the device and unpredictable results, such as the operator being logged off, will occur. Examples of DBCS definitions in which the double-byte shift-out and shift-in characters are improperly matched:

- A greater number of shift-out or shift-in characters (not paired)
- One pair split between two or more variables
- One pair split between a variable and a panel definition
- One pair split across more than one line of a panel.

Compound Symbols

A compound symbol contains at least one period and at least one other character. It cannot start with a digit or a period. If there is only one period, the period cannot be the last character.

The name begins with a STEM (part of the symbol up to and including the first period), which is followed by PARTs of the name (delimited by periods) that are constant symbols, simple symbols, or null. A constant symbol starts with a digit (0–9) or a period. A simple symbol contains no periods and does not start with digits (0–9).

VIEW starts with a compound symbol coded in a panel. Then, VIEW creates a derived variable name by replacing PARTs with their values. VIEW then requests the value of the derived variable for display in the panel.

This example is a small extract from a REXX program:

```

a=3                /* assigns '3' to the variable 'A'*/
b=4                /* '4' to 'B' */
c='Fred'           /* 'Fred' to 'C' */
a.b='Fred'         /* 'Fred' to 'A.4' */
a.fred=5           /* '5' to 'A.FRED' */
a.c='Bill'         /* 'Bill' to 'A.Fred' */
c.c=a.fred         /* '5' to 'C.Fred' */
x.a.b='Annie'      /* 'Annie' to 'X.3.4' */
d=''              /* '' to 'D' */
e='4'             /* '4' to 'E' */
x.d.e='Annie'     /* 'Annie' to 'X..4' */
say a b c a.a a.b a.c c.a a.fred x.a.4 x.d.4
/*
/* Rexx will display the following values:
/* 3 4 Fred A.3 Fred Bill C.3 5 Annie Annie*/
/* If these same variables are displayed on a View panel
/* (preceded by '&' and in upper case) and if the View panel
/* definition includes the XVAR option, View displays the following
/* values:
/* 3 4 Fred Fred 5 5 Annie

```

Figure 12. Example of a REXX Program Requesting Values of Variables for a VIEW

Implementation Maximum

All HLL and REXX variables are restricted to 31 characters when the panel text indicator has the XVAR option; otherwise, the limit is 11. NetView command list language does not support compound variables or variable names longer than 11 characters. It is important to note the differences from the way REXX displays the string and the way VIEW displays the string.

Usage Notes

- VIEW does not support mixed case symbols defined in REXX. For example, a.c in Figure 12 is displayed as 5 in VIEW, but REXX will display it as Bill.
- VIEW displays blanks for the value of the compound variable if the final value is undefined, null, or not valid.
In Figure 12 a.a, c.a, and x.d.4 are displayed as blanks in VIEW.
- VIEW does not distinguish unknown compound variable PARTs and those with null values. When a PART is null or unknown, its NAME is used in building the compound variable name. In Figure 12, VIEW searches for &X.D.4, not &X..4, and thus cannot find Annie.
- Enter ***** XVAR** in the text indicator section of your panel definition in order to use compound variables. See “Text Indicator” on page 31 for more information.

Issuing Commands from Command Procedures

When a command is issued directly from a command procedure, the procedure is suspended until that command completes. When the called command is complete and the return code is available, the procedure resumes execution. If the called command is a long-running command, it and the calling procedure form a group that is treated as a unit by the NetView ROLL command (roll group).

Note: The BGNSSESS FLSCN command is an exception because it allows a calling procedure to complete before the session begins by using the MINOR option of DSIPUSH. Refer to *Tivoli NetView for z/OS Customization: Using Assembler* for information about DSIPUSH.

VIEW Command

Grouping commands and procedures is beneficial if the intent is to build a hierarchy of related panels, using different procedures to build each one. Grouping commands and procedures is not desirable when executing unrelated commands, such as those received from an operator.

To disassociate an unrelated command from the calling procedure, use the `CMD` command. To illustrate this, assume that the variable `cmdline` contains an operator's command that was entered on your panel. You can queue the `cmdline` command asynchronously by issuing one of the following in your REXX command procedure:

```
'CMD HIGH ' cmdline  
'CMD LOW ' cmdline
```

The `HIGH` or `LOW` parameter of the `CMD` command indicates the priority at which the command should be queued.

Note: Issuing the `CMD` command with the `HIGH` parameter usually interrupts other processing, allowing the queued command to run.

For example, suppose an operator enters the `STATMON` command on the command line of your panel. By using the `CMD` command, you can queue the `STATMON` command rather than calling it directly. This allows the operator to roll back to your command procedure from `STATMON`, even though `STATMON` is not complete. Refer to *Tivoli NetView for z/OS Customization: Using Assembler* for more information about the `ROLL` function and the NetView online help for more information about the `CMD` command.

Queuing, rather than calling a command, protects your procedure from any reset condition the queued command encounters.

Creating a Rollable Component with VIEW

A NetView component is a command or command procedure that controls the terminal's screen, provides for operator entry of arbitrary NetView commands, and is capable of resuming when such commands are complete. In a command procedure, you can create a rollable component using `VIEW` to provide the necessary screen control.

If you specify the `NOINPUT` option, `VIEW` handles the operator command interface for you. If you specify the `INPUT` option on your `VIEW` command, `VIEW` returns the operator's input to your procedure in the form of named variables, one or more of which may be treated as a command.

The commands contained in these variables must be in uppercase for the NetView program. PL/I and C command procedures should verify that these command strings are in uppercase before issuing `CNMCMD`. The NetView command list language provides the `UPPER` command for translating the contents of a variable to uppercase. REXX command lists can use the `UPPER` instruction to ensure that commands are in uppercase.

Using the UPPER Command

Use the `UPPER` command to change the contents of the specified variables to uppercase.

The format of the `UPPER` command is:

UPPER**Where:***variable*

Specifies the 1- to 11-character name of the variable to be translated to uppercase. The comma in the repeat separator indicates that you can optionally specify more than one variable name on an UPPER command.

Example:

```
UPPER CMDLINE
CMD HIGH &CMDLINE
```

Usage Notes:

1. Do not specify the leading ampersand (&) in front of the variable name.
2. If you specify more than one variable, all variables are translated, even if one of the variables has an error condition (not found or the length is not valid).
3. The UPPER command is provided in the NetView command list language only. A similar function is available to REXX command lists with the REXX UPPER instruction.
4. The UPPER command should not be concatenated with other commands in a command string.

Return Codes: The return codes for this command are as follows:

- | | |
|----|---|
| 0 | Successful completion of all specified variables |
| 4 | At least one variable not found, or at least one variable is not valid |
| 8 | At least one variable length not within range |
| 12 | At least one variable not found and at least one other variable length not within range |
| 16 | Not invoked from a command procedure |
| 20 | No variables specified |

Using the UNIQUE Command

With the UNIQUE command you can search the roll stack for a component that has a subcomponent with the same member name (for command lists and REXX) or module name (for PL/I and C) as the issuing command procedure. If such a component is found, the UNIQUE command allows only one of the two components to remain on the roll stack, either the issuing component or the older component.

The format of the UNIQUE command is:

UNIQUE

VIEW Command



Where:

CANCEL

Specifies to reset (CANCEL) the roll group containing the matching element on the roll stack as the currently running component. CANCEL is the default. (The issuing component remains on the roll stack.)

PROMOTE

Specifies to position (PROMOTE) the roll group containing the matching element on the roll stack as the currently running component.

Usage Notes

1. The UNIQUE command is valid only when issued from a command list.
2. The NetView program allows an operator to start many copies of the same command processor. You might not want more than one copy, as when creating a NetView component. By using DSIPOP or DSIPUSH with the PROMOTE option, assembler programmers guarantee the uniqueness of long-running commands. Using the UNIQUE command guarantees uniqueness in a command procedure.
3. Issuing UNIQUE from your procedure has no effect (and gives a 0 return code) if the current copy of the procedure is the only one active. An *active* long-running command or procedure is one that is in any stage of its processing but is not yet complete. Active procedures include procedures that are suspended (blocked) by some other long-running command. If another copy of the same procedure exists under the same task, the UNIQUE command affects the entire roll group that includes that copy.
4. When you use UNIQUE with the CANCEL option (the default format), the calling procedure is temporarily suspended while the older copy is given control with a reset condition. The NetView program suppresses the cancellation messages normally issued when a procedure is reset. When the canceled copy of the procedure and any others in its group complete, the issuing copy resumes with the next line after the UNIQUE command. The return code is set to 4.
5. Using the UNIQUE command with the PROMOTE option moves the previous copy of the calling procedure and its roll group to the top of the roll stack, ready to resume when the copy issuing UNIQUE completes. The return code is set to 4. The procedure invoking UNIQUE should exit at this point to allow the promoted procedure to regain control. An exit code -5 is used to let the caller know that it can now regain control.
6. When you use UNIQUE in NetView command list language, code a suppression character (&SUPPCHAR) to suppress unwanted command echoes that occur when the command has an error. Code SIGNAL ON HALT in your REXX procedures to suppress the REXX cancellation message. The HALT subroutine should return a -5 return code. When you code SIGNAL ON ERROR in your REXX procedures, a return code of 4 signals the error label.
7. No special processing is required for the ROLL command. It is issued in the same way as other NetView commands. To be consistent with other NetView applications, set PF6 and PF18 to issue the ROLL command.

8. Parameter synonyms are supported.
9. Parameter authorization restrictions are not appropriate for the UNIQUE command.
10. Upon cancellation of a component, REXX, PL/I, and C command procedures can perform a cleanup.

Return Codes: The return codes for this command are as follows:

- | | |
|----|---|
| 0 | The calling procedure is unique. |
| 4 | A matching procedure was found. Action successful. |
| 12 | Environment is not valid (not called from a procedure). |
| 16 | Syntax error, argument is not valid. |

Full-Screen Input Capabilities

The VIEW command can receive the following values from the calling procedure:

- The cursor row position
- The cursor column position.

You specify this information with the INPUT keyword and by coding VIEWICROW and VIEWICCOL in the calling procedure. When the panel is displayed, the cursor is positioned at the location specified by VIEWICROW and VIEWICCOL. If you used an attribute variable to associate the cursor with a variable, that overrides cursor positioning by VIEWICROW and VIEWICCOL. Table 15 on page 48 describes these two variables.

The VIEW command allows the following to be returned to the invoking procedure:

- The contents of multiple input-capable variables on a panel
- The attention identifier (AID) information
- The cursor location
- The number of panel rows put out by the VIEW command
- The number of panel columns put out by the VIEW command.

You specify this information with the INPUT keyword and by coding an attribute variable with the FI *type value* pair.

When you use the INPUT option, an input field is available only if you defined an attribute variable specifying FI. (See “Attribute Variables” on page 37 for information on the *type value* pair.)

When the panel is displayed, it contains the variable values that you can modify by typing over them. The modified variables are returned to the invoking procedure when you press the AID key. Table 16 on page 49 describes the AID key and the variables that are set on return to the calling command procedure.

VIEW Command

Table 15. Variables Specified in the Calling Command Procedure

REXX, PL/I, and C	NetView Command List Language	Description
VIEWICCOL	&VIEWICCOL	The cursor location (column) set by the command procedure that calls VIEW. Use this variable with VIEWICROW to position the cursor anyplace on the panel. An acceptable value is a positive or negative integer less than or equal to the number of columns on the panel. A positive integer positions the cursor relative to the left side; a negative integer, relative to the right side. If you specify an integer greater than the number of columns on the panel, the cursor is placed at the beginning of the first input field. See Figure 13.
VIEWICROW	&VIEWICROW	The cursor location (row) set by the command procedure that calls VIEW. Use this variable with VIEWICCOL to position the cursor anyplace on the panel. An acceptable value is a positive or negative integer less than or equal to the number of rows on the panel. A positive integer positions the cursor relative to the top; a negative integer, relative to the bottom. If you specify an integer greater than the number of rows on the panel, the cursor is placed at the beginning of the first input field. See Figure 13.

Assume a panel 80 x 24, and the calling procedure specifies:

```
VIEWICCOL = 2  
VIEWICROW = 2
```

The cursor is placed in the second column from the left, second row from the top.

```
VIEWICCOL = -2  
VIEWICROW = -2
```

The cursor is placed in the second column from the right, second row from the bottom.

```
VIEWICCOL = 82  
VIEWICROW = 22
```

The cursor is placed at the beginning of the first input field because one of the variables specifies a value that is greater than the panel size.

Figure 13. VIEWICCOL and VIEWICROW Examples

Table 16. Variables Set on Return to Calling Command Procedure

REXX, PL/I, and C	NetView Command List Language	Description
VIEWAID	&VIEWAID	The AID key used to enter the input.
VIEWCURCOL	&VIEWCURCOL	The cursor location (column) when the AID key is pressed.
VIEWCURROW	&VIEWCURROW	The cursor location (row) when the AID key is pressed.
VIEWCOLS	&VIEWCOLS	The number of columns output by the VIEW command. The default number will be 80 if neither WIDE nor OPTROW is coded on the panel text indicator line, or if the terminal only supports 80 columns. Otherwise, VIEWCOLS is set to the number of columns supported by the terminal. See "Chapter 4. Modifying and Creating Online Help Information" on page 63 for more information.
VIEWROWS	&VIEWROWS	The number of rows (lines) of the given panel that were output by the VIEW command, which is determined by the number of regular data lines in the source panel, the number of optional data lines in the source panel, and the number of rows available on the output terminal. See "Chapter 4. Modifying and Creating Online Help Information" on page 63 for more information.

The contents of the VIEWAID variable are defined as PF1 through PF24, PA1, PA2, PA3, or the ENTER key.

If you press PA1, PA2, or PA3, only the AID (VIEWAID) information is returned to the invoking procedure. The cursor row, column locations, and any input fields defined on a panel are not returned.

Note: If you press the ATTN key on an SNA terminal, VIEW with INPUT/NOINPUT ends.

Figures 14 through 18 illustrate source panels using VIEW with the INPUT option to create a rollable component. Figure 14 and Figure 15 on page 50 show the source panels containing input-capable variables to be replaced. These panels use attributes from attribute set 2 (see Table 14 on page 36).

VIEW Command

```

/*****
/* FIRST PANEL DISPLAYED */
/*****
*** AT2
+PANEL1
$ X=====X
$
$
$ % PPPPPP AAAAAA NN NN EEEEEEE LL 111 $
$ % PP PP AA AA NNN NN EE LL 11 11 $
$ % PPPPPPP AAAAAAAA NN NN NN EEEEEEE LL 11 $
$ % PP AA AA NN NNN EE LL 11 $
$ % PP AA AA NN NN EEEEEEE LLLLLLLL 11111111$
$
$-----$
$ INPUT VARIABLE 1 = &VARIN1 $
$ INPUT VARIABLE 2 = &VARIN2 $
$
$ You entered: &VAROUT1
$ You also entered: &VAROUT2
$ X=====X
$
$Enter a command on the command line OR...
$Enter NEXT or press PF8 to view the next panel.
$
%Action==> &COMMAND %
$
$ PF6/PF18= Roll PF2= End
$ PF6/PF18= Roll PF8=Next

```

Figure 14. Source for First Panel with Input-Capable Variables and Command Line

```

/*****
/* SECOND PANEL DISPLAYED */
/*****
*** AT2
+PANEL2
$ X=====X
$
$
$ % PPPPPP AAAAAA NN NN EEEEEEE LL 22222222 $
$ % PP PP AA AA NNN NN EE LL 22 $
$ % PPPPPPP AAAAAAAA NN NN NN EEEEEEE LL 22222222 $
$ % PP AA AA NN NNN EE LL 22 $
$ % PP AA AA NN NN EEEEEEE LLLLLLLL 22222222 $
$
$-----$
$
$
$
$
$ X=====X
$
$Enter a command on the command line OR...
$Enter BACK or press PF7 to view the previous panel.
$
%Action==> &COMMAND %
$
$ PF6/PF18= Roll PF2= End
$ PF6/PF18= Roll PF7= Previous

```

Figure 15. Source for Second Panel with Command Line Only

Figure 16 on page 51 is an example of a REXX command list that invokes VIEW with the INPUT option to display PANEL1. The command list assigns initial values to the VARIN1 and VARIN2 input-capable variables in the source panel. The

command list also returns the AID information and command line input to the caller.

```

/*****
/* EXAMPLE: NETVIEW COMPONENT USING THE VIEW COMMAND */
/*****
SIGNAL ON HALT
/*****
/* RESUME OLD COPY IF ONE EXISTS */
/*****
'UNIQUE PROMOTE'
if rc = 4 then EXIT -5 /* -5 will cancel caller if it exists */
SIGNAL ON ERROR /* any nonzero rc other than as a result of the */
/* UNIQUE command is an error */
/*****
/* set up VAR1 and VAR2 as input capable fields */
/*****
$VARIN1 = 'FI IN CR HB UN'
$VARIN2 = 'FI IH CG HR UN'
/*****
/* set up COMMAND as an input command line using an attribute */
/* variable. Also define the cursor to stop at this field. */
/*****
$COMMAND = 'FI UY'
VARIN1 = 'INITIALIZE 1'
VARIN2 = 'INITIALIZE 2'
Do forever
COMMAND = '00'X /* COMMAND = nullchar (this clears */
/* the command line and provides */
/* for insert capability) */

'VIEW USERAPPL PANEL1 INPUT'
UPPER COMMAND
VAROUT1 = VARIN1
VAROUT2 = VARIN2
SELECT
  When viewaid = 'PF2' then exit /* Quit if PF2 */
  When viewaid = 'PF6' then CMD HIGH ROLL /* Roll if PF6 */
  When viewaid = 'PF8' then call PANEL2 /* Next panel if PF8 */
  When viewaid = 'ENTER' then
    SELECT
      when command = NEXT then call PANEL2
    /*****
    /* Assume any other input given on command line is */

```

Figure 16. Example of a REXX Command List that Drives a Rollable Component (Part 1 of 2)

VIEW Command

```

/*          to be issued to NCCF          */
/*****
when COMMAND ^= ' ' then
    DO
        'CMD HIGH' COMMAND
    END
    otherwise nop
END
OTHERWISE nop
End /* select */
End /* Do forever */
PANEL2:
Do forever
    COMMAND = '00'X /* COMMAND = nullchar (this clears */
                    /* the command line and provides */
                    /* for insert capability) */

'VIEW USERAPPL PANEL2 INPUT'
UPPER COMMAND
SELECT
    When viewaid = 'PF2' then exit /* Quit if PF2 */
    When viewaid = 'PF7' then return /* Previous panel PF7*/
    When viewaid = 'PF6' then 'CMD HIGH ROLL ' /* Roll if PF6 */
    When viewaid = 'ENTER' then
        SELECT
            When COMMAND = 'BACK' then return
            /*****
            /*          Assume any other input given on command line is */
            /*          to be issued to NCCF          */
            /*****
        when COMMAND ^= ' ' then
            DO
                'CMD HIGH' COMMAND
            END
            otherwise nop
        END
    OTHERWISE nop
End /* select */
End /* Do forever */
RETURN
ERROR:
EXIT -1 /* -1 means "FATAL ERROR IN NESTED PROCEDURE" */
HALT:
EXIT -5 /* -5 means "CANCEL REQUESTED" */

```

Figure 16. Example of a REXX Command List that Drives a Rollable Component (Part 2 of 2)

Figure 17 on page 53 is an example of the first panel created from this command list. See Figure 14 on page 50 for the source for this panel. The variables VARIN1 and VARIN2 are replaced with the actual values INITIALIZE 1 and INITIALIZE 2, respectively. The attribute specification is defined by \$VARIN1 and \$VARIN2 (see “Attribute Variables” on page 37 for more information).

The following attributes are for VARIN1 where the length of the input field continues until the next attribute symbol is encountered. In this case, the attribute symbol is %.

VARIN1 attributes are as follows:

- Input, tab (unprotected)
- Normal intensity
- Red
- Blinking
- No cursor position.

VIEW Command

The following attributes are for VARIN2 where the length of the input field continues until the end of the line.

VARIN2 attributes are:

- Input, tab (unprotected)
- High intensity
- Green
- Reverse video
- No cursor position.

COMMAND attributes are:

- Input, tab (unprotected)
- Position the cursor at the beginning of this field.

```
PANEL1
X=====X
      P P P P P P P P   A A A A A A   N N   N N   E E E E E E E E   L L           1 1 1
      P P   P P   A A   A A   N N N   N N   E E           L L           1 1   1 1
      P P P P P P P P   A A A A A A A A   N N   N N   N N   E E E E E E E E   L L           1 1
      P P           A A   A A   N N   N N   E E           L L           1 1
      P P           A A   A A   N N   N N   E E E E E E E E   L L L L L L L L   1 1 1 1 1 1 1 1
-----X
      INPUT VARIABLE 1 = INITIALIZE 1
      INPUT VARIABLE 2 = INITIALIZE 2

      You entered:
      You also entered:
X=====X

Enter a command on the command line OR...
Enter NEXT or press PF8 to view the next panel.

Action==>  _
              PF6/PF18= Ro11          PF2= End
              PF8=Next
```

Figure 17. Display Panel of Component with Variables Replaced by REXX Command List

Figure 18 on page 54 shows a second display panel from the command list. See Figure 15 on page 50 for the source for this panel.

VIEW Command

```
PANEL2
X=====X
      P P P P P P P P   A A A A A A   N N   N N   E E E E E E E E   L L       2 2 2 2 2 2 2 2
      P P   P P   A A   A A   N N N   N N   E E           L L           2 2
      P P P P P P P P   A A A A A A A A   N N   N N   N N   E E E E E E E E   L L       2 2 2 2 2 2 2 2
      P P   A A   A A   N N   N N   E E           L L           2 2
      P P       A A   A A   N N   N N   E E E E E E E E   L L L L L L L L   2 2 2 2 2 2 2 2
X=====X

Enter a command on the command line OR...
Enter BACK or press PF7 to view the previous panel.

Action==> _
           PF6/PF18= Roll           PF2= End
           PF7= Previous
```

Figure 18. Display Panel of Component

Returning Command Line Input

When you specify NOINPUT for the NetView program to start processing at the command line, you should define a tilde (~) on the panel to be displayed.

The tilde definition defines an input field that is returned to the NetView program as a command. An &CUR coded after the tilde on the same line determines where the cursor is positioned.

The &CUR is useful for predefining a partial command. For example:

```
~ V NET,ACT,ID=&CUR
```

coded on a panel displays:

```
V NET,ACT,ID=_
```

with the remaining ID to be completed by the operator.

If more than one is defined on the panel, the last &CUR is processed and previous ones are ignored. If more than one tilde (~) is defined on the panel, the first tilde is processed and any subsequent ones are changed to a percent (%) sign.

If you specify INPUT for the NetView program, code the command line as you would code any other input-capable field. Do not use the &CUR and tilde definitions. The procedure that displays the panel issues the commands. See "Issuing Commands from Command Procedures" on page 43, for information on issuing CMD HIGH.

Using PF Keys and Subcommands with VIEW

PF keys and VIEW subcommands are treated differently with the two view options, INPUT and NOINPUT. The following two sections explain the differences.

Using PF Keys and Subcommands with the NOINPUT Option

When you use VIEW with the NOINPUT option, you can define your PF keys using the PFKDEF command. The values you assign can be NetView commands, or VIEW subcommands. The following is a list of the VIEW subcommands; some have the same name as similar NetView commands:

Help Displays the help panel previously coded:

HELP=helppan

End Exits to the originating component.

Return

Returns to the last panel from which a selection was made.

Top Returns to the first page of a multipage panel.

Bottom

Goes to the last page of a multipage panel.

Backward

Returns to the previous page of a multipage panel.

In addition to assigning the Backward subcommand to a PF key, you can also enter the following command on the command line to scroll backward a specific number of pages:

B *n* Scrolls backwards *n* number of pages or panels.

Forward

Goes to the next page of a multipage panel.

In addition to assigning the Forward subcommand to a PF key, you can also enter the following command on the command line to scroll forward a specific number of pages:

F *n* Scrolls forward *n* number of pages or panels.

Entry Point

Shows the panel that the operator first saw upon entry to help.

Reference: Refer to the PFKDEF command in the *Tivoli NetView for z/OS Administration Reference* for more information.

Using PF Keys and Subcommands with the INPUT Option

When you use VIEW with the INPUT option, you can use settable PF keys defined using the PFKDEF command or you can interpret PF keys in your command list. You need to code the panel definition and parameters differently depending on the option you select.

Using Settable PF Keys

To use settable PF keys with VIEW, complete each of the following steps:

1. In the panel definition, create a variable named CNMIMDL that has no attribute-variable (\$CNMIMDL) which makes it an input field. Define the immediate message line by putting &CNMIMDL in column 1 of the line. Do not put anything else on that line.

VIEW Command

If the VIEW application has not provided a value for CNMIMDL, VIEW searches the global dictionaries (task, then common) for a variable named CNMIMxxx, where xxx is the application name provided when VIEW was invoked. If this variable is not found, VIEW searches for CNMIMVIEW in the same dictionaries. This is similar to the way keys are set for VIEW applications. Finally, if none of these variables are present, the text from message BNH257I is used.

2. In the panel definition, create a variable named CNMCMDL that does have an attribute-variable (\$CNMCMDL) which makes it an input field. CNMCMDL defines the command area.
3. Optionally, create another variable named CNMDIMD to define a default immediate message. This message is displayed by NetView whenever the CNMIMDL message has been displayed and there are no other immediate messages. If you do not create CNMDIMD, NetView defaults it the same way it defaults CNMIMDL.

All these variables support attribute (\$) variables.

For example, you might call VIEW with an error message in CNMIMDL and a default message in CNMDIMD, with \$CNMIMDL set to CR and \$CNMDIMD set to CG. The error message will be displayed in red, but if the user presses a RETRIEVE key or delay-type key, for example, the red message is replaced by the default message, in green.

The REXX command WINDOW is a good example of coding VIEW panels to set PF keys. Enter BROWSE WINDOW to see the REXX source for this command.

Notes:

1. VIEW-input applications that do steps 1 and 2 always have their VIEWAID variable set to ENTER after invoking VIEW, because other keys are converted as if the user typed the command text and pressed ENTER.
2. The &CNMIMDL variable is nulled out when control is returned to the command list from VIEW, if VIEW detected that the immediate message area was overwritten by NetView after the VIEW panel was output (for example, by an immediate command entered by the operator).
3. The special variables CNMIMDL and CNMDIMD are supported in VIEW-noinput as well as VIEW-input. CNMCMDL only has special meaning in VIEW-input.

Dynamic Update Capabilities

The VIEW command enables you to dynamically update the contents of the panel being displayed. The updates can be controlled by:

- **The calling procedure**

When VIEW detects that a message TRAP is satisfied, VIEW returns control to the calling procedure to allow the update of local variable values displayed on the VIEW panel. VIEW refreshes the display with the new values when control is returned to VIEW using the RESUME command.

- **Any automation or procedure running on the same task**

If the variables named on your VIEW panel are not defined by the calling procedure, VIEW attempts to read values from task global variables. For more information, refer to the online help for the GLOBALV command and the PIPE

VAR stage. Values of task global variables can be updated by any procedure called on the same task (same operator ID) and VIEW immediately refreshes the display when the procedure completes.

- **Any procedure in NetView**

If the variables named on your VIEW panel are not defined by the calling procedure and do not exist as task global variables, VIEW attempts to read values from common global variables. For more information, refer to the online help for the GLOBALV command and the PIPE VAR stage. Any procedure in the NetView program can update the values of common global variables; however, VIEW refreshes the display only when an event (such as receipt of a message) occurs at the task that started VIEW.

While a panel is displayed, automation from timers, messages, or alerts can drive command procedures that update some of the variables substituted into the displayed panel. Any processing under the OST where the panel is displayed causes a dynamic update of the panel with new values for any variables that have changed.

To make information on the panel easier to see, and make it easier to enter information on the panel while a panel is dynamically updated, assign values to attribute variables for all variables on the panel that can be changed dynamically. This enables VIEW to send only the updated information to the screen without rewriting the entire screen for each update.

When VIEW detects certain changes to common, task, and local variables or their associated attribute variables, VIEW must rewrite the entire panel.

If the entire screen is redisplayed, changes typed by the operator on the screen being redisplayed are lost. Following is a list of these changes:

- The attribute variable for a given data variable has changed to indicate that a field has been changed from protected to unprotected or vice-versa.
- An attribute variable for a given data variable now has a valid value. It either did not exist or it had a value that is not valid.
- An attribute variable for a given data variable now has no value or a value that is not valid. It previously had a valid value.
- The value for a data variable has changed, and a valid attribute variable is not associated with the data variable.

To continue processing of the VIEW command after variables used by the displayed panel are updated, use the RESUME command.

Sample of Panel Updating

The following figures show the dynamic updates of the contents of a panel.

Figure 19 on page 58 is an example of a command list called RESDYN which is shipped as part of sample CNMS1101. RESDYN uses the RESOURCE command output as data to be displayed in a panel using the VIEW command. The displayed data is updated on a time interval that you specify when calling the command list. The default time interval is 10 seconds.

VIEW Command

```
/* ----- Dynamic Resource Display (option 12) ----- */
/* A demonstration of using VIEW and TRAP to dynamically update a */
/* full screen display. We use the SPILL option of pipe's KEEP */
/* (new for V5) to create a message after the specified refresh */
/* interval. This message is TRAPPED, causing VIEW to return */
/* control to this procedure WITHOUT removing the displayed panel. */
/* The 'RESUME', below is a REINVOICATION of the original VIEW!!! */
/* Note that the first call to "fillVars" passes an extra little */
/* bit of pipe to the subroutine. The purpose is to get the first */
/* word of the second data line (STC name) for the panel. */
/* ----- */
resdyn:
  interval = 10          /* refresh at 10 second intervals          */
  privMsgID = 'CNMRESDYN' /* special purpose "msgid" for trapping          */
  getSTC = '% STC:|DROP 1|TAKE 1|EDIT W1|VAR JBN'
  Call fillVars getSTC   /* set local variables with data from RESOURCE */
  'TRAP AND SUPPRESS MESSAGES' privMsgID /* TRAP our special message */
  'PIPE VAR privMsgID | KEEP RESDYN' interval 'SPILL' /* make msg later */
  'VIEW RESDYN CNMSRESP'
  DO WHILE (rc = 2)      /* RC indicates "message trapped"?          */
    'MSGREAD'           /* just getting msg off trap queue          */
    CALL fillVars
    'PIPE VAR privMsgID | KEEP RESDYN' interval 'SPILL' /* make msg later */
    'RESUME'           /* Invoke VIEW, previously suspended          */
    /* NOTE: RC, at this point, is RC from VIEW, which was resumed. */
  END
  'pipe hole | keep resdyn' /* empty safe created above          */

return
/* ----- Obtain data for RESDYN display (option 12) ----- */
/* Notice that the stem variable "out." is in our local variable */
/* dictionary. VIEW could always read these value; new for V5R1, */
/* we will have an opportunity to update them while VIEW is active. */
/* ----- */
fillVars:
  ARG xtraStg           /* use extra first time only          */
  'PIPE (NAME RESDYN END %)',
  | NETVIEW RESOURCE',
  | SEPARATE DATA',
  | STC: FANOUT',
  | EDIT SKIPTO /=/ 2.* STRIPL 1 ',
  | COLOR WHITE',
  | $STEM OUT.',
  xtraStg
  TM = date() time()
  $TM = 'CB HR'
return
```

Figure 19. Example of a REXX Command List to Update a Panel

Figure 20 is an example of the output from the RESDYN command list.

```

CNMSRESP NetView Resource Utilization      5 Sep 2001 14:46:39

TOTAL CPU PERCENTAGE      = 100.00
T510EENV CPU PERCENTAGE  = 33.62
T510EENV CPU TIME USED   = 41,175.45 SEC.
REAL STORAGE IN USE      = 23360K
PRIVATE ALLOCATED < 16M  = 752K
PRIVATE ALLOCATED > 16M  = 23180K
PRIVATE REGION < 16M     = 7144K
PRIVATE REGION > 16M     = 65536K

TO SEE YOUR KEY SETTINGS, ENTER 'DISPFK'
CMD ==>

```

Figure 20. RESDYN Command List Output Example

Figure 21 is the source panel text that displays the previous panel (Figure 20).

VIEW manages the PF keys and the command line without the intervention of the RESDYN command list.

```

*** AT2 XVAR SFD
+CNMSRESP NetView Resource Utilization +   &TM
$
$
$      TOTAL CPU PERCENTAGE      = &OUT.1
$      &JBN      CPU PERCENTAGE  = &OUT.2
$      &JBN      CPU TIME USED   = &OUT.3
$      REAL STORAGE IN USE      = &OUT.4
$      PRIVATE ALLOCATED < 16M  = &OUT.5
$      PRIVATE ALLOCATED > 16M  = &OUT.6
$      PRIVATE REGION < 16M     = &OUT.7
$      PRIVATE REGION > 16M     = &OUT.8
$
$
$
$
$
$
$
$
$      $Display is updated approximately every 10 seconds.
&CNMIMDL
%CMD==>~&CUR

```

Figure 21. CNMSRESP Source Panel Text

Changing Colors in Browse

The template shown in Figure 22 on page 60 is used when browsing members of a partitioned data set. Note the various applications of the color attributes shown in Table 13 on page 36 and Table 14 on page 36. The characters %, \$, ~, and + each assign a specific color to the screen area immediately following their positions. To change a color area on the screen, you need only change the color attribute. You can only change existing attribute fields; changing any other field can result in errors when browsing.

Chapter 4. Modifying and Creating Online Help Information

The NetView program contains a help facility, which has two types of help information.

The first type of help is *view-based help*, which is displayed by using the VIEW command. The second type is *window-based help*, which is displayed by using the WINDOW command.

This chapter explains how you can add, delete, or modify help information and is arranged in the sequence you use to accomplish this. The sequence follows:

1. Locate the help source file.
2. Copy and change the source file.
3. Store the copy.
4. Display the help to test your changes.

Locating Help Source Files

Source files define the panel contents that are displayed.

Help information is contained in a separate file and is shipped as a member in a partitioned data set (PDS). English help source files are stored in the NETVIEW.V5R1M0.CNMPNL1 data set.

Notes:

1. Japanese help source files are stored in the NETVIEW.V5R1M0.SCNMPNL2 data set.
2. Copies of the command and message help are stored on the Web Server. If you customize the command and message help in NetView data set members, you may want to make the same changes to the Web Server files.

Verify that your organization has not changed the library name.

Before you create a new help source, try to locate an existing online help that is similar to the one you want to create. Generally, when you have a help source file displayed, the file name is in the top left corner.

For command help information, you can locate the source file you want to change by browsing the HELPMAP. Window-based help files are prefixed with the < character. See “HELMAP Facility” on page 68 for more information on the HELPMAP. Help information for groups of messages is stored as members of the PDS, one member for each group. The member name is determined by truncating the message ID prior to the last numeric digit. For example, help for messages DSI001I and DSI002I are stored in member DSI00. Help for message EKGV68001I is stored in member EKGV6800.

If a message or command help panel is currently being displayed, you can use the SHOWDATA command to locate the source file. Figure 23 on page 64 displays the information returned after entering SHOWDATA on the command line.

Note: In Figure 23 on page 64, the following are true:

1. The panel is located in member EUYCLIST of the CNMPNL1 data set.

Modifying Online Help

- The !+! listed in the response from the SHOWDATA command is generated by special processing from the help search procedure and can be ignored.

```
CNMPNL1.EUYCLIST      HELP PIPE STAGES      LINE 1 OF 41
<      Read from a PDS member . . . . . <
$STEM  Read and set stemmed variables and attributes. $1
$VAR   Read and set variables and attributes . . . . $2
BETWEEN Divide message streams into sections . . . . B2
CASEI  Compare character strings . . . . . C3
CHANGE Replace string occurrences . . . . . C12
CHOP   Truncate lines after string . . . . . C14
COLLECT Create multiline messages . . . . . C31
CONSOLE Display messages in a pipeline . . . . . C32
CORRCMD Process a command in a pipeline . . . . . C33
CORRWAIT Allow asynchronous messages in a pipeline . . C34
CONSOLE Display messages in a pipeline . . . . . C59
DROP   Drop messages from a pipe . . . . . D34
ENVDATA Output environment data . . . . . E15
EXPOSE Exposes messages in a pipe . . . . . E23
FANIN  Read from multiple input streams . . . . . F1
HELDMSG Place held messages in a pipeline . . . . . H18
HOLE   Discard messages or judge correlation . . . . H34
INTERPRT Build stages from data . . . . . I10
JOINCONT Joins consecutive messages . . . . . J1
CNMPNL1.EUYCLIST, for !+! PIPE,STAGES PIPE,COMMANDS STAGES
CMD==> showdata
```

Figure 23. Example of Using the SHOWDATA Command to Locate Help Source Files

View-Based Help

The source file contents include the text of the displayed panel and the definition statements associated with the panel. A definition statement includes:

- A prologue
- The help panel name
- The continuation panel name
- A list of associated help panels

To view the source file for a View-based help panel, enter:

```
BROWSE CNMPNL1.panelid
```

Where *panelid* is the name that is displayed in the upper-left corner of the source for the help. For additional information, see “Creating Full-Screen Panels” on page 29.

Window-Based Help

Figure 24 on page 65 is an example of the source format of the Window-based help information. Descriptions of each numbered field follow the figure.

```

*** EUYRET 5697-B82 (C) Copyright IBM Corp. 1997 1
* All Rights Reserved.
* CHANGE ACTIVITY:
*
===== REPEAT RFIND 2
REPEAT (BROWSE) 3

:H2. Syntax 4

>>--REPEAT--<<
:H2. IBM-Defined Synonyms

+-----+-----+
| Command or Operand | Synonym |
+-----+-----+
| REPEAT | R or RFIND |
+-----+-----+

:H2. Purpose of Command

The REPEAT command reissues the last FIND command while you are browsing
the network log or a member of a partitioned data set. Since this
command is sensitive to the current position of the cursor, it is
normally entered using a PF key.

By repeatedly pressing the PF key set to REPEAT, you can find successive
occurrences of a specified character string. After the first occurrence
of a character string has been found, the REPEAT key will find the next
occurrence. After the last occurrence of a character string has been
found, the REPEAT key can be used to continue the search, wrapping
around from the bottom line to the top line (or from the top line to the
bottom line if the FIND command included the PREV parameter.)
===== RETURN RET
2
RETURN (BROWSE, HELP, HELPDESK, NCCF, NLDM, NPDA, STATMON, TARA, VIEW)

:H2. Syntax

>>--RETURN--<<
:H2. IBM-Defined Synonyms

+-----+-----+
| Command or Operand | Synonym |
+-----+-----+
| RETURN | RET (for BROWSE, HELP, HELPDESK, |
| | STATMON, and VIEW) |
| | R (for NLDM, NPDA, and TARA) |
+-----+-----+

Note: The command facility has no synonym for RETURN.

:H2. Purpose of Command

The RETURN command returns you to the previous component or the last
selection panel that you used.

You should not issue this command from a command list.
:H2. Restrictions
:
:

```

Figure 24. Example of Source for Message and Command Help Information

1 Prologue

An optional section for programmer comments.

Modifying Online Help

2 Message or Command

The message or command to which the text applies. If the help information is for a command that can be used in more than one component, the command name is prefixed with the component name. Command names must be preceded by 14 equal (=) signs and a blank space.

3 Message or Command Help Title

The title of this help source file.

4 Tags

Information can be presented in different ways. These can include:

- `:H2.` is used to highlight command names.
- `:XMP.` and `:EXMP.` are used to surround examples.
- `:IF DTYPE=`PANEL followed by `:ENDIF` marks a section that is shown when HELP presents a full-screen display.
- `:IF DTYPE=`MSGS followed by `:ENDIF` marks a section that is shown when HELP presents a line mode display. This occurs when HELP is called at an autotask or when full-screen displays are otherwise unsupported.
- `:LINK.` is used to move from one topic to another. The `:LINK.` tag must be in uppercase and begin in column one; it precedes the display line to which it pertains. This line becomes a tab stop and is highlighted by WINDOW. If more than one line of text is to be highlighted for linking, the `:LINK.` tag must precede each line. See the example coding in Figure 25 on page 67.

The operator makes a selection by placing the cursor on the line or by issuing a FIND command that selects the line. Optionally, you can designate a keyword that the operator can type to issue the command. The keyword is enclosed in parentheses immediately following the `:LINK.` tag.

- `:CMD.` is used to precede a command that can be executed immediately when that line is selected. The command line can contain variable text (for example, `HELP msgno`) that the operator can overlay with specific data, then press the ENTER key to execute the command. The `:CMD.` tag has an end tag, `:ECMD.`, and must follow the line of command text. Both `:CMD.`, and its end tag must be in uppercase and begin in column 1.

A portion of EUYSLIST is shown in Figure 25 on page 67 to show how the `:IF DTYPE` and `:LINK.` statements are coded.

```

:
:
===== COLLECT
COLLECT (NLDM,PIPE)

COLLECT is associated with more than one NetView component.

:IF DTYPE=ANEL
Select    To Get Information About
:LINK.(A)HELP NLDM COLLECT
  A      NLDM COLLECT Use Session Monitor to collect response time data
:LINK.(B)HELP PIPE COLLECT
  B      PIPE COLLECT A Pipe stage which collects messages in a pipe
:LINK.(C)HELP PIPE STEM
  C      If you use the COLLECT command following a STEM command, see the
:LINK.(C)HELP PIPE STEM
         description of the COLLECT operand of the STEM command. Enter C.
:ENDIF
:IF DTYPE=MSG
Enter HELP NLDM COLLECT for help on the Session Monitor COLLECT command
Enter HELP PIPE COLLECT for help on the COLLECT pipe stage
:ENDIF
:
:

```

Figure 25. Example of Using :IF DTYPE= and :LINK.

Copying and Changing Help Source Files

Before you create a new help source file, try to locate an existing online help file that is similar to the one you want to create. See “Locating Help Source Files” on page 63.

If you find a comparable panel, copy it using a screen editor. Change the panel by typing over the existing text or by adding text. If you cannot find a similar online help file, use a screen editor to build a new one.

If you want to modify or create a help source file while the NetView program is running, define your panel data set without secondary extents. Otherwise, a panel can be filed in a new extent, requiring that you close and restart the NetView program to use the panel.

The conventions for structuring a new panel are the same as those for modifying an existing panel. All help source files must have a fixed-length blocked record format and a logical record length of 80 bytes (RECFM=FB, LRECL=80), unless you are using a fully qualified data set name listed in the HELPMAP. See “HELPMAP Facility” on page 68 for more information. Null characters are also counted within this 80-byte record. In addition, you might need to change a command list or another panel that is affected by your new panel.

You can customize the HELPDESK to include topics specific to your installation. NetView provides a template file, CNMHDSKU, that can be edited to create these topics.

1. Add the new topics to CNMHDSKU.
2. Add the new topic identifiers to the table of contents in file CNMHDSK0.

Note: If you want to customize any of the existing HELPDESK files (CNMHDSK1–CNMHDSK9), put the information in a separate file and use the %INCLUDE statement. Otherwise, that information will need to be added each release.

Modifying Online Help

After creating or modifying a help file, store it in a data set concatenated to DDNAME CNMPNL1. As an alternative, you can also modify the panel with an SMP USERMOD. See “Storing Help Source Files” for more information.

Storing Help Source Files

Ensure your panel names do not use the same prefixes used by NetView-supplied panel names.

Store all help source files that you create or modify. Two methods for storing help files follow:

- Concatenate the user partitioned data set that contains the modified help file to the CNMPNL1 DD statement in the NetView startup procedure **before** the data set NETVIEW.V5R1M0.CNMPNL1. If the Support Center modifies the panel, those changes will not be added to your help file.
- Include your modified help file into a System Modification Program (SMP) USERMOD and apply the USERMOD so that SMP stores the modified panel in NETVIEW.V5R1M0.CNMPNL1. SMP automatically notifies you of any future changes that the Support Center makes to the panel you modified. For more information on how to use an SMP USERMOD, refer to the *System Modification Program* library.

Notes:

1. The default data set for the Japanese version of the product is NETVIEW.V5R1M0.SCNMPNL2.
2. English help source files are stored in the NETVIEW.V5R1M0.CNMPNL1 data set. Verify that your organization has not changed the library name.

HELPMAP Facility

The HELP command scans the HELPMAP for the required command help member name using the arguments as search targets. HELP uses the arguments in the following manner:

- With no arguments
When you enter HELP without supplying any arguments, you get component-level HELP for the component you are in.
If the target arguments are not found in the table, HELP searches for a pair of parentheses () and uses the associated panel name.
- With one argument
When one argument is supplied, HELP attempts to resolve the argument as a command synonym, if possible.
- With two or three arguments
When two or three arguments are supplied, the search target is constructed by concatenating the arguments with commas. For example:
ONE,TWO,THREE

HELPMAPU is a specific HELPMAP for user-defined help files created for commands. A %INCLUDE statement contained in HELPMAP embeds HELPMAPU that provides the mapping for those help files created by the user.

Note: Do not map user-defined help files to HELPMAP. These changes interfere when IBM applies maintenance to HELPMAP.

Modifying Online Help

A portion of CNMHHELPF is shown in Figure 26 to show how the help names are listed. Those that are prefixed with the < character are window-based help files; others are view-based help files.

```
*****
* 5697-B82 (C) COPYRIGHT IBM CORPORATION 1997 *
* ALL RIGHTS RESERVED. *
* NAME(CNMHELPF) SAMPLE(CNMHELPF) RELATED-TO(HELPMAP) *
* DESCRIPTION: NETVIEW HELP MAPPINGS FOR *
* FULL BASE FUNCTION. *
* *
*****
CNMKNEEW ()
<EUYACQ ACQ
<EUYACT ACT
<EUYACION ACTION NPDA,ACTION
.
.
.
<EUYMENU MENU NLDM,MENU NPDA,MENU TARA,MENU
<EUYMEAGE MESSAGE
<EUYMONIT MONIT STATMON,MONIT
<EUYMOOFF MONOFF STATMON,MONOFF
<EUYMONON MONON STATMON,MONON
<EUYMRENT MRECENT MR NPDA,MRECENT NPDA,MR
<EUYMSG MSG
<EUYSLIST MVS
<EUYMVS NCCF,MVS COMMAND,MVS
<EUYSTART MVS,START
CNMKNCCF NCCF DSINCCF
.
.
.
```

Figure 26. Example of the HELPMAP

You can add fully qualified data set names within single quotes to the HELPMAP. See the following example as a guide:

```
<'USER.CNMPNL1(MYCMDHLP)' MYCOMAND
```

Displaying New Help Panels

After you have created a new help panel, use the HELP command to view the new panel, and any associated commands or panels, to ensure that they display properly.

Chapter 5. Customizing Session Monitor Sense Descriptions

NetView provides help for VTAM sense codes through the session monitor SENSE command. You can request help for either 2-byte or 4-byte sense codes. The information used to present explanations for the sense codes is stored as a set of members in the DSIPARM data set. You can customize these members or include additional members to include help for sense codes that have additional meaning for a specific application.

Session Monitor Sense Codes

The session monitor sense code descriptions are stored as DSIPARM members named CNMB nnn , where nnn is the first three hexadecimal digits of the 2-byte and 4-byte sense codes described in the member. For example, help for sense codes 08B2 and 08B60001 is stored in DSIPARM member CNMB08B. The CNMB08B member shipped with the NetView product is shown in Figure 27 on page 72

The general conventions are:

- The descriptions are first grouped by the leftmost two bytes of the sense code, using a separator of \$\$\$KEY $xxxx$??? where $xxxx$ is the hexadecimal value of the leftmost two bytes. The description of the 2-byte sense code $xxxx$ (or 4-byte sense code $xxxx0000$) follows this separator.
- Extended sense code descriptions, identified by the rightmost two bytes of a 4-byte sense code, are grouped using a separator of \$ $nnnn$ where $nnnn$ is the hexadecimal value of the rightmost two bytes. The extended description follows this separator.
- Text descriptions must be contained in columns 1–57 of the DSIPARM member. This text is not DBCS-enabled.

Note: Any modifications you make to existing DSIPARM CNMB xxx members may be replaced by maintenance or another release of the NetView product. You can update the comments at the beginning of the DSIPARM CNMB xxx members to document your changes, and store any members you create or modify in a data set concatenated before the NetView-supplied DSIPARM data set. This helps keep your modifications from being overlaid by subsequent maintenance or product changes.

Customizing Session Monitor Sense Descriptions

```
*****
* 5697-B82 (C) COPYRIGHT IBM CORP. 1986, 1997 *
* DESCRIPTION: SAMPLE -- SENSE CODES *
* CNMB08B CHANGED ACTIVITY: *
* CHANGE CODE DATE DESCRIPTION *
* ----- *
*****
$$$KEY 08B2????
Data transmission failure: the data transmission between
an application program in an SNA MS entry point and an
application program in a subentry point was incomplete,
causing abnormal termination of the function. Bytes 2
and 3 following the sense code contain sense code
specific information.
$0000
No specific code applies.
$0001
A time-out has occurred while waiting for transmission of
data between the two application programs. For example,
a service processor has timed out while waiting to
receive data from the main processor.
$0002
A time-out has occurred while waiting for transmission of
data between two applications.
$$$KEY 08B5????
Network Node Server Not Required: Sent by an APPN end
node control point to a network node control point (1) to
deactivate CP-CP sessions with the NNCP, or (2) to reject
a CP-CP session BIND from the NNCP. The end node no
longer requires network node services from the receiver.
Note: This sense data value is carried within the X'35'
control vector on an UNBIND(Type = X'01') for case (1)
above, or on an UNBIND(Type = X'FE') for case (2).
VTAM Hint: A possible cause of this error is that the
Network Node Server for the CP-CP session attempt is not
in the Network Node Server List.
$$$KEY 08B6????
CP-CP Sessions Not Supported: Sent by a network node
control point to reject a CP-CP session BIND from another
APPN control point; support for CP-CP sessions on that TG
was removed since the time when the TG was first
activated.
Note: This sense data value is carried within the X'35'
control vector on an UNBIND(Type = X'01'). Bytes 2 and
3 following the sense code contain sense-code-specific
information.
$0000
No specific code applies.
$0001
During link activation on a switched link, it
was discovered that the partner node does not
support CP-CP sessions on this TG.
```

Figure 27. CNMB08B Sense Code Help

Examples

Following are some examples of adding and modifying sense code description members in DSIPARM:

- To add additional help for sense code 08B2 or 08B20000, change the NetView-supplied help as follows:

Customizing Session Monitor Sense Descriptions

```
$$$KEY 08B2????
```

Data transmission failure: the data transmission between an application program in an SNA MS entry point and an application program in a subentry point was incomplete, causing abnormal termination of the function. Bytes 2 and 3 following the sense code contain sense code specific information.

The SNA MS entry points currently defined are SYSTEM1 and SYSTEM2.

Note the two lines of help information added for this installation-specific sense code.

- To add help for a new sense code 08B3 or 08B30000, add the following information immediately after the NetView-supplied information for sense code 08B2. For example:

```
$$$KEY 08B3????
```

This sense code is generated by application XYZ when a failure occurs between components of the application.

Note the two lines of help information added for this installation-specific sense code.

- To add help for a new sense code 08B60002, add the following information immediately after the NetView-supplied information for sense code 08B60001. For example:

```
$0002
```

During link activation on a switched link, it was discovered that the partner node does not permit sessions with this partner.

Note the three lines of help information added for this installation-specific sense code.

- To add help for a new sense code 08C1xxxx, create a new member in DSIPARM named CNMB08C, and include the following statements:

```
$$$KEY 08C1????
```

This sense code is generated by application ABC when a failure occurs in a component of the application.

The third and fourth bytes of the sense code identify the failing component ID.

Note the four lines of help information added for this installation-specific sense code.

Customizing Session Monitor Sense Descriptions

Chapter 6. Customizing Hardware Monitor Displayed Data

This chapter describes how to modify the presentation of generic and nongeneric alerts. In prior releases of NetView, Recommended Action panels, Event Detail panels, and alert messages were stored at the host. Each nongeneric alert had a unique set of panels and messages. Many of these remain in the current release of NetView. With generic alerts, generic alert code points are used to dynamically build the hardware monitor panels.

This chapter describes how to do the following:

- Modify the text of nongeneric Recommended Action and Event Detail panels
- Modify nongeneric alert messages
- Overlay recommended action numbers from a generic alert
- Control the use of color and highlighting for hardware monitor panels
- Include user-defined errors, such as creating and modifying generic code points or adding resource types to the hardware monitor

Note: Color maps for hardware monitor help panels and command description panels are available only in prior releases of NetView.

If your panels or alert messages have been translated into a language that requires double-byte characters, take care to preserve the integrity of the double-byte character set (DBCS) strings.

Modifying Hardware Monitor Nongeneric Panels

Recommended Action panels and Event Detail panels are defined for event conditions that are not based on generic alert records. If several event conditions use the same Recommended Action panel or Event Detail panel, the panel is physically defined under a single name, the *actual panel name*. Any other name under which the actual panel can be displayed is the *panel alias*. Determining whether the panel name is an actual name or an alias is the first step in modifying panel text.

You can make changes to the panel text, and these changes are reflected in all its aliases. You can also make changes to a panel alias, resulting in the creation of a new panel under the former alias name.

Determining a Panel Name

To determine a panel name and whether it is a panel name or an alias, you must know the event associated with the text you want to change and then identify a resource for which the event is logged. Use the following steps as a guide to help you determine the type of name:

1. To identify a resource, display the Alerts-Static, Alerts-History, or Most Recent Events panel.
2. Enter sel# C, where sel# is the selection number on the panel of the event associated with the text you want to change. Message BNJ962I displays a 5-digit code associated with the event. If message BNJ378I is displayed, the event is generic and stored panels are not associated with the event.

If you receive a product ID and alert ID rather than a 5-digit code, the associated record is a generic alert. Generic alerts do not have unique prestored

Customizing Hardware Monitor Displayed Data

panels in the hardware monitor. See “Using NMVT Support for User-Written Programming” on page 90 for more information on generic alerts.

3. Examine the 5-digit code, *xxxxyy*, that NetView returns. The variables are described as follows:
 - xxx* Is the NetView-designated product code, or block ID, for the resource.
 - yy* Is an individual panel identifier.
4. Determine which panel contains the text you want to change, as follows:
 - For a Recommended Action panel, the panel name (or panel alias) is *BNLxxxxyy*, where *xxx* and *yy* are the codes you identified in step 3.
 - For an Event Detail panel, the panel name (or panel alias) is *BNKxxxxyy*, where *xxx* and *yy* are the codes you identified in step 3.
 - Determine whether *BNLxxxxyy* or *BNKxxxxyy* is an actual or alias panel name:
 - Use an editor, such as ISPF/PDF to examine the directory listing of panel names. This listing is in the NetView-provided partitioned data set (PDS) named *NETVIEW.V5R1M0.BNJPNL1*. The word *alias* is displayed to the right of panel names that are aliases.
 - See the appropriate section of this book for the action you want to perform: “Changing Panel Text” on page 78, “Changing from Alias to Actual” on page 78, “Deleting an Actual or Alias” on page 79, or “Adding an Actual or Alias” on page 79.

Figure 28 is an example of a *BNJBLKID* table.

Customizing Hardware Monitor Displayed Data

```

TITLE 'BNJBLKID: LIST OF ALIAS TABLES BY BLOCK ID'
BNJBLKID CSECT
        EJECT
        DS 0F
NUMENT  DC AL4((TABEND-TABSTART)/LENG) NO. OF ENTRIES
TABSTART EQU *
        DC CL3'FED'
        DC CL3'FEE'
        DC CL3'FEF'
        DC CL3'FE1'
        DC CL3'FE2'
        DC CL3'FE3'
        DC CL3'FE4'
        DC CL3'FFD'
        DC CL3'FFE'
        DC CL3'FFF'
        DC CL3'FF2'
        DC CL3'FF5'
        DC CL3'FF6'
        DC CL3'FF7'
        DC CL3'FF8'
        DC CL3'FF9'
        DC CL3'GA1'
        DC CL3'GB1'
        DC CL3'GC1'
        DC CL3'003'
        DC CL3'005'
        DC CL3'017'
        DC CL3'02D'
        DC CL3'02F'
        DC CL3'021'
        DC CL3'022'
        DC CL3'023'
        DC CL3'03E'
        DC CL3'036'
        DC CL3'037'
        DC CL3'038'
        DC CL3'04A'
        DC CL3'04B'
        DC CL3'04C'
        DC CL3'04D'
        DC CL3'04E'
        DC CL3'04F'
        DC CL3'043'
        DC CL3'044'
        DC CL3'047'
        DC CL3'048'
        DC CL3'049'
        DC CL3'057'
        DC CL3'47C'
TABEND  EQU *
LENG    EQU 3                      ENTRY BYTE LENGTH
        END BNJBLKID

```

Figure 28. Sample BNJBLKID Table

Figure 29 on page 78 is an example of a BNJALxxx table.

Customizing Hardware Monitor Displayed Data

```

TITLE 'BNJAL036: ALIAS TABLE FOR BLOCKID 036'
BNJAL036  CSECT
          EJECT
          DS 0F
NUMENT   DC AL4((TABEND-TABSTART)/LENG)  NO. OF PAIRS
*        REAL NAME      ALIAS NAME
TABSTART EQU *
DC CL8'BNI03609',CL8'BNI0366D'
DC CL8'BNI03608',CL8'BNI0366C'
DC CL8'BNI03607',CL8'BNI0366B'
DC CL8'BNI03606',CL8'BNI0366A'
DC CL8'BNI03605',CL8'BNI03669'
DC CL8'BNI03605',CL8'BNI03671'
DC CL8'BNI03605',CL8'BNI0360D'
DC CL8'BNI03604',CL8'BNI03668'
DC CL8'BNI03604',CL8'BNI03670'
DC CL8'BNI03604',CL8'BNI0360C'
DC CL8'BNI03603',CL8'BNI03667'
DC CL8'BNI03602',CL8'BNI03666'
DC CL8'BNI03601',CL8'BNI03665'
DC CL8'BNI0360B',CL8'BNI0366F'
DC CL8'BNI0360A',CL8'BNI0366E'
DC CL8'BNK03609',CL8'BNK0366D'
DC CL8'BNK03608',CL8'BNK0366C'
DC CL8'BNK03607',CL8'BNK0366B'
DC CL8'BNK03606',CL8'BNK0366A'
DC CL8'BNK03605',CL8'BNK03669'
DC CL8'BNK03604',CL8'BNK03668'
DC CL8'BNK03603',CL8'BNK03667'
DC CL8'BNK03602',CL8'BNK03666'
DC CL8'BNK03601',CL8'BNK03665'
DC CL8'BNK0360D',CL8'BNK03671'
DC CL8'BNK0360C',CL8'BNK03670'
DC CL8'BNK0360B',CL8'BNK0366F'
DC CL8'BNK0360A',CL8'BNK0366E'
TABEND   EQU *
LENG     EQU 16                      ENTRY PAIR BYTE LENGTH
END BNJAL036

```

Figure 29. Sample BNJALxxx Table

Changing Panel Text

If BNIxxxxyy or BNKxxxxyy is an actual panel name (not an alias), follow these steps to change the panel wording. BNIxxxxyy panels must contain exactly 14 noncomment lines; BNKxxxxyy panels must contain exactly seven noncomment lines. Comment lines contain an asterisk (*) in column 1.

1. Use an editor, such as ISPF/PDF, to edit the PDS member containing the panel. The PDS name is NETVIEW.V5R1M0.BNJPNL1 (unless it is changed during installation), and the member name is the same as the panel name.
2. Save the changed member.

The changes apply to all event conditions that use the panel or any of its aliases.

Changing from Alias to Actual

If you want to make a panel that now appears under an alias into an actual panel, follow these steps:

1. Use an editor, such as ISPF/PDF, to edit the PDS member containing the panel alias. The PDS name is NETVIEW.V5R1M0.BNJPNL1 (unless it is changed during installation), and the alias member name is the same as the panel name.
2. Save the changed member. TSO converts the panel alias into an actual panel.

Customizing Hardware Monitor Displayed Data

A new actual panel is created under the name that was formerly the alias.

Reference: For more information about MVS utilities and JCL, refer to the *MVS/Extended Architecture* library.

Deleting an Actual or Alias

To delete an actual or alias panel name, do one of the following:

- Delete the PDS member containing the actual or alias panel name. The PDS name is NETVIEW.V5R1M0.BNJPNL1 (unless it is changed during installation), and the member name is the same as the panel name.
- Use the utility IEHPROGM. For example, to delete aliases BNK04B2E and BNK04B2F using this utility, you could code the following:

```
//DELMEBR2 JOB  MSGLEVEL=(1,1)
//STEP1  EXEC  PGM=IEHPROGM
//SYSPRINT DD  SYSOUT=A
//DS1 DD  VOL=SER=vsnum,DISP=SHR,UNIT=device_type
//SYSIN DD *
SCRATCH VOL=device_type=vsnum,DSNAME=panel_dsname,
        MEMBER=BNK04B2E
//STEP2  EXEC  PGM=IEHPROGM
//SYSPRINT DD  SYSOUT=A
//DS1 DD  VOL=SER=vsnum,DISP=SHR,UNIT=device_type
//SYSIN DD *
SCRATCH VOL=device_type=vsnum,DSNAME=panel_dsname,
        MEMBER=BNK04B2F
/*
```

In this example, *device_type* is the device type, *vsnum* is the volume serial number on which the data set resides, and *panel_dsname* is the name of the data set containing the panels.

Reference: For more information on MVS utilities and JCL, refer to the *MVS/Extended Architecture* library.

Adding an Actual or Alias

If you want BNK*xxxxyy* or BNK*xxxxyy* to be a new (or replacement) panel name or alias, follow these steps:

- Enter a new panel using an editor, such as ISPF/PDF, and copy an existing panel that is similar to the desired panel. Then, change the copied panel.
- Add the new panel name or an alias, using the utility IEBUPDTE.

For example, to add BNK04B2E as an alias of BNK04B2A using IEBUPDTE, code the following:

Customizing Hardware Monitor Displayed Data

```
//PANELS JOB MSGLEVEL=1,MSGCLASS=A
//UPDATE1 EXEC PGM=IEBUPDTE,PARM=NEW
//SYSPRINT DD SYSOUT=A
//SYSUT2 DD DSN=panel_dsname,DISP=SHR,UNIT=device_type,
//          VOL=SER=vsnum
//SYSIN DD *
./ ADD NAME=BNK04B2A
  DETAIL DESCRIPTION: THE ERROR ANALYSIS MICROCODE
  HAS DETECTED AN INVALID ERROR LOG ENTRY.
```

```
          LOG ENTRY 0-3          4-7          8-11
*****
          .
          .
          .
*
*
*
*****LAST LINE OF PDS MEMBER*****
./ ALIAS NAME=BNK04B2E
/*
```

In this sample, *panel_dsname* is the name of the data set where the panel is stored, and *vsnum* is the volume serial number on which the data set resides. Although the sample defines only one new alias, up to 15 aliases are valid.

Reference: For more information on MVS utilities and JCL, refer to the *MVS/Extended Architecture* library.

Nongeneric Alert Messages

To change the Event Description: Probable Cause text of any selection on an Alerts-Static, Alerts-History, Alerts-Dynamic, Event Detail, or Most Recent Events panel that is not associated with generic alerts, follow these steps:

1. Determine the event of the associated text and identify a resource against which the event is logged.
2. For the resource identified in Step 1, display the Alerts-Static, Alerts-History, Alerts-Dynamic, Event Detail, or Most Recent Events panel.
3. Enter sel# C, where sel# is the selection number of the event associated with the text you want to change. Message BNJ962I displays a 5-digit code associated with the event. If message BNJ378I is displayed, the event is generic. If you receive a product ID and an alert ID rather than a 5-digit code, the associated record is a generic alert. Generic alerts do not have unique prestored Event Description: Probable Cause text messages in the hardware monitor. See "Using NMVT Support for User-Written Programming" on page 90 for more information on generic alerts.
4. Examine the following 5-digit code, *xxxxy*, that NetView returns.
xxx Is the NetView-designated product code, or block ID, for the resource
yy Is an individual hexadecimal panel identifier
5. Use an editor such as ISPF/PDF to retrieve and edit the CSECT that contains the text you want to change. The name of the CSECT is BNJVM*xxx* (PDS member in NETVIEW.V5R1.BNJSRC1), where *xxx* is the block ID you identified in Step 4.

Customizing Hardware Monitor Displayed Data

6. Locate the message text within BNJVMxxx. The message number for this text is the decimal equivalent of *yy*, where *yy* is the hexadecimal identifier you determined in Step 4.
7. Change the assembler language macro DSIMDS.

Reference: For the syntax of DSIMDS, refer to *Tivoli NetView for z/OS Customization: Using Assembler* for the text you want to change.

8. Save the changed CSECT.
9. Reassemble the CSECT, and link-edit the CSECT into the load module of the same name.

Using the ACTION Command List

You can use the ACTION command list to get more information on a recommended action that is displayed in the hardware monitor. See “Chapter 4. Modifying and Creating Online Help Information” on page 63 for information on how to modify the Action Help panels displayed by the ACTION command list. *Dnnn*, *Ennn*, and *Innn* are recommended action numbers found on the Recommended Action panels. *Rnnn* numbers are actions found on the resolution action panel. The following describes what the ACTION command list displays for recommended action numbers:

ACTION Dnnn

Displays a NetView-provided, detailed description of a recommended action.

ACTION Ennn

Displays a description of a recommended action, created by your system programmer, for a user-defined generic alert action.

ACTION Innn

Displays a description of a recommended action created for a NetView-provided generic alert action.

ACTION Rnnn

Displays a description of an actual action created for a NetView-provided resolution action.

Overlaying Recommended Action Numbers

Because details of a particular generic alert Recommended Action can vary depending on the sending product, Action Help panels cannot be provided for all possible generic actions. Therefore, on NetView Action Help panels built for generic alerts, each recommended action is preceded by an I-number (Tivoli-supplied action) or an E-number (user-supplied action).

On Recommended Action panels of the hardware monitor, each recommended action is identified with a special action number. Figure 30 shows a sample Recommended Action panel with three recommended actions (D225, D001, and D238).

Customizing Hardware Monitor Displayed Data

```

NETVIEW          SESSION DOMAIN: CNM01   OPER1   05/17/95 14:40:53
NPDA-45A        * RECOMMENDED ACTION FOR SELECTED EVENT *   PAGE 1 OF 2
CNM01          CENTRAL   LN08PTP   PU32768
DOMAIN         +-----+
               | COMC |----LINE----| CTRL |
               +-----+

USER   CAUSED - LSL 2 REMOTE DSU/CSU IN TEST MODE
                LSL 2 REMOTE DSU/CSU IN CONFIGURATION MODE
                LINE SWITCHED TO INCORRECT POSITION
ACTIONS - D001 - CORRECT THEN RETRY

INSTALL CAUSED - LSL 2 REMOTE DSU/CSU ADDRESS INCORRECT
                 LSL 2 DSU/CSU'S SPEED MISMATCH
                 PHYSICAL LINE CONNECTIONS
ACTIONS - D225 - CORRECT ADDRESS FROM DSU/CSU CONTROL PANEL
          D001 - CORRECT THEN RETRY
          D238 - PERFORM REMOTE DSU/CSU PROBLEM DETERMINATION

ENTER ST (MOST RECENT STATISTICS), DM (DETAIL MENU), OR D (EVENT DETAIL)

???
```

Figure 30. Recommended Action Panel for Selected Event

I-number and E-number actions do not have associated NetView-supplied panels. However, the NetView program allows users to overlay I-numbers and E-numbers with action numbers, to create panels that are specific to the sending product.

You can do this by modifying either table BNJDNUMB, which correlates a Product Set ID with action numbers, or table BNJDNAME, which correlates a Product Common Name with action numbers. BNJDNUMB is searched before BNJDNAME.

Modify table BNJDNUMB or BNJDNAME in NETVIEW.V5R1M0.BNJPNL2 and create BNJwwwwww PDS members.

Modifying BNJDNUMB, BNJDNAME, and BNJwwwwww

This section uses the names BNJDNUMB and BNJwwwwww to indicate a PDS member.

BNJDNUMB

BNJDNUMB correlates a product-set identification (PSID) with a unique file or PDS member (BNJwwwwww) that contains the action numbers to use for this product. To modify BNJDNUMB, use an editor such as ISPF/PDF.

Note: If the NetView program receives a generic alert whose PSID does not exist in BNJDNUMB and whose product common name does not exist in BNJDNAME, the default I-number or E-number is not modified.

The format for BNJDNUMB follows:

```

xxx
yyyyyyyyy BNJwwwwww    comment
.           .           .
.           .           .
.           .           .
```

Where:

Customizing Hardware Monitor Displayed Data

xxx Specifies the number of entries in BNJDNUMB. This number must begin in column 1 and should be three characters long with leading zeros, if necessary.

yyyyyyyyy

Specifies up to nine characters representing the PSID. This entry must begin in column 1.

BNJ*wwwww*

Is the name of the PDS member beginning in column 11, that contains generic alert recommended action code points and associated action numbers. Names such as BNJDNUM2, BNJDNUM3, and so forth, are recommended. However, you can use any unique name. The name BNJDNUM1 is already used for generic alerts produced by the hardware monitor.

Entries in BNJDNUMB must be in ascending order. Comment lines contain an asterisk (*) in column 1.

The first line cannot be a comment line. Figure 31 shows an example of BNJDNUMB. In this example, 7-character NetView PSIDs for the various operating systems map the action number file or PDS member used by the NetView program to BNJDNUM1.

```
002
5665361  BNJDNUM1      NETVIEW R2 MVS/370
5665362  BNJDNUM1      NETVIEW R3 MVS/XA
```

Figure 31. Example of BNJDNUMB Table

Determining the PSID: Because the sending product can be either a hardware product or a software product, the PSID is defined as follows:

- For hardware products, the PSID is defined with the four numeric characters identifying the machine type found in the X'00' subfield, Hardware Product Identifier (located in the first X'11' subvector of the first X'10' subvector in the generic alert).
- For software products, the PSID is defined with the nine uppercase alphanumeric characters of the serviceable component identifier in the X'02' subfield, software product serviceable component identifier (located in the first X'11' subvector of the first X'10' subvector in the generic alert).

Note: If the X'02' subvector does not exist, use the seven uppercase alphanumeric characters of the program product number in the X'08' subvector, software product program number (located in the first X'11' subvector of the first X'10' subvector in the generic alert).

Two methods are available to determine the PSID of a generic alert that is logged to the hardware monitor database:

- Select sel# C from Alerts-Static, Alerts-History, or Most Recent Events panels to display a message containing the PSID.
- Make a selection from the Event Detail menu to display page 1 of the PSID panel. This panel displays the sending PSID.

Customizing Hardware Monitor Displayed Data

BNJDNAME

BNJDNAME correlates a product common name with a unique file or PDS (BNJ*wwwww*) that contains the action numbers to use for this product. To modify BNJDNAME, use an editor such as ISPF/PDF.

The format for BNJDNAME follows:

```
xxx  
yyyyyyyyyyyyyyyyyyyyyyyyyyyyyyyyyyyyy BNJwwwww      comment
```

Where:

xxx Specifies the number of entries in BNJDNAME. This number must begin in column 1 and must be three characters long with leading zeros, if necessary.

yyy...y Specifies up to 30 characters representing the software product common name or up to 15 characters specifying the hardware common name.

BNJ*wwwww*

Is the name of the PDS member beginning in column 32, that contains generic alert recommended action code points and associated action numbers. Names such as BNJDNUM2, BNJDNUM3, and so forth, are recommended. However, you can use any unique name. The name BNJDNUM1 is already used for generic alerts produced by the hardware monitor.

comment

Comments must start in column 45.

NetView provides the following data in this PDS member:

```
001  
NETVIEW                BNJDNUM1      NETVIEW PRODUCT
```

Figure 32. Sample BNJDNAME Table

Determining the Product Common Name: Because the sending product can be either hardware or software, the product common name is defined as follows:

- For hardware products, the hardware common name is defined by the EBCDIC characters found in the X'0E' subfield, Hardware Product Common Name (located in the first X'11' subvector of the first X'10' subvector in the generic alert).
- For software products, the software common name is defined by the EBCDIC characters found in the X'06' subfield, Software Product Common Name (located in the first X'11' subvector of the first X'10' subvector in the generic alert).

To determine the product common name of a generic alert that is logged to the hardware monitor database, make selection 2 from the Event Detail menu. This selection will display the common name (hardware or software) of the sending product.

BNJ*wwwww*

Each BNJ*wwwww* member contains generic alert recommended action code points and associated action numbers. To create the BNJ*wwwww* files or members specified in table BNJDNUMB, use an editor such as ISPF/PDF. Each BNJ*wwwww* PDS member should be stored in the first data set in the concatenation string for the DD statement BNJPNL2. This DD statement is in the NetView startup procedure.

Customizing Hardware Monitor Displayed Data

Avoid defining your panel data set with secondary extents when modifying or creating a panel while the NetView program is running. If a secondary extent is defined while NetView is running, a secondary extent failure can occur causing error recovery and loss of a single instance of a request. If a second attempt is made to execute the request, error recovery might succeed in the execution of the request. However, recycling NetView would be required for a full data set.

The format for `BNJwwwww` follows:

```
xxxx      yyyyyyy dnum
.         .       .
.         .       .
.         .       .
```

Where:

`xxxx` Is the 4-character generic alert recommended action code point (EBCDIC version of the recommended action code point as defined by the generic alert architecture). This field must begin in column 1.

`yyyyyy`

Is the 8-character alert ID number (EBCDIC version of the alert ID number as defined in the X'92' subvector architecture). This field is optional. If present, it must begin in column 11.

`dnum`

Is the 4-character unique action number. This field begins in column 21. Action numbers can be any combination of four EBCDIC characters. The limiting factor of the action number is the ability of the ACTION command list to use these four characters and display the associated panel.

Entries in each `BNJwwwww` file or member must be in ascending hexadecimal order. If a nonhexadecimal number is used, it is skipped.

The `BNJwwwww` file or member specified in `BNJDNUMB` or `BNJDNAME` is searched serially until a match is found or the end of the file is reached. After the first * is found in column 1, the serial searching stops.

You can place blanks in the alert ID field, along with specific alert IDs, for a particular action code point.

Figure 33 shows a sample `BNJwwwww` user-defined table.

```
1002      D562
1002    93987791  D890
1002    D2556B79  D777
```

Figure 33. Sample `BNJwwwww` User-Defined Table

For alert `D2556B79`, the code point `1002` uses `D777` as its action number. For alert `93987791`, code point `1002` uses `D890` as its action number. For all other alerts from this sending product, code point `1002` uses `D562` as its action number.

Changing Color and Highlighting for Hardware Monitor Panels

For the hardware monitor displays, you can alter the color, highlighting, and intensity of the display's text. You can also enable the display to produce an audible alarm. Consider the needs of the display users before you modify these four attributes as assigned by the NetView program.

Customizing Hardware Monitor Displayed Data

Note: Changing the length of any attribute, row placement, or column placement will yield unpredictable results.

For any string of display text that is preceded by a blank, you can modify up to four attributes as follows:

Color	Text is red, yellow, blue, white, green, turquoise, or pink.
Highlighting	Text is underscored, blinking, or in reverse video.
Intensity	Text is more intense (monochrome terminals only).
Alarm	Text causes an audible alarm at the user's terminal.

You can change these attributes for specific displays or for all displays. For example, you can select a single color for prompt lines on all displays.

The procedure for modifying these attributes begins with a color map. A color map is a table that embeds characters, representing the various attributes, in a color buffer. These characters in the color buffer control the appearance of the text.

The automation table can also be used to set or change the color and highlighting of specific alerts for hardware monitor display.

Reference: For more information, refer to the *Tivoli NetView for z/OS Automation Guide*.

Selecting the Color Map

The first step in modifying a hardware monitor display is to determine which color map controls the display you want to change. "Appendix A. Color Maps for Hardware Monitor Panels" on page 177, contains a matrix of the panel name, panel number, and color map for hardware monitor panels.

After you identify the color map you need, edit the map using an editor such as ISPF/PDF. The color maps are contained in the PDS named NETVIEW.V5R1M0.BNJPNL2 (unless the name is changed during installation). The member name is the color map name.

Note: If you want a particular attribute to apply to the same portion of **each** panel, modify the color map BNJOVERW, which overwrites all other panel-specific color maps. Be sure to test the results of BNJOVERW on each panel before putting it into your production system. This map can produce unexpected results.

Modifying the Color Map

After you select the color map, you can modify it. A color map consists of a series of lines of data, called map elements. The top line of a color map is always the number of subsequent map elements. Map elements begin in column 1, and are paired with comments that begin in column 41.

Each map element specifies, for a particular display row, the attribute, the attribute's placement in the row, and the length in characters. Each item in the map is followed by a comma, except for the last one, which is followed by a period.

Note: Changing any attribute's length, row placement, or column placement can yield unpredictable results.

Customizing Hardware Monitor Displayed Data

Figure 34 shows a sample color map. Explanations of the numerical references follow on pages 87–88.

13, 1	NUMBER OF ELEMENTS IN TABLE
1,1,1,79,BLU, 2	NETVIEW HEADER
1,2,1,14,BLU,	SCRN ID
2,2,16,64,HIG,WHI,	SCRN TITLE
1,3,1,7,BLU,	DOMAIN
1,3,9,71,TUR,	
1,5,1,79,BLU,	HEADING
99,SIZE-0-7,2, 3	REPETITION
2,6,1,4,HIG,WHI,	SEL #
1,6,6,74,TUR,	DATA
1,SIZE-4,1,50,BLU, 4	PROMPT LINE
2,SIZE-4,52,1,HIG,WHI,	PROMPT LINE
1,SIZE-4,54,26,BLU,	PROMPT LINE
1,SIZE-3,1,79,BLU.	PROMPT LINE

Figure 34. Sample Color Map

1 The first item in the color map represents the number of subsequent lines of data, or map elements. A map can have any number of map elements. The sample map has 13 map elements.

2, **3**, and **4** describe the three types of map elements as follows:

2 This type of map element contains attribute information in the following format:

- The first item is the number of attributes in the map element. This number can be 1–4. A map element might have only one set of attributes, for example, pink color, or any combination of attributes, such as pink color and underscoring. The sample map element has one attribute, the color blue (BLU).
- The second item is the number of the display row that reflects the attribute. In the sample, the attribute is to appear in row 1.
- The third item is the number of the display column that contains the attribute character. In the sample, the attribute character is to be placed in column 1. Consequently, the displayed text will begin in column 2.

Note: Be sure that the display text you want to modify is preceded by a blank space. Otherwise, the character representing the attribute in the color buffer overwrites some of the display text, and some characters are replaced with blanks. For example, in the following string you cannot make the colon a different color from the text:

```
EVENT DESCRIPTION:PROBABLE CAUSE
```

- The fourth item is the maximum character length of the attribute. In the sample, the specified attribute covers 79 characters on the display, or columns 2–80.
- The last item is the attribute or sequence of several attributes. In the sample, the color blue is the specified attribute. You can specify up to four attributes, but only one from each category. If you want multiple attributes to apply to the same character or string, you must specify the attributes for each category in this order:
 1. Alarm: ALM produces an audible alarm.
 2. Intensity:
 - HIG intensifies the color.
 - NOH returns the color to normal intensity.
 3. Highlighting:

Customizing Hardware Monitor Displayed Data

- UND underlines the character or string.
 - BLI causes the character or string to blink.
4. Color:
- RED produces red.
 - YEL produces yellow.
 - BLU produces blue.
 - WHI produces white.
 - GRE produces green.
 - TUR produces turquoise.
 - PIN produces pink.

This map element makes the text in row 1, columns 2–80, blue. As the map element's corresponding comment confirms, this blue string of text is the display header.

3 This type of map element uses the repetition factor option to copy the attribute or attributes specified for a particular row onto subsequent rows. A repetition map element uses the following format:

- The number 99 signals the repetition of an element.
- In SIZE-*x-y*:
 - SIZE represents the total number of rows in the panel. Use the word SIZE as shown; do not replace it with a number.
 - *x* is the number of unused or blank lines between the end of the panel data and the prompt line. In the sample, no blank or unused lines occur between the end of the panel data and the prompt line.
 - *y* is the number of the starting row that is to copy, or repeat, the attribute or attributes from the preceding row. In the sample, attributes from row 6 are to be repeated on the subsequent rows, starting with row 7.
- The last item (2) is the number of attributes on row 6 that are repeated. In the sample, the two attributes specified in the map for row 6 are to be repeated.

This map element copies the two attributes specified for row 6 onto subsequent rows starting at row 7, and continues to the prompt line.

4 This type of map element uses the variable row placement option to specify the row that contains the attribute. This option uses the following format:

- The first item (1) is the number of attributes in the map element. This number can be 1–4. In the sample, the map element has one attribute, the color blue (BLU).
- The second item (SIZE-*x*) indicates the display row that reflects the attribute, where:
 - SIZE represents the total number of rows in the display. Use the word SIZE as shown; do not replace it with a number.
 - *x* is the number of lines above the command line. For example, for the Alerts-Static display:
 - SIZE-4 is the first prompt line.
 - SIZE-3 is the second prompt line.
 - SIZE-2 is the message line.
 - SIZE-1 is the NetView status line.
 - SIZE-0 is the command line.

In the sample, the attribute is to appear on the first prompt line.

Customizing Hardware Monitor Displayed Data

Note: Be sure that the command line is defined on byte 80 of the NetView status line. Otherwise, some bytes can be overwritten.

- The third item (1) is the number of the display column that contains the attribute character. In the sample, the attribute character is placed in column 1. Consequently, the displayed text begins in column 2.

Note: Be sure that the display text you want to modify is preceded by a blank space. Otherwise, the character representing the attribute in the color buffer overwrites some of the display text, and some characters are replaced with blanks.

- The fourth item (50) is the maximum character length of the attribute. In the sample, the specified attribute covers 50 characters on the display.
- The last item (BLU) is the attribute or sequence of several attributes. You can specify up to four attributes, but only one from each category. If you want multiple attributes to apply to the same character or string, you must specify the attributes in the order shown on page 87. In the sample, the color blue is the specified attribute.

This sample map element makes the text in the first prompt line, columns 2–51, blue.

Prompt Highlight Tokens

The prompt highlight token table BNJPROMP is located in the PDS named NETVIEW.V5R1M0.BNJPNL2. You can modify this table. The maximum size of the table is 25 prompts, with the prompt being a 15-byte character field. If you decide to modify the table, use the Comment column for notes about the table. For performance reasons, this table is not processed when building the Alert Dynamic panel. Color is a 3-byte character field beginning at column 20. You can select only those colors that are valid in the color maps. Table 17 is a sample of the format for the prompt highlight token table.

Table 17. Prompt Highlight Tokens

Prompt Token	Color	Comment
SEL#	WHI	PROMPT SEL#
LDM	WHI	PROMPT LDM
LSL1	WHI	PROMPT LSL1
LSL2	WHI	PROMPT LSL2
RESNAME	WHI	PROMPT RESNAME
RESNAME1	WHI	PROMPT RESNAME1
RESNAME2	WHI	PROMPT RESNAME2
'A'	WHI	PROMPT A
'B'	WHI	PROMPT B
'P'	WHI	PROMPT P
'EV'	WHI	PROMPT EV
'ST'	WHI	PROMPT ST
'DM'	WHI	PROMPT DM
'M'	WHI	PROMPT M
'DEL'	WHI	PROMPT DEL
'S'	WHI	PROMPT S

Customizing Hardware Monitor Displayed Data

Table 17. Prompt Highlight Tokens (continued)

Prompt Token	Color	Comment
'D'	WHI	PROMPT D
'R'	WHI	PROMPT R

The table is read into storage at initialization. You can redefine the prompt highlight tokens or add new ones, up to a maximum of 25. You receive a message if the table is not successfully read at initialization.

Using NMVT Support for User-Written Programming

Network management vector transport (NMVT) support enables user-written programs to report errors to the hardware monitor through generic alerts. Prior to generic alerts, Recommended Action panels, Event Detail panels, and alert messages were stored at the host in the NetView program. Each nongeneric alert had a unique set of panels and messages.

Note: The original NMVT encoding contains many SNA major vectors including Alerts. Subsequent encoding such as MDS_MU and CP_MSU contains many of the same major vectors and are covered under the term NMVT in this section.

Coded generic alerts are contained in the NMVT. Generic alert code points are used to dynamically build the hardware monitor panels. Nongeneric alerts are used mainly for migration purposes. You should create new user-defined alerts using generic alerts.

Reference: For more information on major vectors and subvectors of an NMVT, refer to the *SNA* library.

This section contains a sample generic alert and the associated panels that are built by the hardware monitor. (See Figure 35 on page 93 through Figure 39 on page 97.) This section also describes how each panel is built.

User-Defined Alerts (Nongeneric)

Sixteen block IDs (X'F00'–X'F0F'), which are part of NMVT major vector X'0000', are reserved for generating user-defined alerts.

The hardware monitor reserves USER0**bb**–USERF**bb** (where **bb** are required blank space X'40' characters to pad the name to 7 characters) for use as the corresponding 7-character software identifier in the software product program number (X'08') subfield of the first product identifier (X'11') subvector of the NMVT. These are mapped to the block IDs from X'F00' to X'F0F'.

The hardware monitor allows a 1-byte alert description code within the basic alert (X'91') subvector of the NMVT. This code lets you further qualify the alert. Put your alert description code in the second byte of the 2-byte Alert Description Code field. The hardware monitor ignores the first byte of that field.

NMVT-to-Panel ID Mapping

Using the block ID derived from the software product program number and the alert description code, the hardware monitor maps the NMVT to the following:

- 14-line panel

Customizing Hardware Monitor Displayed Data

A 14-line panel appears on the Recommended Action panel of the hardware monitor for the NMVT. The PDS member name for this 14-line panel is in the range between BNIF00xx and BNIF0Fxx, where the range of block IDs is from X'F00' to X'F0F', and xx is the hexadecimal value of the alert description code. The lines can be up to 80 characters long.

- 7-line panel

A 7-line panel appears on the hardware monitor's event detail panel for the NMVT. The 7-line panel's PDS member name is in the range between BNKF00xx and BNKF0Fxx, where the range of block IDs is from X'F00' to X'F0F', and xx is the hexadecimal value of the alert description code.

The first eight translated characters of each of the first three X'A0' or X'A1' qualifier subvectors are displayed on an eighth line, immediately following the Event Detail panel. Write the Event Detail messages, with titles on the seventh line, to describe the qualifiers.

- 48-byte alert description

A 48-byte alert description appears on the Alerts-Dynamic, Alerts-Static, Alerts-History, Event Detail, and Most Recent Events panels. The 48-byte text descriptions for a block ID are in a NetView message CSECT whose link-edit load module name is in the range between BNJVMF00 and BNJVMF0F.

Panel Formats

For each new Recommended Action panel or Event Detail panel, use the same format as in the existing panels to add a panel to the NetView panel library or a concatenated user library.

For each new 48-byte alert description CSECT, use the same format as an existing BNJVMxxx CSECT. BNJVMxxx CSECTs are coded using the macro DSIMDS. No variable substitution is permitted for 48-byte alert descriptions.

User-Defined Alerts (Generic)

Generic alerts allow coded alert data to be transported within the alert, eliminating the need for stored panels. The coded data can be one of the following:

- An index into predefined tables, containing short units of text that are used to build a panel
- Textual data that appears directly on the panel

Coded data is maintained in code point tables which can be customized (For more information on customizing code point tables, see "Modifying Generic Code Point Tables" on page 99). The text strings indexed by the code points, and the display of textual data that was sent in the alert, are in the same format no matter which product sent the alert. Also, the same terminology is used to define similar problems within different products because each product uses terminology defined by Tivoli.

Generic alerts produce the same Alerts, Recommended Action, and Detail panels as the hardware monitor's nongeneric alert support, but the panels are built dynamically rather than using stored panels. Code points index into the tables defined by Tivoli and the user.

The alert description and probable cause code points are used to build the hardware monitor Alerts-Dynamic, Alerts-Static, Alerts-History, Event Detail, and Most Recent Events panels. The user cause, install cause, failure cause, and recommended action code points are used to build the hardware monitor Recommended Action panel. The detail data code points are used to identify the

Customizing Hardware Monitor Displayed Data

qualifiers that can appear on the hardware monitor Recommended Action or Event Detail panel. Products use the same set of architected product-independent terminology to define their Alert, Recommended Action, and Detail panels. Text data transported in the NMVT is displayed on the Event Detail panel.

The NetView program ships generic code point tables that can be customized (for more information on customizing code point tables, see “Modifying Generic Code Point Tables” on page 99.). The generic code point tables shipped by NetView are:

- BNJ92TBL—Alert description code points
- BNJ93TBL—Probable cause code points
- BNJ94TBL—User cause code points
- BNJ95TBL—Install cause code points
- BNJ96TBL—Failure cause code points
- BNJ81TBL—Recommended action code points
- BNJ82TBL—Detail data code points
- BNJ85TBL—Detailed data code points, subfield X'85'
- BNJ86TBL—Actual action code points.

Using the GENALERT Command

You can use the GENALERT command to create your own alerts. The GENALERT command is described in the NetView online help.

Building Generic Alert Panels

Figure 35 on page 93 is an example of a generic alert NMVT. Unique panels are built using the information contained in a generic alert record.

Reference: For more information on NMVTs, refer to the *SNA* library.

Customizing Hardware Monitor Displayed Data

```

X'41038D5002000000'
X'01230000'
X'0A0108105901020A2827'
X'0B92000001'
X'1603'
X'1A2B3C4D'
X'0693'
X'0403'
X'2012'
X'1195'
X'0601'
X'1502'
X'13E1'
X'038391'
X'0681'
X'0101'
X'1504'
X'2796'
X'0601'
X'0503'
X'33C2'
X'068200'
X'61'
X'0004'
X'0C8200'
X'53'
X'11F0F0406040F1C6'
X'0A81'
X'0611'
X'0500'
X'3110'
X'00E1'
X'038321'
X'1705'
X'151000'
X'07D7E4F9F9F9F900F1'
X'07D3C9D5C5F0F440F9'
X'4D1000'
X'341104'
X'0E02C1C3C661C9C2D44040F0F0F3'
X'0804F0F1F0F2F0F3'
X'0A06C1C3C661C9C2D440'
X'0A07C6C6C7C1C9E3D9F3'
X'07098603351225'
X'161101'
X'130012'
X'F9F9F9F9F1F1C1F0F5'
X'F0C1F0C1F0C1F0'
X'1798'
X'0782213400'
X'0004'
X'0782000911'
X'F2F2'
X'0782000E00'
X'00DC'
X'2548'
X'1060'
X'D7C3C9C4D3E4F0F4'
X'05C3D5D4F0F1'
X'0D82'
X'00DA11C3D6D4D460C5D9D9'
X'068200D1010F'
X'3631'
X'060211340500'
X'0512C5D5E4'
X'032112'
X'2630'
X'E3C8C9E240E2E4C2C6C9C5D3C440C9C4C5D5E3C9C6C9C5E240E3C8C540E3C5E7E340D4E2'

Response Header
Major Vector Length and Key
01 SV - Date/Time
92 SV - Alert Description
code point
93 SV - Probable Cause(s)
code point
code point
95 SV - Install Cause(s) and Action(s)
01 SF - install cause(s)
code point
code point
83 SF - qualifier(s)
81 SF - recommended action(s)
code point
code point
96 SV - Failure Cause(s) and Action(s)
01 SF - failure cause(s)
code point
code point
82 SF - qualifier(s)
code point
82 SF - qualifier(s)
code point
81 SF - recommended action(s)
code point
code point
code point
code point
83 SF
05 SV - Resource Hierarchy
10 SF
name/type pair
name/type pair
10 SV - PSID
11 SV - Product Identifier
02 SF - software product serviceable component ID
04 SF - software product common level
06 SF - software product common name
07 SF - software product customization ID
09 SF - software product customization date and time
11 SV - Product Identifier
00 SF - hardware product identifier
98 SV - Detailed Data
82 SF - qualifier
82 SF - qualifier
82 SF - qualifier
48 SV - Correlation
60 SF - correlation for supporting data
82 SF - qualifier
82 SF - qualifier
31 SV - Self Defining Text Message
02 SF - Coded Character Set ID
12 SF - National Language ID
21 SF - Sender ID
30 SF - Text Message

```

Figure 35. Sample Generic Alert Record

Figure 36 on page 94 through Figure 38 on page 97 describe how each unique panel is built using the information contained in a generic alert NMVT. Figure 36 on page 94 shows a sample Alerts-Dynamic panel. Explanations of the numerical references follow the panel.

Customizing Hardware Monitor Displayed Data

Alerts-Dynamic Panel

```

N E T V I E W          SESSION DOMAIN: CNM01   OPER1   03/01/95 14:41:03
NPDA-30A              * ALERTS-DYNAMIC *

DOMAIN RESNAME  TYPE  TIME  ALERT DESCRIPTION:PROBABLE CAUSE
CNM01  PU9999  *LINE 14:41 COMM SUBSYSTEM FAILURE:COMM SUBSYSTEM CTRL  +
           1    2           3           4           5

DEPRESS ENTER KEY TO VIEW ALERTS-STATIC

???
CMD==> _

```

Figure 36. Sample of Alerts-Dynamic Panel

An entry on the Alerts-Dynamic panel is built from a number of subvectors (X'92', X'93', and X'05'). Figure 35 on page 93 creates the results for Figure 36.

- 1** The RESNAME and TYPE come from the last name and type pair in the X'05' subvector. The sample display shows a RESNAME of PU9999 and a TYPE of LINE.
- 2** The * indicates that the RESNAME preceding the TYPE does not belong to the TYPE. The TYPE is always associated with the last name in the hierarchy, but the name depends on how the X'05' is coded. The Do Not Display Resource Name Indicator bit is set to 1 for the last name and type pair (subvector X'05', subfield X'10', second name and type pair, eighth byte, second bit).
- 3** The ALERT DESCRIPTION is derived from code point X'1603' in the X'92' subvector. The code point provides an index into a table containing the alert description text messages. The sample shows an ALERT DESCRIPTION of COMM SUBSYSTEM FAILURE.
- 4** The PROBABLE CAUSE is derived from code point X'0403' in the X'93' subvector. The code point provides an index into a table containing the probable cause text messages. The sample shows a PROBABLE CAUSE of COMM SUBSYSTEM CTRL.
- 5** The + is included because the X'93' subvector in Figure 36 contains more than one probable cause code point. The + indicates that more probable causes can be seen on the Event Detail panel.

Figure 37 on page 95 shows a sample Recommended Action panel. Explanations of the numerical references follow the panel.

Recommended Action for Selected Event Panel

```

N E T V I E W          SESSION DOMAIN: CNM01   OPER1   03/01/95 14:41:17
NPDA-45A              * RECOMMENDED ACTION FOR SELECTED EVENT *   PAGE 1 OF 1
CNM01      PU9999     LINE04  1
      +-----+
      |  PU  |-----LINE---- 2
      +-----+

USER      CAUSED - NONE 3

INSTALL CAUSED - INCORRECT MICROCODE FIX 4
                INCORRECT SOFTWARE GENERATION: ACF/IBM 5
ACTIONS - I013 - VERIFY X.25 SUBSCRIPTION NUMBER 6
          I085 - APPLY CORRECT SOFTWARE LEVEL

FAILURE CAUSED - COMMUNICATIONS SUBSYSTEM 7
                LINE ADAPTER MICROCODE
                ADAPTER NUMBER 04 8
                LINE ADDRESS RANGE 00 - 1F 9
ACTIONS - I032 - DUMP CHANNEL ADAPTER MICROCODE 10
          I026 - RUN APPROPRIATE TRACE
          I136 - CONTACT COMMUNICATIONS SYSTEMS PROGRAMMER
          I010 - PERFORM 9999 PROBLEM DETERMINATION PROCEDURES
                11

ENTER DM (DETAIL MENU) OR D (EVENT DETAIL)

???
CMD==> _
    
```

Figure 37. Sample of Recommended Action for a Selected Event Panel

The Recommended Action panel is built from a number of subvectors (X'94', X'95', and X'96') and subfields (X'01', X'81', X'82', and X'83').

1 The resource names (PU9999 and LINE04) are taken from the X'05' hierarchy names list subvector. In Figure 35 on page 93, only names from the X'05' subvector are used because the Hierarchy Complete Indicator bit (byte 2 bit 0) in the indicator bit X'05' subvector is set to X'0'. If this bit was set to 1, the NetView program would concatenate the names in the X'05' subvector to the names supplied by VTAM.

2 The resource types (PU and LINE) are derived by converting the type codes in the X'10' subfield of the X'05' subvector (X'F1' and X'F9') into displayable resource types. For more information on changing resource types, see "Adding or Modifying Resource Types" on page 102.

3 The X'94' subvector (NONE) carries user-caused information. Because the X'94' subvector is not included in Figure 35 on page 93, user-caused information is not displayed.

4 The two install-caused probable causes:
 INCORRECT MICROCODE FIX
 INCORRECT SOFTWARE GENERATION:

are built from code points (X'1502' and X'13E1') in the X'01' subfield within the X'95' subvector. The E in the X'13E1' code point indicates an X'83' subfield is needed to complete the install cause.

Customizing Hardware Monitor Displayed Data

5 The qualifier on the install cause (ACF/IBM) is displayed because of the X'83' subfield of the X'95' subvector. The X'83' subfield contains the value X'91' indicating that the qualifier is taken from the product ID subfield (X'06' Software Product Common Name) of the first product identifier subvector (X'11').

6 The two install-caused actions:

I013 - VERIFY X.25 SUBSCRIPTION NUMBER
I085 - APPLY CORRECT SOFTWARE LEVEL

are taken from code points (X'0101' and X'1504') in the X'81' subfield of the X'95' subvector.

7 The two failure-caused probable causes:

COMMUNICATIONS SUBSYSTEM
LINE ADAPTER MICROCODE

are taken from code points (X'0503' and X'33C2') in the X'01' subfield of the X'96' subvector. The C in the X'33C2' code point indicates that two detail data subfields, either X'82' or X'85' subfields, are needed to complete the failure cause. This example uses X'82' subfields. While either X'82' or X'85' subfields can be used here, a combination of the two would not be valid. Within a subvector, all of the detail qualifiers must be X'82' subfields or X'85' subfields.

8 Indicates the ADAPTER NUMBER 04 is broken down from the first X'82' subfield in the X'96' subvector. The number can be:

00 No information is taken from the PSID subvector
61 A code point for adapter number
00 Hexadecimal data follows
04 Hexadecimal data to be displayed

9 LINE ADDRESS RANGE 00 - 1F is broken down from the second X'82' subfield in the X'96' subvector. The range can be:

00 No information is taken from the PSID subvector
53 A code point for line address range
11 EBCDIC data follows
F0F0406D40F1C6
EBCDIC data to be displayed

10 The failure-caused actions:

I032 - DUMP CHANNEL ADAPTER MICROCODE
I026 - RUN APPROPRIATE TRACE
I136 - CONTACT COMMUNICATIONS SYSTEMS PROGRAMMER
I010 - PERFORM 9999 PROBLEM DETERMINATION PROCEDURES

are taken from the code points (X'0611', X'0500', X'3110', and X'00E1') in the X'81' subfield of the X'96' subvector. The E in the X'00E1' code point indicates that an X'83' subfield is needed to complete the failure cause.

11 The qualifier on the failure cause (9999) is displayed because of the X'83' subfield of the X'96' subvector. The X'83' subfield contains the value X'21', indicating that the qualifier is taken from the first hardware PSID subfield (X'00') of the PSID subvector (X'11').

Figure 38 on page 97 and Figure 39 on page 97 show sample Event Detail panels. Explanations of the numerical references follow the figures.

Event Detail Panel

```

N E T V I E W          SESSION DOMAIN: CNM01   OPER1   03/20/95 14:41:32
NPDA-43S              * EVENT DETAIL *      PAGE 1 OF 2

CNM01      PU9999     LINE04  1
+-----+
DOMAIN     |  PU  |----LINE---- 2
+-----+

DATE/TIME: RECORDED - 01/02 10:41   CREATED - 03/20/95 10:40:39 3

EVENT TYPE: PERMANENT 4

DESCRIPTION: COMMUNICATIONS SUBSYSTEM FAILURE 5
PROBABLE CAUSES:
  COMMUNICATIONS SUBSYSTEM CONTROLLER 6
  TOKEN-RING LAN

QUALIFIERS:
  1) 9999 COMMUNICATION CONTROL UNIT 0004 7

ENTER A (ACTION) OR DM (DETAIL MENU)

???
CMD==> _
    
```

Figure 38. Sample of Event Detail Panel (Page 1)

```

N E T V I E W          SESSION DOMAIN: CNM01   OPER1   03/20/95 14:41:49
NPDA-43S              * EVENT DETAIL *      PAGE 2 OF 2

CNM01      PU9999     LINE04
+-----+
DOMAIN     |  PU  |----LINE----
+-----+

QUALIFIERS (CONTINUED):
  2) EVENT CODE 22
  3) REASON CODE 00DC

CONTROL PROGRAM TEXT: 8
  THIS SUBFIELD IDENTIFIES THE TEXT MS

CORRELATION FOR SUPPORTING DATA 9
  PCID: PCIDLU01      NETWORK QUALIFIED NAME: CNM01
  1) LOG ID COMM_ERR
  2) LOG RECORD NUMBER 15

UNIQUE ALERT IDENTIFIER: PRODUCT ID - ACF/IBM 10      ALERT ID - 1A2B3C4D 11

ENTER A (ACTION) OR DM (DETAIL MENU)

???
CMD==> _
    
```

Figure 39. Sample of Event Detail Panel (Page 2)

The Event Detail panel is built from subvectors X'92', X'93', X'98', X'01', X'31', and X'48', and subfield X'82'.

1 The resource names (PU9999 and LINE04) are taken from the X'05' hierarchy names list subvector. In Figure 35 on page 93, only names from the X'05' subvector

Customizing Hardware Monitor Displayed Data

are used because the Hierarchy Complete Indicator bit (byte 2, bit 0) in the X'05' subvector is set to X'0'. If this bit was set to 1, the NetView program would concatenate the names in the X'05' subvector to the names supplied by VTAM.

2 The resource types (PU and LINE) are derived by converting the type codes in the X'10' subfield of the X'05' subvector (X'F1' and X'F9'), into displayable resource types. For more information on changing resource types, see "Adding or Modifying Resource Types" on page 102.

3 The DATE/TIME RECORDED is the time the record is logged to the hardware monitor database. The created field shows the time the record was created by the sending product. It is taken from the X'10' subfield of the X'01' subvector.

4 EVENT TYPE is derived from byte 4 (Alert Type) the X'92' subvector.

5 DESCRIPTION is derived from the code point (X'1603') in the X'92' subvector, as is the description on the Alerts panel. However, a longer version of the text is displayed on this panel.

6 PROBABLE CAUSES are taken from the code points (X'0403' and X'2012') in the X'93' subvector. A longer version of the text is displayed on this panel than was displayed on the Alerts panel. Also, all of the probable causes are displayed.

7 QUALIFIERS are derived from either X'82' or X'85' subfields. The NetView program ignores X'01' subfields and associated sub-subfields (including X'82' and X'85') in a X'98' subvector.

While either X'82' or X'85' subfields can be used here, a combination of the two would not be valid. Within a subvector, all of the detail qualifiers must be X'82' subfields or X'85' subfields.

This example uses X'82' subfields, and the qualifiers are decoded as follows:

First in the X'98' subvector:

- 21** Data should be taken from the first hardware PSID subfield (X'00') of the PSID subvector (X'11).
- 34** Code point indicating communication control unit.
- 00** Hexadecimal data follows.
- 0004** Hexadecimal data to be displayed.

Second in the X'98' subvector:

- 00** No data is taken from the PSID subvector.
- 09** Code point indicating event code.
- 11** EBCDIC data follows.
- F2F2** EBCDIC data to be displayed.

Third in the X'98' subvector:

- 00** No data is taken from the PSID subvector.
- 0E** Code point indicating reason code.
- 00** Hexadecimal data follows.
- 00DC** Hexadecimal data to be displayed.

Page 2 of the Event Detail panel (see Figure 38 on page 97) contains the following information:

Customizing Hardware Monitor Displayed Data

8 CONTROL PROGRAM TEXT is the text title displayed because of the subfield X'21' of subvector X'31'. The text itself is taken directly from subfield X'30' of the X'31' subvector and displayed on the screen.

9 The CORRELATION FOR SUPPORTING DATA is displayed from the X'48' subvector. Subfield X'60' specifies that the network-qualified procedure correlation identifier be used to uniquely identify a session.

Either X'82' or X'85' subfields are used for supporting data. This example uses two X'82' subfields to identify the supporting data.

While either X'82' or X'85' subfields can be used here, a combination of the two is not valid. Within a subvector, all of the detail qualifiers must be X'82' subfields or X'85' subfields.

10 The product ID (ACF/IBM) is taken directly from the first product identifier (X'11') subvector in the first PSID (X'10') subvector. Figure 35 on page 93 uses the Software Product Serviceable Component Identifier (X'02') subfield.

11 The alert ID number (1A2B3C4D) is taken from subvector X'92' bytes 7–10.

Modifying Generic Code Point Tables

This section explains how to modify the generic alert code point tables that are shipped with the NetView program. You can modify the tables before or after NetView initialization. If after, use the CPTBL command to dynamically activate the changes. The CPTBL command is described in NetView online help.

Table Formats

Each table contains a different type of code point. The tables are:

- BNJ92TBL: Alert description code points
- BNJ93TBL: Probable cause code points
- BNJ94TBL: User cause code points
- BNJ95TBL: Install cause code points
- BNJ96TBL: Failure cause code points
- BNJ81TBL: Recommended action code points
- BNJ82TBL: Detail data code points
- BNJ85TBL: Detail data code points, X'85' subfield
- BNJ86TBL: Actual action code points.

The fourth and fifth characters of the table name identify the subvector or subfield that contains the code points.

The first entry in the code point table is the control entry. Columns 1 and 2 represent the subvector number which specifies which of the code point tables is being created or updated. Acceptable values are 92, 93, 94, 95, 96, 81, 82, 85, or 86. During initialization, this number must match the table name. Column 3 must be blank and all remaining columns are unused and are ignored. (You should not use this area for comments because it may be used for other purposes in the future.) When using the CPTBL command, the name of the file that contains the code point definitions does not have to be one of the predefined names. NetView uses this control entry to determine the table type.

The format of each subsequent entry in the code point table is:

Customizing Hardware Monitor Displayed Data

- Columns 1–4 contain the 4-character hexadecimal code point number. Valid characters are 0–9 and A–F. The code point range from X'E000' to X'FFFF' is reserved for your use. To use code points outside this range, contact the Tivoli Support Center.
If a code point is defined more than once in a given table, the first entry is used, subsequent entries are ignored, and an informational message is generated.
- Column 6 contains the embed flag (Y) indicating that qualifier data associated with the X'82', X'83', or X'85' subfield is placed before the code point's text, embedded within the code point's text, or follows on the same line after the code point's text. Any character other than Y indicates that the embed flag is off. If the embed flag is turned on, the embed information included in the generic alert is embedded at the point marked by a dollar sign (\$). Embedded text is only supported for BNJ81TBL, BNJ86TBL, BNJ94TBL, BNJ95TBL, and BNJ96TBL. Because no variable substitution is allowed for probable cause and alert description, an embed flag is ignored in BNJ92TBL and BNJ93TBL.
- Columns 8–72 contain the text description for this code point. The maximum length of the text varies as follows:
 - Probable cause: 40 characters for the first entry of a given code point, 20 for the second. (See **4** in "Example of BNJ92TBL Code Points Table" on page 101 for an explanation of the second entry.)
 - Alert description: 40 characters for the first entry of a given code point, 25 for the second. (See **4** in "Example of BNJ92TBL Code Points Table" on page 101 for an explanation of the second entry.)
 - Detail data: 40 characters
 - Others: 108 characters.

Start in column 2 when continuing the text on the next line.
- Columns 73–80 are ignored and can be used for optional sequence numbers.

Notes:

1. Code points in table BNJ82TBL must be left-justified and padded with zeros. For example, you enter code point 12 as 1200.
2. The text for the code point entries added to the NetView BNJ81TBL code point table should begin with *Ennn*. The text for the code point entries added to the NetView BNJ86TBL code point table should begin with *Rnnn*. The use of *Ennn* and *Rnnn* allows the code points to be supported by the ACTION command list (for more information on the ACTION command list, refer to the NetView online help). The action text in BNJ81TBL and BNJ86TBL should begin this way. Otherwise, when BNJDNUMB is used to generate recommended action numbers, it overlays the first 4 bytes of the recommended action text.
3. The hardware monitor searches the tables for the specific code points. If a match is not found, the hardware monitor searches some tables for a general code point.
A general code point is the code point with the last 2 bytes set to zero. For example, if the specific code point is 1620, the general code point is 1600. If a general code point is found, its text is returned as if it matched the original code point. A general code point contains text that is valid for all specific code points that it applies to. General code points are not available for BNJ82TBL and BNJ85TBL (for information on general code points, refer to the *SNA* library).
4. All code point tables are in uppercase. However, if you want to enter your own code in lowercase or mixed case, NetView does not convert the text to uppercase.

Use of %INCLUDE Statements

The use of %INCLUDE statements in the code points tables allows you to organize your code points information for easier maintainability.

You can choose to have one main table for each code point type. This table can contain the code points shipped with the NetView program and %INCLUDE statements for user-defined subtables and subtables defined by other products.

BNJxxTBL (where xx is the table number) are tables Tivoli does not recommend modifying. Use these tables as main tables for each code point. If customization of these tables is required, use the BNJxxUTB (where xx is the table number) file which is included by the main table (BNJxxTBL) for this purpose.

Example of BNJ92TBL Code Points Table

An example of a code points table is shown in Figure 40. Explanations of the numerical references follow the figure.

```
* An asterisk in column 1 indicates a comment line.  
* The following line is the control entry indicating table type.  
1 92  
* Blank lines are allowed for readability.  
  
2 %INCLUDE BNJ92UTB  
3 0100 4 SIMPLE CODE POINT TEXT;  
5 E123 THIS TEXT IS EXACTLY FORTY CHARS LONG XX;  
E123 THIS IS THE SAME IN 25 XX;  
6 FFFF
```

Figure 40. Sample of BNJ92TBL Code Points Table

- 1 The first non-comment line is the control entry.
- 2 Code point tables can use %INCLUDE statements to embed other files into the code point table.
- 3 The code point (0100) is a 4-character hexadecimal number, starting in column 1.
- 4 The text description in columns 8–72 appears on the hardware monitor displays.
- 5 The hardware monitor has different panel formats that allow different length text for alert descriptions (92) and probable causes (93). The maximum length of the text for either entry is 40 characters. Abbreviated text is required, if the text exceeds 25 characters for alert descriptions or 20 characters for probable causes. Errors occur for text entries greater than 40 characters.
- 6 Any entries in the table with code point FFFF and no text are ignored (to allow for migration). Entries with code point FFFF and text are treated as any other code point.

Example of BNJ94TBL Code Points Table

Another example of a code points table is shown in Figure 41 on page 102.

Customizing Hardware Monitor Displayed Data

```
* An asterisk in column 1 indicates a comment line.  
* The following line is the control entry indicating table type.  
94  
1 %INCLUDE BNJ94UTB  
2 0100 Y CODE POINTS TEXT WITH DETAIL INSERTS $ AND $  
3 0200 CODE POINTS TEXT ILLUSTRATING CONTINUATION OF THE TEXT TO A SECON  
D LINE  
4 0100 DUPLICATE TEXT
```

Figure 41. Sample of BNJ94TBL Code Points Table

- 1 Code point tables can use %INCLUDE statements to embed other files into the code point table.
- 2 The embed flag (Y in column 6) indicates that qualifier data is embedded at the point marked by a dollar sign (\$).
- 3 Start in column 2 when continuing text on the next line. The text on the first line starts in column 8 and continues through column 72.
- 4 Because this code point has already been defined in the table, this entry is ignored and an informational message is generated.

Activating the Modified Code Point Tables

The CPTBL command is very similar to the AUTOTBL command and is used to dynamically activate changes made to code point tables after NetView is initialized (for a description of the CPTBL command, refer to NetView online help). Use the TEST option on the CPTBL command to verify the syntax of a code point table before activation.

Adding or Modifying Resource Types

You can add new resource types for hierarchical displays in the hardware monitor by modifying the member BNJRESTY.

BNJRESTY is a member of the data set NETVIEW.V5R1M0.BNJPNL2, defined by the definition statement BNJPNL2 in the NetView start procedure.

Figure 42 shows the format for BNJRESTY. Explanations of the numerical references follow the figure.

```
1 2 3  
10 DISK your comments
```

Figure 42. Sample Contents of BNJRESTY

- 1 A 2-character hexadecimal number, starting in column 1, flows to the NetView program in the X'05' subvector. Valid characters are 0–9 and A–F. If you include duplicate hexadecimal codes, the system uses the first entry of the duplicated code. Numbers from X'E0' to X'EF' are reserved for customer-defined resource types.
- 2 The four characters in columns 4–7 are taken as the resource type. Valid characters are 0–9, A–Z, and any printable special characters. A resource type of less than 4 characters must begin in column 4, and be padded on the right with blanks. Do not use delimiters, such as a comma (,), period (.), or equal sign (=), as characters in the resource type.

Customizing Hardware Monitor Displayed Data

3 An optional comment can begin anywhere after the resource type.

If BNJRESTY is modified while the hardware monitor task BNJDSESV is active, the new resource types are not recognized. Use STOP TASK=BNJDSESV followed by STARTCNM NPDA so that the NetView program can recognize any new resource types or use the RTTBL command to activate a modified BNJRESTY member.

If the NetView program finds an entry that is not valid in BNJRESTY during activation of the NetView program or when the RTTBL command is invoked, an error message appears on the command facility console and the NetView program uses the Tivoli-supplied resource types.

Chapter 7. Modifying Network Asset Management Command Lists

Network asset management provides a way of collecting inventory data from a subset of hardware and software devices automatically. You can use network asset management to collect vital product data (VPD) such as serial numbers, machine types, and model numbers for hardware products and software information. This information includes version and release levels. However, the NetView program does not verify the returned data from devices supporting network asset management; it only provides a way to collect and log the data.

Reference: Refer to the *Tivoli NetView for z/OS Administration Reference* for information on the record formats. Refer to the NetView online help for information about NetView-provided command lists.

Any device that supports the REQUEST/REPLY PSID and LPDA-2 architecture can report VPD to the NetView program. An attempt to solicit VPD from a device that does not support the architecture can cause the keyboard to lock or extraneous data to appear on the screen. You may need to press the RESET key or clear the screen, but these actions do not affect the VPD collection in the NetView program.

Reference: Refer to the SNA library for information on the REQUEST/REPLY PSID and LPDA-2 architecture.

The following examples are some physical units (PUs) that support the REQUEST/REPLY PSID architecture:

- 3720/NCP
- 3725/NCP
- 3745/NCP
- 3174 that reports data for itself and many types of attached devices such as various models of 3191, 3192, and 3194 display stations.

Personal computers running OS/2[®] are required with these products.

Reference: Instructions for entering VPD for a device are located in the user's guides for that device. Also, refer to the OS/2 library.

The following are examples of data circuit-terminating equipment (DCE) that supports the LPDA-2 modem and line status architecture:

- 586x modems
- 5822 DSU/CSU
- 7825 DSU/CSU
- 786x modems (7861, 7865, 7868).

Network asset management provides the VPDCMD command to solicit VPD from a given device and the VPDLOG command to build and log a record to an external logging facility (SMF for MVS). You can use Service Level Reporter (SLR) to view the data interactively or to generate reports, or the VPDALL command to generate VPDPDU and VPDDCE command entries for all devices within a NetView domain. If you have any resources that require switched lines, be sure that the switched lines are active before collecting VPD.

Modifying NAM Command Lists

Network asset management provides the following command lists:

VPDPU

Collects and logs VPD from a single PU and its attached devices. You can enter this command list from an operator's console or from another command list.

VPDDCE

Solicits and logs VPD from DCEs that are in a direct path between a specified NCP and a specified PU. You can issue this command list from an operator's console or from another command list.

VPDACT

Is the default name of a command list that the VPDALL command generates when issued with the CREATE option. VPDALL reads a VTAM configuration member in VTAMLST as input and generates a command list called VPDACT (the default). VPDACT contains a list of VPDPU and VPDDCE entries for devices in your domain. You can later issue VPDACT to collect and log VPD from the supported devices in the NetView domain.

VPDLOGC

Is the command list that builds and logs START and END records. A START record is generated for a VPDACT command list at the beginning of a VPD solicitation. An END record is generated for a VPDACT command list at the end of a VPD solicitation. Do not issue this command list from an operator's console or from a user-written command list.

VPDXDOM

Is a service command list used for VPD solicitation from cross-domain resources. This command list is driven through a NetView automation table. Do not issue this command list from an operator's console or from a user-written command list.

Reference: Refer to *Tivoli NetView for z/OS Administration Reference* for the record formats and the NetView online help for descriptions of VPD command lists. Refer to *Tivoli NetView for z/OS Automation Guide* for additional information.

VPD Collection from a Single PU

The following list describes the procedures for collecting VPD from a single PU and its attached devices:

1. Specify a resource name and issue the VPDPU or VPDDCE command list.
2. The command list issues a VPDCMD command to solicit data from the specified resource, and waits for the response messages.
3. A PU responds with VPD for itself, or for itself and its attached devices.
4. The command list traps the response messages and saves the VPD, such as machine type, model number, and serial numbers, in command list variables.
5. When the completion message is received, the command list builds records and writes them to an external logging facility.
6. If any abnormal events occur before completion, a command list error message is issued and the command list terminates. An abnormal event can be a logging failure, an inactive VPDTASK, or an abend.

VPD Collection from a Single NetView Domain

The following list describes procedures for collecting VPD from a single NetView domain:

1. A NetView operator enters the following command:
`VPDALL CONFIG(ATCCON01),CREATE,CLIST(VPDACT),ADD`
2. The VPDALL command list reads the specified nodes from the configuration member (ATCCON01, in this example) in VTAMLST. VPDALL extracts all the resource names from the VTAMLST nodes so that VPD can be collected. VPDALL then builds VPDPFU and VPDDCE entries in a command list called VPDACT. VPDALL does not support dynamic reconfiguration decks (DRDs) or DCEs on switched lines.

Note: To collect data from the entire domain, the configuration member must contain the definitions for all the resources in the domain.

3. You can modify VPDACT by adding or deleting resource names.
4. When the VPDACT command list is executed, VPDLOGC is called to generate a START record. VPDACT then calls the VPDPFU and VPDDCE command lists and, after they are complete, calls the VPDLOGC to generate an END record.

Focal Point VPD Collection

Figure 43 shows a focal point NetView program for VPD.

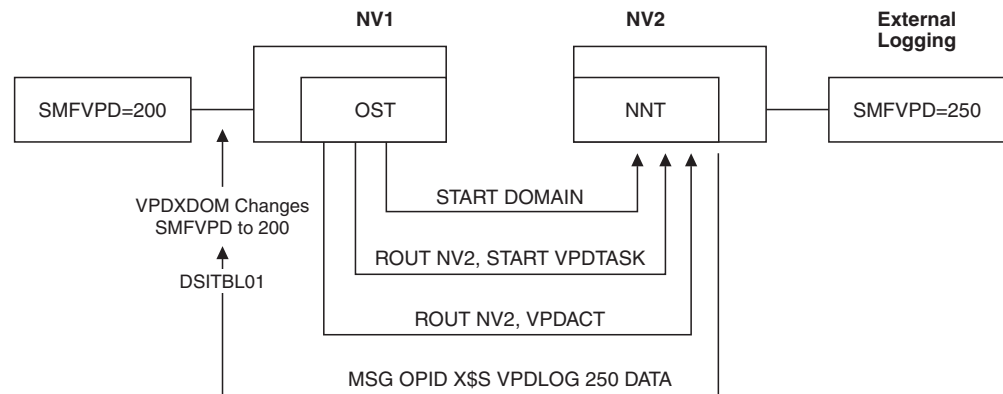

Figure 43. VPD Focal Point NetView Program

The following steps describe the procedures for the collection of VPD for the sample focal point NetView program shown in Figure 43.

1. During installation, NV1 sets the common global variable SMFVPD to 200. NV2 sets the common global variable to 250.

Note: CNMSTYLE sets the common global variable SMFVPD to 37.

2. NV1 is designated as a focal point NetView program for VPD collection. In the NetView automation table (DSITBL01), for NV1 only, uncomment the statement designated to drive the VPDXDOM command list.

Reference: For more information, refer to the *Tivoli NetView for z/OS Installation: Configuring Additional Components*.

3. Start DSIELTSK from the focal point NetView NV1.

Modifying NAM Command Lists

4. NV1 establishes a direct OST-to-NNT session with NV2 using the START DOMAIN command.
5. NV1 issues START VPDTASK.
6. NV1 issues ROUTE NV2, START VPDTASK.
7. NV1 issues ROUTE NV2, VPDACT. This causes the VPDACT command list in NV2 to run under an NNT.
8. In NV2, VPDACT verifies that it is running under an NNT, and generates the following message:

```
MSG OPID X$$ VPDLOG 250 '1 STRING1 10 STRING2...'
```

where X\$\$ is a special string recognized by the NetView automation table.

9. When the VPDACT command list in NV2 writes the generated message to the operator in NV1, the message triggers the NetView automation table to execute the VPDXDOM command list in NV1.

Reference: Refer to *Tivoli NetView for z/OS Automation Guide* for additional information about the VPDXDOM command list.

10. When VPDXDOM is entered, the message string is as follows:

```
DSI039I MSG FROM OPID : X$$ VPDLOG 250 1 STRING1...
```
11. VPDXDOM verifies that NV1 set SMFVPD as a common global variable and changes SMFVPD from 250 (NV2) to 200 (NV1).
12. VPDLOGC logs the data records under NV1's SMF record number 200.
13. Be sure that the cross-domain session stays active until after the VPD solicitation is completed.

Customization Considerations

You can customize the NetView-provided VPD command lists to suit your requirements.

When modifying network asset management command lists to build different record formats, do not exceed 256 bytes per record. NetView has a command string limitation of 240 characters. You can write a command processor to make full use of the VPD command.

Reference: Refer to *Tivoli NetView for z/OS Customization: Using Assembler* for information about command processors.

If you are changing the SMF record format, you cannot use record number 37. You must globally define the SMF record number within the user-defined range of 128–255. If you are using SLR, you must write the SLR table to match your modified SMF record format.

Reference: Refer to NetView online help and *Tivoli NetView for z/OS Customization: Using REXX and the NetView Command List Language* for limitations on the use of &WAIT and RESET, and for considerations regarding the issuance of a second network asset management command list and network asset management command while a previous network asset management command list is running.

To improve performance, you can do the following:

- Write a command list that reads in VPDACT to distribute the workload among several autotasks. Dividing the workload among several OSTs or autotasks

Modifying NAM Command Lists

allows multiple VPDPU or VPDDCE entries to execute simultaneously. Otherwise, the VPDPU and VPDDCE entries are executed serially.

- Create several configuration members (for example, one member for each major node) or, using VPDALL, create several command lists.
- Make each command list run under several tasks, such as an OST and an autotask.

Modifying NAM Command Lists

Chapter 8. Customizing the Event/Automation Service

The event/automation service (E/AS) lets you manage all network events from the platform of your choice. You can use either the Tivoli Enterprise Console or Tivoli NetView for z/OS (NetView) to see a comprehensive list of events in your network.

The Event/Automation Service: Overview

The event/automation service consists of the following services:

- Alert adapter service

The alert adapter service is an event adapter that converts Tivoli NetView for z/OS alerts to console events and forwards the events to the console event server. The alert adapter service collects filtered SNA alerts directly from the NetView hardware monitor and translates the alerts into appropriate console class or subclass instances. To receive alerts from NetView, the event/automation service registers with the NetView PPI. Filtered alerts from the NetView hardware monitor are sent over the PPI to the alert adapter service. All alerts to be converted will match the formats described in the *IBM Systems Network Architecture Management Services Reference*.

- Message adapter service

The message adapter service is an event adapter that converts any message forwarded from NetView message automation into console events. The resulting events are forwarded to a designated event server. The message adapter collects filtered messages directly from the NetView automation table and translates the messages into appropriate console class or subclass instances. To receive messages from NetView, the event/automation service registers with the NetView PPI. Filtered messages from the NetView message automation table are sent over the PPI to the message adapter.

- Event receiver service

The event receiver service receives events from a console server and converts them into SNA alerts. The converted alerts are then forwarded to the NetView hardware monitor where they are filtered and routed to the NetView automation table.

- Alert-to-trap service

The alert-to-trap service is an SNMP sub-agent that converts Tivoli NetView for z/OS alerts to SNMP traps and forwards the traps to an SNMP agent. The alert-to-trap service collects filtered SNA alerts directly from the NetView hardware monitor and translates the alerts into appropriate SNMP trap instances. To receive alerts from NetView, the event/automation service registers with the NetView PPI. Filtered alerts from the NetView hardware monitor are sent over the PPI to the alert-to-trap service. All alerts to be converted will match the formats described in the *IBM Systems Network Architecture Management Services Reference*.

- Trap-to-alert service

The trap-to-alert service receives events from an SNMP manager and converts them into SNA alerts. The converted alerts are then forwarded to the NetView hardware monitor where they are filtered and routed to the NetView automation table.

For general information about Tivoli event adapters, refer to the *Tivoli Enterprise Console Adapters Guide*.

Starting the Event/Automation Service

The event/automation service (E/AS) can be started from either the MVS system console using a startup procedure, or from the UNIX[®] System Services command shell using a command file. The sample startup procedure installed with the E/AS is IHSAEVNT. The command file used to start the E/AS from the UNIX System Services command shell is IHSAC000.

The environment that the E/AS is started from (either the MVS system console or the UNIX System Services command shell) determines certain operational characteristics of the E/AS as follows:

- The location of default configuration files.
- Whether certain startup parameters can be specified.
- The default output logs for trace/error data.

All other operational characteristics of the E/AS are the same regardless of the startup environment.

For information on installing and starting the E/AS, refer to the *Tivoli NetView for z/OS Installation: Configuring Additional Components*.

Customizing the Initialization of the Event/Automation Service

The event/automation service (E/AS) has a number of configurable settings. A few must be set by the E/AS administrator in order for the E/AS to successfully initialize. For more information, refer to *Tivoli NetView for z/OS Installation: Configuring Additional Components*.

Configurable settings can be set by the E/AS administrator using configuration files, startup parameters, and E/AS modification commands. Some configurable settings can be set using more than one of these methods. Configurable settings are set in the following order, from highest priority to lowest:

- E/AS modification commands are issued to the E/AS after initialization. Any E/AS modification commands that affect a configurable setting change that setting for the duration of the current execution of the E/AS only.
- A configurable setting that is specified as an E/AS startup parameter.
- A configurable setting that is specified in a configuration file.
- The default value of the configurable setting.

E/AS modification commands are discussed fully in the *Tivoli NetView for z/OS Command Reference*.

Defaults for Configurable Settings

The following table lists all configurable settings and their defaults:

Setting	Default	Overridden By
E/AS PPI name	IHSATEC	PPI startup parameter, global initialization file PPI statement

Global initialization file name	Started with IHSAEVNT - IHSAINIT Started with IHSAC000 --/etc/netview/global_init.conf	IHSAINIT startup parameter
Alert adapter configuration file name	Started with IHSAEVNT - IHSAAACFG Started with IHSAC000 --/etc/netview/alert_adpt.conf	ALRTCFG startup parameter, global initialization file ALRTCFG statement
Alert-to-trap configuration file name	Started with IHSAEVNT - IHSAAATCF Started with IHSAC000 --/etc/netview/alert_trap.conf	ALRTTCFG startup parameter, global initialization file ALRTTCFG statement
Trap-to-alert configuration file name	Started with IHSAEVNT - IHSATCFG Started with IHSAC000 --/etc/netview/trap_alert.conf	TALRTCFG startup parameter, global initialization file TALRTCFG statement
Message adapter configuration file name	Started with IHSAEVNT - IHSAMCFG Started with IHSAC000 --/etc/netview/message_adpt.conf	MSGCFG startup parameter, global initialization file MSGCFG statement
Event receiver configuration file name	Started with IHSAEVNT -- IHSAAECFG Started with IHSAC000 --/etc/netview/event_rcv.conf	ERCVCFG startup parameter, global initialization file ERCVCFG statement
Output log wrapping	0	OUTSIZE startup parameter
Secure mode operations	Non-secure	-S startup option
Disable console messages to OpenEdition® shell	Enabled	-P startup option
Console messages file name	Started with IHSAEVNT -- IHSAMSG1 Started with IHSAC000 -- /usr/lpp/netview/msg/C/ihsamsg1	-M startup option
Trace/error HFS path	/tmp	-E startup option
Trace settings	Off for all tasks	Global initialization file TRACE statement, TRACE command
Service startup	All services are started	Global initialization file NOSTART statement
Trace/error data logical destination	SYSOUT	Global initialization file OUTPUT statement, OUTPUT command
Tivoli Enterprise Console server IP locations	No default	Alert adapter and message adapter configuration file ServerLocation statement
Tivoli Enterprise Console server port numbers	0	Alert adapter and message adapter configuration file ServerPort statement

Alert adapter class definition statement (CDS) file name	Started with IHSAEVNT -- IHS AACDS Started with IHSAC000 -- /etc/netview/alert_adpt.cds	Alert adapter configuration file AdapterCdsFile statement
Alert-to-trap adapter class definition statement (CDS) file name	Started with IHSAEVNT -- IHSALCDS Started with IHSAC000 -- /etc/netview/alert_trap.cds	Alert-to-trap configuration file AdapterCdsFile statement
Trap-to-alert adapter class definition statement (CDS) file name	Started with IHSAEVNT -- IHSATCDS Started with IHSAC000 -- /etc/netview/trap_alert.cds	Trap-to-alert configuration file AdapterCdsFile statement
Event receiver class definition statement file name	Started with IHSAEVNT -- IHS AECDS Started with IHSAC000 -- /etc/netview/event_rcv.cds	Event receiver configuration file AdapterCdsFile statement
Message adapter format file name	Started with IHSAEVNT -- IHSAMFMT Started with IHSAC000 -- /etc/netview/message_adpt.fmt	Message adapter configuration file AdapterFmtFile statement
Maximum event cache size	64KB	Alert adapter and message adapter configuration file BufEvtMaxSize statement
Event cache HFS path	/etc/Tivoli/tec/cache	Alert adapter and message adapter configuration file BufEvtPath statement
Maximum event cache retrieval buffer size	64KB	Alert adapter and message adapter configuration file BufEvtRdblLen statement
Amount to shrink the event cache	8KB	Alert adapter and message adapter configuration file BufEvtShrinkSize statement
Enable event buffering	YES	Alert adapter and message adapter configuration file BufferEvents statement
Rate to flush the event cache	0	Alert adapter and message adapter configuration file BufferFlushRate
Maximum number of events allowed in the event cache	0	Alert adapter and message adapter configuration file BufferEventsLimit
Tivoli Enterprise Console server connection mode	connection_less	Alert adapter and message adapter configuration file ConnectionMode statement
Maximum size of a console event	4096 bytes	Alert adapter and message adapter configuration file EventMaxSize statement
Console event filtering definitions	No filters defined	Alert adapter and message adapter configuration file Filter statement

Console event filtering from event cache definitions	No filters defined	Alert adapter and message adapter configuration file FilterCache statement
Mode of console event filtering	OUT	Alert adapter and message adapter configuration file FilterMode statement
Broken connection retry interval	120 seconds	Alert adapter and message adapter configuration file RetryInterval statement
Console event forwarding debug mode	NO	Alert adapter and message adapter configuration file TestMode statement
Event receiver PPI name	NETVALRT	Event receiver configuration file NetViewAlertReceiver statement
Event receiver port number	0	Event receiver configuration file PortNumber statement
Enable PortMapper for the event receiver	YES	Event receiver configuration file UsePortmapper statement
Alert-to-trap SNMP agent IP location	loopback	Alert-to-trap service configuration file Hostname statement
Alert-to-trap community name	public	Alert-to-trap service configuration file Community statement
Alert-to-trap Enterprise Object ID	1.3.6.1.4.1.1.1588.1.3	Alert-to-trap service configuration file Enterpriseoid statement
Trap-to-alert PPI name	NETVALRT	Trap-to-alert service configuration file NetViewAlertReceiver statement
Trap-to-alert port number	162	Trap-to-alert service configuration file PortNumber statement

Customizing the Event/Automation Startup Parameters

Startup parameters can be specified for the IHSAEVNT startup procedure if you are starting the E/AS from the MVS system console, or on the UNIX System Services command line for the IHSAC000 command. Startup parameters follow two general formats:

```
parameter=value
-option[value]
```

Either format can be used from either startup environment unless otherwise noted below. However, in order to pass the option/value format to the IHSAEVNT startup procedure the list of options and values must be encoded into a single parameter/value format. The IHSAEVNT startup procedure provides the following parameter to accomplish this:

```
OELINE
```

An example of using the OELINE parameter to pass option/value format startup parameters to the IHSAEVNT startup procedure follows:

```
s IHSAEVNT,OELINE='-opt1 value1 -opt2 value2...'
```

Use single quotes to surround the options and values passed with the OELINE parameter.

The option/value format is a case-sensitive format. Ensure you specify the following options exactly as they are described. Values are not translated to uppercase. For some options, only the option is specified. There is no corresponding value associated with the option.

The startup parameters are:

INITFILE=*file* or -i *file*

This startup parameter specifies the name of the global initialization file in *file*. If you use the **INITFILE=*file*** format, the file is a 1–8 character PDS member name that is associated with the IHSSMP3 data set definition from the IHSAEVNT startup procedure. This format is not valid when starting the E/AS from the UNIX System Services command line. If you use the **-i *file*** format, the file is a full MVS data set or HFS path and file name. Surround MVS data set names with single quotes to make them fully-qualified data sets. For example:

```
INITFILE=IHSAINIT
-i 'NETVIEW.V5R1M0.SCNMUXCL(IHSAINIT) '
-i /etc/netview/global_init.conf
```

MSGCFG=*file* or -m *file*

This startup parameter specifies the name of the message adapter configuration file in *file*. If you use the **MSGCFG=*file*** format, the file is a 1–8 character PDS member name that is associated with the IHSSMP3 data set definition from the IHSAEVNT startup procedure. This format is not allowed when starting the E/AS from the UNIX System Services command line. If you use the **-m *file*** format, the file is a full MVS data set or HFS path and file name. Surround MVS data set names with single quotes to make them fully-qualified data sets. For example:

```
MSGCFG=IHSAACFG
-m 'NETVIEW.V5R1M0.SCNMUXCL(IHSAACFG) '
-m /etc/netview/message_adpt.conf
```

ALRTCFG=*file* or -a *file*

This startup parameter specifies the name of the alert adapter configuration file in *file*. If you use the **ALRTCFG=*file*** format, the file is a 1–8 character PDS member name that is associated with the IHSSMP3 data set definition from the IHSAEVNT startup procedure. This format is not allowed when starting the E/AS from the UNIX System Services command line. If you use the **-a *file*** format, the file is a full MVS data set or HFS path and file name. Surround MVS data set names with single quotes to make them fully-qualified data sets. For example:

```
ALRTCFG=IHSAACFG
-a 'NETVIEW.V5R1M0.SCNMUXCL(IHSAACFG) '
-a /etc/netview/alert_adpt.conf
```

ALRTTCFG=*file* or -a *file*

This startup parameter specifies the name of the alert-to-trap service configuration file in *file*. If you use the **ALRTTCFG=*file*** format, the file is a 1–8 character PDS member name that is associated with the IHSSMP3 data set definition from the IHSAEVNT startup procedure. This format is not allowed when starting the E/AS from the UNIX System Services command line. If you use the **-a *file*** format, the file is a full MVS data set or HFS path and file name. Surround MVS data set names with single quotes to make them fully-qualified data sets. For example:

```
ALRTTCFG=IHSAATCF
-l 'NETVIEW.V5R1M0.SCNMUXCL(IHSAATCF) '
-l /etc/netview/alert_trap.conf
```

TALRTCFCG=*file* or -t *file*

This startup parameter specifies the name of the trap-to-alert service configuration file in *file*. If you use the **TALRTCFCG=*file*** format, the file is a 1–8 character PDS member name that is associated with the IHSSMP3 data set definition from the IHSAEVNT startup procedure. This format is not allowed when starting the E/AS from the UNIX System Services command line. If you use the **-t *file*** format, the file is a full MVS data set or HFS path and file name. Surround MVS data set names with single quotes to make them fully-qualified data sets. For example:

```
TALRTCFCG=IHSATCFG
-t 'NETVIEW.V5R1M0.SCNMUXCL(IHSATCFG)'
-t /etc/netview/trap_alert.conf
```

ERCVCFCG=*file* or -e *file*

This startup parameter specifies the name of the event receiver configuration file in *file*. If you use the **ERCVCFCG=*file*** format, the file is a 1–8 character PDS member name that is associated with the IHSSMP3 data set definition from the IHSAEVNT startup procedure. This format is not allowed when starting the E/AS from the UNIX System Services command line. If you use the **-e *file*** format, the file is a full MVS data set or HFS path and file name. Surround MVS data set names with single quotes to make them fully-qualified data sets. For example:

```
ERCVCFCG=IHSACFCG
-e 'NETVIEW.V5R1M0.SCNMUXCL(IHSACFCG)'
-e /etc/netview/event_rcv.conf
```

PPI=*ppiname* or -p *ppiname*

This startup parameter specifies the name of the E/AS PPI mailbox in *ppiname*. For example:

```
PPI=IHSATEC
-p IHSATEC
```

OUTSIZE=*size* or -O *size*

This startup parameter enables output log wrapping and specifies the maximum size of the output log file, in kilobytes. If *size* is specified as 0, output log wrapping is disabled. For more information on E/AS output, refer to “Event/Automation Service Output” on page 118.

```
OUTSIZE=0
-O 0
```

-M *msgfile*

This startup parameter specifies the location of the E/AS messages file. *msgfile* specifies a full MVS dataset or HFS path and filename. Surround MVS data set names with single quotes to make them fully qualified data sets. For example:

```
-M 'NETVIEW.V5R1M0.SCNMUXMS(IHSAMSG1)'
-M /usr/lpp/netview/msg/C/ihsamsg1
```

-P This startup parameter is not allowed when starting the E/AS from the IHSAEVNT startup procedure. It is used to disable the forwarding of MVS system console messages to the UNIX System Services command shell if the E/AS was started under the UNIX System Services command shell. By default, a message that is issued to the MVS system console is also issued at the UNIX System Services command shell.

-S This startup parameter is not allowed when starting the E/AS from the IHSAEVNT startup procedure. This startup parameter specifies that the alert adapter service and message adapter service are to be started in

secure mode. For more information on secure mode, refer to “Running Event/Automation Service in Secure Mode” on page 122.

-E *path*

This startup parameter is not allowed when starting the E/AS from the IHSAEVNT startup procedure. This startup parameter specifies the HFS path of trace/error log files. *path* specifies an HFS path. For example:

-E /tmp

Customizing the Event/Automation Service Configuration Files

The E/AS uses six configuration files. These files and their default names are:

- The global initialization file
IHSAINIT or /etc/netview/global_init.conf
- The alert adapter configuration file
IHSAACFG or /etc/netview/alert_adpt.conf
- The alert-to-trap service configuration file
IHSAAATCF or /etc/netview/alert_trap.conf
- The trap-to-alert service configuration file
IHSATCFG or /etc/netview/trap_alert_trap.conf
- The message adapter configuration file
IHSAMCFG or /etc/netview/message_adpt.conf
- The event receiver configuration file
IHSAECFG or /etc/netview/event_rcv.conf

The global initialization file is used to change configurable settings that are required by all five services. Each of the other configuration files are used to change configurable settings that are specific to the services. The statements within these files must all be contained on one line. Each of these files can have comments. Comment statements begin with the pound sign (#).

If the E/AS is started from the IHSAEVNT startup procedure, by default the 8-character PDS name specified is used to locate the file. The file must be in a dataset specified by the IHSSMP3 dataset definition statement from the IHSAEVNT startup procedure. If the E/AS is started from the UNIX System Services command shell, by default the HFS name specified is used to locate the file.

Every statement in a configuration file can be a comment. If all configuration file statements are comments, the configuration file will not change any of the configurable settings. Each of the four configuration files **must** exist for the E/AS to properly initialize, even if the file contains nothing but comments. The E/AS will not initialize if it cannot locate a configuration file.

For more information on the configuration file statements, refer to the *Tivoli NetView for z/OS Administration Reference*.

Event/Automation Service Output

All event/automation service (E/AS) output can be sent to one or both of two destinations: the generalized trace facility (GTF) and the E/AS output logs. By default, data is sent to the E/AS output logs. The destination of E/AS output can be changed using the OUTPUT command or the OUTPUT statement in the global

initialization file. Refer to the *Tivoli NetView for z/OS Command Reference* and *Tivoli NetView for z/OS Administration Reference* for more information.

There is an output log associated with each of the three services, and an output log associated with the entire E/AS address space. If output log wrapping is disabled, these output logs are physically represented by one system file. If output log wrapping is enabled, these output logs are physically represented by two system files - a primary file and a secondary file.

When wrapping is disabled, all output log data is written to the primary file.

When wrapping is enabled, the wrap size is used to limit the total amount of bytes that can be written to either the primary or the secondary file. When this wrap size is exceeded, the current file being used for output log output (either the primary or secondary file) is closed, and the file that was not previously in use (either the primary or the secondary) is opened for further logging. Whenever an output log is opened, all data that was previously in the log is destroyed. Therefore, the maximum amount of output log data available is 2 times the wrap size (both the primary and secondary files are full), and the minimum amount of output log data available is the wrap size (a switch has just occurred to either the primary or secondary file, destroying all data previously in that file).

For more information on setting output log wrapping, refer to the OUTSIZE parameter on page 117.

Event/Automation Service Output Log Names

When the E/AS is started using the IHSAEVNT startup procedure, the names of the output logs are defined by the following data set definition statements within the IHSAEVNT procedure:

- IHSC (primary file) and IHSCS (secondary file) – defines the output log files for the E/AS address space.
- IHSA (primary file) and IHSAS (secondary file) – defines the output log files for the alert adapter service.
- IHSM (primary file) and IHSMS (secondary file) – defines the output log files for the message adapter service.
- IHSE (primary file) and IHSES (secondary file) – defines the output log files for the event receiver service.
- IHSL (primary file) and IHSLS (secondary file) – defines the output log files for an alert-to-trap service.
- IHST (primary file) and IHSTS (secondary file) – defines the output log files for a trap-to-alert service.

If output log wrapping is disabled, the data set definition for the secondary file need not be present in the IHSAEVNT startup procedure, but it is a good practice to leave it in. The data set definition for the primary file must always be present.

By default, the output log files are set to the IHSAEVNT jobs SYSOUT data set. If SYSOUT data sets are used for the output log files, output log wrapping is disabled. If you want to enable output log wrapping, you must change these data set definitions to reference an MVS sequential data set or HFS file.

Note: There is no restriction placed on the type of file that you specify in the data set definition statements in the IHSAEVNT startup procedure. However, it is recommended that you do not define a PDS member as an output log file

due to synchronization problems that may occur when trying to write data to the PDS member. You also should use a different file for each data set definition statement.

Unless you have been instructed to run with tracing enabled by a Tivoli service representative, it is recommended that you use the default SYSOUT data sets that are specified in the sample IHSAEVNT startup procedure and do not enable output log wrapping.

When the E/AS is started using IHSAC000 in the UNIX System Services command shell, the names of the output log files are defined as follows:

- The files must be HFS files. By default, the path of the files is /tmp. This path can be changed using the -E startup option. Refer to this option on page 118.
- controlp.log (primary file) and controls.log (secondary file) are the names of the output log files for the E/AS address space. These names cannot be changed.
- alertp.log (primary file) and alerts.log (secondary file) are the names of the output log files for the alert adapter service. These names cannot be changed.
- alrtrpp.log (primary file) and alrtrps.log (secondary file) are output error log files for the alert-to-trap adapter service.
- trapalrtp.log (primary file) and trapalrts.log (secondary file) are output error log files for the trap-to-alert service.
- messagep.log (primary file) and messages.log (secondary file) are the names of the output log files for the message adapter service. These names cannot be changed.
- eventrcvp.log (primary file) and eventrcvs.log (secondary file) are the names of the output log files for the event receiver service. These names cannot be changed.

The E/AS creates these output log files if they do not exist.

Note: Unless you have been instructed to run with tracing enabled by a Tivoli service representative, it is recommended that you do not enable output log wrapping.

Types of Event/Automation Service Output Data

The E/AS generates two types of output data: trace data and error data.

Trace data is only generated if tracing is enabled. By default, tracing is disabled. To change trace settings, refer to the *Tivoli NetView for z/OS Command Reference* for information on the TRACE command, and the *Tivoli NetView for z/OS Administration Reference* for information on the global initialization file TRACE statement.

In general, tracing should only be used if you are requested to do so by a Tivoli service representative.

Error data is composed of MVS system console messages and output log only messages. In general, any error condition detected by the E/AS results in an MVS console message. This console message is also written to E/AS output. To aid in problem determination, additional messages may also be written to E/AS output. These output log only messages that were not issued to the MVS system console may give more detail concerning the problem.

The combination of system console and output log only messages should allow you to resolve most E/AS problems without the aid of a Tivoli service representative.

Not all MVS console messages describe error conditions. There are a number of informational messages that are also issued by the E/AS and sent to E/AS output logs.

Format of Event/Automation Service Output Data

When an output log file is initially opened, the first entry in the output log file is composed of the name of the output file followed by a date/time string in the format:

```
day month date time year
```

The following example shows the header for the message adapter service primary output log file, assuming that the E/AS was started from the IHSAEVNT startup procedure:

```
IHSM Fri Feb 20 10:45:55 1998
```

All other E/AS output data is composed of a header followed by the specific data.

The header is composed of:

- A date/time string in the format:
day month date time year
- The module name of the module where the message was issued
- The line number within the module where the message was issued
- The type of message, which can be one of the following:
- LOW - Specifies this message is issued if the LOW or higher level of tracing has been enabled.
- NORMAL - Specifies this message is issued if the NORMAL or higher level of tracing has been enabled.
- VERBOSE - Specifies this message is issued if the VERBOSE level of tracing has been enabled.
- CONSMMSG - Specifies this is an MVS console message.
- LOGONLY - Specifies this is a message that accompanies an MVS console message, but is issued only to E/AS output.
- IP - Specifies this message is issued if IP tracing has been enabled.

An example of an E/AS output entry follows:

```
-----date/time-----      module line msgtype  -> specific data
|                         | | | | |
Fri Feb 20 10:45:55 1998  IHSAEAS0:2016 CONSMMSG:  IHS0075I Event/AutomationService started.
Subtask initialization is in progress for IHSATEC
```

In this example, the console message IHS0075I was issued from the reported E/AS module at the specified time and date.

Note: Module and line numbers are for use by a Tivoli service representative if additional problem determination is needed.

Customizing Alert and Message Routing from NetView

When NetView is installed, the routing of alert and message data to the event/automation service is by default disabled. NetView automation table statements and hardware monitor filter commands are used to enable the routing of alert and message data to the event/automation service. Refer to the *Tivoli NetView for z/OS Automation Guide* for complete information on enabling and customizing the routing of alerts and messages from NetView to the E/AS.

Running More Than One Event/Automation Service

Multiple E/AS address spaces can be active at the same time. In most cases, you will only need one E/AS; however, you may need more than one for any of the following reasons. You want:

- A subset of alerts or messages to be translated and sent to a different Tivoli Enterprise Console server.
- Alerts or messages to be translated and sent to more than one console server.
- A subset of console events to be translated and sent to a different NetView alert receiver.
- Console events to be translated and sent to more than one NetView alert receiver.

If you run more than one E/AS, the E/AS PPI mailbox name must be unique for each. All other configurable settings can be shared between the E/AS invocations. However, you should consider changing the following configurable settings between each E/AS invocation:

- If you use more than one event receiver service, only one should register with the PortMapper. Others should specify a port number and disable the use of PortMapper. If more than one event receiver attempts to use the PortMapper, only the last event receiver to access PortMapper will actually be registered; all other registrations for the other event receivers will be lost. A warning message is written to the MVS system console when the event receiver PortMapper registration is overwritten.
- The E/AS output log files should be unique for each E/AS invocation. Otherwise, data from one E/AS will be interleaved in the same output log file as data from another E/AS. If you are using the IHSAEVNT startup procedure to execute the E/AS, and the output log files are to SYSOUT data sets, then these datasets are automatically unique for each E/AS invocation.

Running Event/Automation Service in Secure Mode

The E/AS relies on the Tivoli client framework for secure mode operation. For more information, refer to the *Tivoli FrameWork Planning and Installation Guide*. For more information on events and secure mode operations, refer to *Event Integration Facility (EIF) User's Guide*.

Advanced Customization - Translating Data

In addition to the configuration files that the E/AS uses to define operational characteristics, each E/AS service uses a translation file that contains a set of rules that tell the service how to translate the incoming data into a Tivoli Enterprise Console event or a SNMP trap. Each translation file is a text-readable file that can be customized.

The translation files used by the services of the E/AS have two different formats. The alert adapter, alert-to-trap, trap-to-alert and event receiver services use a class definition statement (CDS) translation file. The message adapter service uses a message format translation file.

To customize these translation files, you should have an understanding of the format of console events, SNMP traps, or both. For more information about console events, refer to the *Tivoli Enterprise Console User's Guide*.

For additional information on SNMP traps, refer to the appropriate z/OS documentation for SNMP agent.

Class Definition Statement Files

The class definition statement (CDS) file defines how to construct Tivoli Enterprise Console events from the information that is sent by a data source. For the alert adapter service and the alert-to-trap service, the data source is NetView. For the event receiver service, the data source is a Tivoli Enterprise Console server. For the trap-to-alert service, the data source is an SNMP trap manager. The statements in this file are referred to as *class definition statements* (CDS's). Class definition statements are rules that enable the service to map the incoming data that it receives to a console event.

Note: The event receiver service, alert-to-trap service, and trap-to-alert service will further process the console event that is produced using these class definition statements to turn it into an alert or SNMP trap. Refer to "Event Receiver Post-CDS Processing" on page 140 for more information on creating alerts from console servers. Refer to "Alert-to-Trap Post-CDS Processing" on page 158 for more information on creating traps from alerts. Refer to "Trap-to-Alert Post-CDS Processing" on page 157 for more information on creating alerts from SNMP traps.

A CDS file is composed of one or more CDS's. Each CDS can include a **SELECT**, **FETCH** and a **MAP** segment that specify the rules for mapping data into a Tivoli Enterprise Console event. These rules allow for **selecting** an event class based on the incoming data, **fetching** additional data for creating the console event, and **mapping** the information collected from the incoming event into event attributes for the outgoing console event.

A CDS has the following general format:

```
CLASS <class_name> SELECT <select_statements> FETCH <fetch_statements> MAP
```

The CDS file also supports comment lines beginning with the comment sign (#).

The keywords in a CDS provide the following kinds of information:

CLASS

The *<class_name>* defines the class name that will be used on the outgoing console event if the incoming data matches this CDS.

SELECT

Consists of one or more *<select_statement>* entries that incoming data must satisfy to match, or select, this CDS. Select statements are evaluated in the order that they appear in the SELECT segment. If all of the *<select_statements>* of a particular CDS are satisfied, then the incoming data matches the corresponding CDS. Otherwise, the

adapter tries to match the incoming data with the next CDS. If the incoming data cannot be matched with any CDS, it is discarded.

FETCH

Consists of zero or more *<fetch_statement>* entries that are used to retrieve additional pieces of data from the incoming data in order to build the event attributes in the **map** segment. The FETCH segment is used to retrieve data not retrieved by the SELECT segment, or to change the data that was retrieved by the SELECT segment.

MAP Consists of zero or more *<map_statement>* entries that specify how to build the event attributes of the Tivoli Enterprise Console event instance using the service's default data, user-defined constant data and pieces of data retrieved in the SELECT and FETCH segments.

For the alert adapter service, each class of event defined in the **.baroc** file of the service on an event server must match one or more CDS in the CDS file. The CDSs specify how to map incoming data to the class and event attributes of the outgoing Tivoli Enterprise Console event instance. If you change or add classes or event attributes in the CDS file, you must make a corresponding change to the **.baroc** file on the event server.

For the event receiver service, the outgoing Tivoli Enterprise Console event is never sent to an event server; it is a pseudo-event that is processed further to create an alert. Therefore, there is no corresponding **.baroc** file on an event server for any Tivoli Enterprise Console events created from the event receiver's CDS file.

Each CDS is evaluated in the order it appears in the CDS file. An incoming event is mapped to the class specified by the first CDS whose SELECT segment is evaluated successfully. When more than one CDS is provided for a given class of event, the CDS with the most restrictive SELECT segment should appear first in the CDS file.

If the *<class_name>* is equal to ***DISCARD***, any incoming data matching the SELECT segment should be discarded. Note that data will also be discarded if it does not match any CDS. However, if a given type of incoming data must always be discarded, it is more efficient to define a ***DISCARD*** statement and put it at the beginning of the CDS file rather than letting the adapter evaluate all CDS's before finally discarding the event.

Encoding Incoming Event Data

Incoming event data is encoded by the service into name/value pairs. Name/value pairs are also referred to as *attributes*. For any incoming event, all of the attributes are placed in a list that is then used in the SELECT, FETCH and MAP segments. The service selects which, if not all, of the incoming data to encode into name/value pairs, see the specific service encoding discussion later in this section.

The name part of the attribute is a text string. There are two types of names - *generic* and *keyword*.

Generic names are text strings created by the services. A service may create these names internally, or it may create them from information provided in the incoming raw data; in either case, the method used by the service to create attribute names will be discussed with the specific service encoding later in this chapter.

Keywords have the format *\$keyword*. Data that is commonly provided in the incoming datastream to the service is usually coded into keywords rather than generic names. The actual keyword name is never derived from the incoming data, but rather is defined by the service.

The main difference between keywords and generic names is how the names are used in processing the CDS file. Keywords provide faster data lookup during CDS file processing. Otherwise, keywords and generic names are nothing more than data tags, with keywords prefaced with '\$'.

The value part of the attribute is also a text string. Again, the service will assign this text string based on data in the raw event.

Alert Adapter Service and Alert-to-Trap Service Data Encoding

The alert adapter and alert-to-trap service uses keyword attributes exclusively for their data encoding. The following table lists each of the keyword attribute names used and how the value field is assigned from the incoming alert data.

Attribute name	Description
\$ALERT_CDPT	A 2-byte hexadecimal value taken from the alert description code field of the generic alert data subvector, or the resolution description code field of the resolution data subvector.
\$ORIGIN	A character string with the name/type hierarchy pairs from the Hierarchy Name List or Hierarchy/Resource List subvectors. The string contains the hierarchy in the form: resnam1/typ1,resnam2/typ2,resnam3/typ3, resnam4/typ4,resnam5/typ5 Only the number of pairs in the actual subvector are used.
\$SUB_ORIGIN	A character string with the last pair in the name/type hierarchy pair list from the Hierarchy Name List or Hierarchy/Resource List subvectors. The string is in the form: resnamx/typx where <i>x</i> is the number of the last pair in the list.
\$HOSTNAME	The <i>netid.nau</i> node name of the SNA node where the alert originated. Could be a NetView/390 node, an AS/400® node, etc.
\$ADAPTER_HOST	The IP name of the host where the NetView/390 alert adapter resides.
\$DATE	The date when the alert was received by the NetView/390 alert adapter. In format: MMM HH:MM:SS, e.g. OCT 10 12:08:30.
\$SEVERITY	FATAL, CRITICAL, etc. The alert type field from the Generic Alert Data subvector, or the event type, is used to determine the severity. Refer to Table 18 on page 127.

\$MSG	The <i>Long Error Description:Long Probable Cause</i> message that describes the problem. This message is similar to the ALERT DESCRIPTION:PROBABLE CAUSE message displayed on the NPDA ALERTS-DYNAMIC panel.
\$ADAPTER_HOST_SNANODE	The <i>netid.domainid</i> node name of the NetView that sent the alert to the NetView/390 alert adapter.
\$EVENT_TYPE	E.g. PERMANENT, TEMPORARY, etc.. For Generic Alerts, it is obtained by inspecting the Alert Type byte of Generic Alert Data subvector. It matches the EVENT TYPE displayed on the NPDA EVENT DETAIL panel.
\$ARCH_TYPE	GENERIC_ALERT, GENERIC_RESOLUTION, or NONGENERIC_ALERT. NMVT Alert Major Vectors contain a Generic Alert Data subvector are GENERIC_ALERTs. NMVT Resolution Major Vectors are GENERIC_RESOLUTIONs. All other alerts are NONGENERIC_ALERTs.
\$PRODUCT_ID	The hardware or software product set identifier (PSID) of the alert or event sender. This can be 4, 5, 7, or 9 characters. Pertains to all generic alerts and some non-generic alerts.
\$ALERT_ID	An 8-character hexadecimal value assigned by the sender to designate an individual alert condition. The value will always be 00000000 for resolution alerts. Pertains only to generic alerts (including resolutions).
\$BLOCK_ID	The code used to identify the IBM hardware or software associated with the alert. See the <i>NetView Resource Alerts Reference</i> manual. Pertains only to non-generic alerts.
\$ACTION_CODE	A code that provides an index to predefined screens. Pertains only to non-generic alerts. For non-generic alerts, the combination of the block id and action code uniquely identify the sending product.
\$SELF_DEF_MSG	Text extracted from Self-defining Text Message Sv31.
\$EVENT_CORREL	Correlators extracted from MSU Correlation Sv47. These correlators correlate alerts to other alerts. That is, you may have two or more alerts that pertain to the same underlying problem and such alerts are correlated by Sv47. The <i>tecad_snaevent.rls</i> file on the Tivoli Enterprise Console server contains rules which discard alerts that have already been reported.

\$INCIDENT_CORREL	Correlators extracted from Incident Identification subvectors. These correlators correlate alerts to resolutions. The tecad_snaevent.rls file on the Tivoli Enterprise Console server contains rules which CLOSE all correlated alerts when a resolution is received.
\$ADAPTER_CORREL	A correlator that has meaning only to the alert adapter.
\$DETAILED_DATA	Always assigned the string "[N/A]".
\$CAUSES	Always assigned the string "[N/A]".
\$ACTIONS	Always assigned the string "[N/A]".

Non-keyword attributes can also be assigned by users in the NetView address space. Refer to *Tivoli NetView for z/OS Automation Guide* for more information on how to customize alerts forwarded from NetView. Using this method, any attribute name/value pair can be created and used by the CDS file process. The alert adapter and trap-to-alert service do not use generic attributes other than when they are assigned within NetView.

The value for the severity event attribute is determined by mapping an alert type (or event type) to a severity. The table below shows this mapping. The hexadecimal byte is the alert type field from the generic alert data subvector.

Table 18. Alert Types and Severities

Alert Type	Severity
0x01, PERMANENT	CRITICAL
0x02, TEMPORARY	HARMLESS
0x03, PERFORMANCE	WARNING
0x04, INTERVENTION REQ'D	CRITICAL
0xNN, CUSTOMER APPLICATION	MINOR
0xNN, END USER GENERATED	MINOR
0xNN, SUMMARY	HARMLESS
0xNN, INTENSIVE MODE REC	HARMLESS
0x09, AVAILABILITY	CRITICAL
0x0A, NOTIFICATION	WARNING
0x0B, ENVIRONMENT	CRITICAL
0x0C, INSTALLATION	WARNING
0x0D, OPERATION/PROCEDURE	WARNING
0x0E, SECURITY	CRITICAL
0x0F, DELAYED RECOVERED	WARNING
0x10, PERMANENT AFFECTED	MINOR
0x11, IMPENDING PROBLEM	WARNING
0x12, UNKNOWN	UNKNOWN
0xNN, HELD	MINOR
0x14, BYPASSED	WARNING
0x15, REDUNDANCY LOST	WARNING

Table 18. Alert Types and Severities (continued)

0x16, SITUATION	WARNING
0xNN, RESENT ALERT	MINOR
0xNN, RESOLVED PROBLEM	HARMLESS
0xNN, UNSUPPORTED TYPE	UNKNOWN

Alert-to-Trap Service Data Encoding

The alert-to-trap service constructs enterprise traps (type 6). The CDS file enables customization of the specific code field in the trap. This is done by supplying a value for the SPECIFIC keyword in the MAP sections of the CDS file.

The basic approach of the alert-to-trap service is to construct Tivoli Enterprise Console event keyword/value pairs from the alert and then map the keyword/value pairs (other than SPECIFIC) into SNMP OCTET strings to be included as variable bind data in the resulting trap. Both the keyword and the value are included in the resulting OCTET string.

The alert-to-trap service has access to the alert-adapters keyword attributes, and these can be used in SELECT, MAP and FETCH statements. However, not all alert adapter attributes are applicable to SNMP traps.

The CLASS names in class definition statements are not used in the traps built by the alert-to-trap service. However, the CLASS name is still required to satisfy CDS syntax rules, and it is useful when you document the trap you are constructing.

Trap-to-Alert Service Data Encoding

The trap-to-alert service receives an SNMP trap as its incoming data. This data is encoded into both keyword attributes and generic attributes.

The following table lists the keyword attributes created by the trap-to-alert service.

Attribute name	Description
\$ORIGIN_ADDR	The value is a string containing the internet address (in dotted decimal notation) from which the trap came. Note that when the sample datagram forwarding daemon is used, the value is the internet address of the host in which the daemon is running.
\$ORIGIN_PORT	The value is a string containing the number of the port (in decimal) at the origin address from which the trap came. Note that when the sample datagram forwarding daemon is used, the value is the number of the port over which the daemon forwarded the trap.
\$SNMP_VERSION	The value is a string containing the number (in decimal) indicating which SNMP version was implemented at the agent that sent the trap. This determines how the trap was formatted. The value for SNMPv1 is "0".

The following table lists the generic attributes created by the trap-to-alert service from the SNMP trap data that is not a variable binding. All data is converted to a

character string before assigning it to the generic attribute name.

Attribute name	Description
community	The value of the SNMP trap community field.
enterpriseOID	The value of the SNMP trap enterpriseOID field.
agent_address	The value of the SNMP trap agent address field.
generic_trap	The value of the SNMP trap generic trap field.
specific_trap	The value of the SNMP trap specific trap field.
timestamp	The value of the SNMP trap timestamp field.

The variable binding data is created directly from the variable binding data. The variable binding name becomes the name of the generic attribute, and the variable binding data is converted to a character string if it is not already a character string and assigned to the generic attribute. When more than one variable binding within an SMMP trap contains the same name, the name and index is appended to the name to create the generic attribute name. For example, if the variable binding name

```
1.3.6.1.4.1.2.2.1.3.1.0
```

occurred 3 times within the same SNMP trap, the generic attribute names that are created as a result would be as follows:

```
1.3.6.1.4.1.2.2.1.3.1.0
1.3.6.1.4.1.2.2.1.3.1.0<1>
1.3.6.1.4.1.2.2.1.3.1.0<2>
```

Event Receiver Service Data Encoding

The event receiver service receives a Tivoli Enterprise Console event as its incoming data. This data is encoded into both keyword attributes and generic attributes. This encoding is very straightforward since the data is already in the name/value form of an attribute. Every event attribute name in the incoming console event becomes the name of a generic attribute in the attribute list, and the corresponding event attribute value becomes the value of the attribute. The className of the event is encoded as the value of the \$CLASSNAME keyword attribute. As such, the event receiver creates one keyword attribute, \$CLASSNAME, and as many generic attributes as there are event attribute/value pairs in the incoming console event.

SELECT Segment of a Class Definition Statement

The SELECT segment of a CDS is composed of one or more `<select_statement>` entries. Each `<select_statement>` entry has the following format:

```
<n>: ATTR(<a_op>, <a_op_value>),
      VALUE(<v_op>, <v_op_value>);
```

A `<select_statement>` is satisfied if an attribute is found in the list of attributes provided by the service that fulfills the conditions specified by the **ATTR** and **VALUE** expressions of the `<select_statement>`. An attribute must be found for each

<select_statement> for the SELECT segment to be satisfied. If a SELECT segment is not satisfied, the entire CDS is ignored and processing continues with the next CDS in the CDS file.

<n> Is the identification number of the *<select_statement>*. *n* can be any valid integer. Each *<select_statement>* must have a unique identification number; this identification number is used in further processing of the CDS.

ATTR

Specifies the name of an attribute, in *<a_op_value>* and a modifying condition on the attribute name in *<a_op>*. The **ATTR** expression is mandatory in the SELECT statement. The list of attributes created by the service from the incoming data are searched until an attribute is found that has a name field which matches the condition expressed by the **ATTR** expression.

<a_op>

Modifies the **ATTR** name and can have one of the following values:

= Specifies that the attribute name in *<a_op_value>* must match the name of an attribute in the attribute list.

PREFIX

Specifies that the attribute name in *<a_op_value>* must be a prefix of the name of an attribute in the attribute list.

SUFFIX

Specifies that the attribute name in *<a_op_value>* must be a suffix of the name of an attribute in the attribute list.

<a_op_value>

Specifies the name of an attribute. The attribute list is searched sequentially and the **ATTR** *<a_op>* expression is applied to each attribute name field until a matching attribute is found.

By default, *<a_op_value>* is a string. However, *<a_op_value>* can also be a variable. Variables are described below.

When specified as a string, *<a_op_value>* must be enclosed in double quotes (") if the string contains a blank character or if it is all digits (0 through 9). The following examples show possible *<a_op_value>* strings:

```
hello
$ORIGIN
"hello, world"
"12"
```

When specified as a variable, *<a_op_value>* can contain any of these types of variables:

Keyword

A keyword provided by the event adapter, for example, \$ORIGIN.

Name Name variables are assigned the value of the name field of an attribute that has satisfied a previous *<select_statement>***ATTR** expression. A name variable is specified as \$*Nn*, where *n* is the number of the *<select_statement>* that the desired attribute satisfied (for example, \$N2).

Value Value variables are assigned the value of the value field of an attribute that has satisfied a previous *<select_statement>* **VALUE**

expression. A value variable is specified as $\$Vn$, where n is the number of the `<select_statement>` that the desired attribute satisfied (for example, $\$V5$).

The following example of an **ATTR** expression looks for a generic name that is equal to **user1**. If the service has provided an attribute named **user1**, the **ATTR** expression will be satisfied.

```
ATTR(=,"user1")
```

The following example of an **ATTR** expression looks for a keyword that is equal to **\$ORIGIN**. If the service has provided an attribute named **\$ORIGIN**, the **ATTR** expression will be satisfied.

```
ATTR(=,$ORIGIN)
```

VALUE

This expression is optional. For the attribute in the attribute list that matches the associated **ATTR** expression, the value of the attribute is subjected to a match based on the information in the **VALUE** expression.

<v_op>

Modifies the **VALUE** expression and can have one of the following values:

= Specifies that the **VALUE** expression in `<v_op_value>` must match the value of an attribute in the attribute list.

PREFIX

Specifies that the **VALUE** expression in `<v_op_value>` must be a prefix of the value of an attribute in the attribute list.

SUFFIX

Specifies that the **VALUE** expression in `<v_op_value>` must be a suffix of the value of an attribute in the attribute list.

!= Specifies that the **VALUE** expression in `<v_op_value>` must **not** be equal to the value of an attribute in the attribute list.

<v_op_value>

Specifies the value of an attribute. By default, `<v_op_value>` is a string. However, `<v_op_value>` can also be a variable.

When specified as a string, `<v_op_value>` must be enclosed in double quotes (") if the string contains a blank character or if it is all digits (0 through 9). The following examples show possible `<v_op_value>` strings:

```
hello
$ORIGIN
"hello, world"
"12"
```

When specified as a variable, `<v_op_value>` can contain any of these types of variables:

Keyword

The keyword is assigned a constant value (either a string or a number), and the keyword can be used to reference the value.

Name Name variables are assigned the value of the name field of an attribute that has satisfied a previous `<select_statement>` **ATTR** expression. A name variable is specified as $\$Nn$, where n is the number of the `<select_statement>` that the desired attribute satisfied (for example, $\$N2$).

Value Value variables are assigned the value of the value field for an attribute that has satisfied a previous *<select_statement>* **VALUE** expression. A value variable is specified as \$Vn, where n is the number of the *<select_statement>* that the desired attribute satisfied (for example, \$V5).

The following example of a **VALUE** expression looks for an attribute with a value that is prefixed with **Serial**:

```
VALUE(PREFIX,"Serial")
```

A valid match for this **VALUE** expression is **Serial1**.

SELECT Segment Evaluation

For an entire SELECT segment to be matched, an attribute must be matched for each of the *<select_statement>* expressions in that SELECT segment. More than one attribute in the attribute list may satisfy a *<select_statement>*. The first one in the attribute list that satisfies the statement is used for further CDS processing.

If the SELECT segment is satisfied, the class name of the SELECT segment is used for the outgoing Tivoli Enterprise Console event. Processing of the event continues with the FETCH segment, unless the class is ***DISCARD***, in which case the event is discarded. If the incoming data satisfies no SELECT segment of a CDS in the CDS file, the incoming data is discarded.

Each time a *<select_statement>* is evaluated successfully, the two variables \$Nn and \$Vn are created. These variables, along with the adapter-provided keywords, can be used in any subsequent SELECT, FETCH or MAP segment.

FETCH Segment of a Class Definition Statement

The SELECT segment of a CDS retrieves attribute names and values from the incoming data, but it does not allow for changes to the selected pieces of information. In some circumstances, it is necessary to extract a substring out of an attribute value or to provide user-defined variables. The FETCH segment in a CDS allows you to do this.

The FETCH segment is composed of one or more *<fetch_statement>* expressions. Each *<fetch_statement>* has the following format:

```
<n>: <expression>
```

where

<n> Is an identification number of the *<fetch_statement>*. *<n>* can be any valid integer. Each *<fetch_statement>* must have a unique identification number. A *<fetch_statement>* results in the value of *<expression>* being assigned to a new variable, \$Fn, where n is the identification number of the *<fetch_statement>*.

<expression>

Is one of the following:

- A string
- Any output value from the SELECT segment (such as adapter-provided keywords and SELECT segment variables.
- Any output from a previous *<fetch_statement>*
- A substring with any combination of strings, SELECT segment output, and *<fetch_statement>* output.

An example of a FETCH segment using substrings is:

```
1: SUBST ($V2, 1, 5);
```

This statement uses the value of the variable \$V2, as assigned from *<select_statement>* number 2, and assigns the substring represented by the first 4 characters of \$V2 to the variable \$F1.

The output of the FETCH segment is the set of fetch variables \$Fn.

MAP Segment of a Class Definition Statement

The MAP segment of a CDS creates the event attributes and associated values that will be put in the outgoing Tivoli Enterprise Console event.

The MAP segment is composed of one or more *<map_statement>* expressions. Each *<map_statement>* has one of the following formats:

```
<slot name> = <string>;  
<slot name> = <variable>;  
<slot name> = PRINTF(<format_string>, <var1>, ..., <varn>);
```

<slot_name>

The name of any event attribute. For the alert adapter service, this should be an event attribute that corresponds to an event attribute in the service's **.baroc** file on an event server. For the event receiver service, this should be an event attribute that is allowed by the event receivers post-CDS file processing.

<string>

Any character string.

<variable>

Any variable passed to the MAP segment from the SELECT or FETCH segments, such as adapter-defined keywords or segment variables.

PRINTF

Specifies a format that allows the value of the event attribute to be formatted using a C-style **printf()** format string. This format string currently supports only the **%s** format specifier.

<var> Can contain either a *<string>* or a *<variable>*.

Here is an example of a MAP segment:

```
MAP  
  origin = $V2;  
  hostname = $HOSTNAME;  
  msg = PRINTF("The origin is %s", $V2);
```

In this example, the **origin** event attribute would be given the value of the SELECT segment variable \$V2. The **hostname** event attribute would be given the value of the \$HOSTNAME keyword. Assuming the value of the variable \$V2 is **NV390SP/SP**, the **msg** event attribute would be given the value **"The origin is NV390SP/SP"** (the double quotes are not included in the value).

The output of the map process is a list of event attribute name/value pairs that are used to generate the outgoing Tivoli Enterprise Console event that will either be sent to the event server or used for post CDS-file processing.

MAP_DEFAULT Section of the Class Definition Statement Files

Some event attributes, like source and hostname, will probably have a constant value for all the Tivoli Enterprise Console events generated by a given service. To avoid repeating identical map statements in many CDS's, the CDS file supports a MAP_DEFAULT section. This section defines event attribute name/value pairs for all CDS's in the CDS file. The event attributes that are defined in this global definition section can be overridden by specific definitions in a CDS.

Here is an example of a MAP_DEFAULT section:

```
MAP_DEFAULT
  origin = $ORIGIN;
  sub_origin = $SUB_ORIGIN;
  msg = $MSG;
END
```

In some cases, you may want to put CDSs into more than one CDS file and have them all be used by a service. To enable this, an extension to normal CDS file processing has been added for the E/AS services. The %INCLUDE statement allows additional CDS files to be embedded within the current CDS file. The %INCLUDE keyword cannot be preceded by blank characters, and it must be followed by a separator of one blank character. Following the separator is the file name of the CDS file to be opened. This file name is either a 1 to 8 character PDS member name that is associated with the IHSSMP3 data set definition, or a complete file name that is preceded by the backslash ('\') character. The maximum number of CDS file members that can be opened at the same time is 20; this represents the maximum number of nested %INCLUDE statements that are valid.

The following example shows the %INCLUDE statement syntax. Assume that the file named IHSAACD1 contains the single statement:

```
sub_origin = $SUB_ORIGIN;
```

in this example:

```
MAP_DEFAULT                                     //Statements from IHSAACDS
  source = NV390ALT;
  origin = $ORIGIN;
%INCLUDE IHSAACD1                               //New file with sub_origin statement
  hostname = $HOSTNAME;                         //Continuation of IHSAACDS
  adapter_host = $ADAPTER_HOST;
END
```

For more information about Tivoli Enterprise Console events, refer to the *Tivoli Enterprise Console Adapter's Guide*. For an example of using CDS's, refer to the IHSAACDS or IHSAECDS sample shipped with the event/automation service. These are the default translation files used for the alert adapter and event receiver services, respectively.

Message Format Files

The FMT file defines how the message adapter service constructs Tivoli Enterprise Console events from message information that is sent by NetView. The statements in this file are referred to as format specification statements (FSS). Format specification statements are rules that allow the service to map the incoming message data that it collects from NetView to an outgoing console event.

The following sections describe the syntax of the message adapter service's format specifications and how format specifications are mapped into events.

Encoding Incoming Event Data

For the message adapter service, the incoming data is a message string. This message text string is matched against *format specifications* in the FMT file. The primary piece of information, therefore, is the message string itself.

Like a CDS file, the job of the FMT file is to allow the user to customize the outgoing console event based on the incoming message data. This method does not encode the data into attributes; however, there are certain event attribute names that receive default information from the incoming message data.

The table below lists each of the default event attribute names and their corresponding default values. If the value for the event attribute is not actually present in the incoming data, then the default event attribute value will be the null string. ANY event attribute that is listed in the map rules portion of a format specification statement has a default value; if it is not provided in the incoming data, its default value is the null string ("").

Event attribute name	Description
origin	The <i>netid.domainid</i> node name of the NetView where the message originated.
sub_origin	The job number associated with the message. If a job number is not available for the message, the value defaults to a null string ("").
hostname	Same as the origin event attribute.
adapter_host	The IP name of the host where the Event/Automation Service is running.
date	The date and time that the message was sent from the NetView automation table. In format: MMM HH:MM:SS, e.g. OCT 10 12:08:30.
msg_id	The first token of the message. In most cases, this token is the actual message identifier.
severity	Inferred from the last character of the msg_id. The translation of this character to a value for this event attribute is: A, E, S CRITICAL T FATAL anything else WARNING
msg	The message text, which includes msg_id as the first token.
adapter_host_snanode	The <i>netid.domainid</i> node name of the NetView that sent the message to the Message Adapter service.
multiline_msg	The second and succeeding message lines from the message. If the message is contained in one line, the value of multi_line message is N/A .
jobname	The jobname associated with the message. If a jobname is not available for the message, the value of jobname defaults to a null string ("").

Default event attributes and values can also be assigned by users in the NetView address space. Refer to the *Tivoli NetView for z/OS Automation Guide* for more information about customizing messages forwarded from NetView. Using this method, any attribute name/value pair can be created and used by the FMT file process.

Format Specifications

The FMT file is made up of 1 or more FSS. An FSS has the following three parts:

- The format header has the keyword **FORMAT** followed by the class name. This is optionally followed by the **FOLLOWS** keyword and a previously defined **FORMAT** class name. If the incoming message matches this FSS, the class name following the **FORMAT** keyword will be used on the outgoing Tivoli Enterprise Console event.
- The format content has a format string optionally followed by a list of map rules. The format string performs a function similar to the **SELECT** segment of a CDS file; that is, it matches the incoming message to a particular FSS. The map rules perform a function similar to the **MAP** segment in the CDS file; that is, they assign values to event attributes.
- The **END** keyword completes the FSS.

The format header, the format string, each map rule, and the **END** keyword must begin on a new line.

The **FOLLOWS** relationship is used to enable a specific FSS to be built from more generic ones. When format B follows format A, B inherits all of the map rules (but not the format string) from A. Format B can define any additional map rules, but any map rules redefined by B are *not* inherited from A. Format B can override inherited map rules by redefining them.

Messages that are forwarded by NetView typically have a common format consisting of a message identifier and message-specific text. These message components can be represented in the format string using a component specifier notation that is very similar to the C-style **printf()** notation. This **printf()** notation is similar to the notation used in CDS files.

The following format string describes the entire class of messages that are produced by the NetView automation table:

```
%s*
```

Input messages are tokenized into constants and blanks. A constant is any consecutive string of non-blank characters. Component specifiers allow the constants and blanks to be grouped into more complex "tokens" when trying to match an FSS against a specific message. The current allowable component specifiers are:

```
%s Matches one constant in the input message  
%s* Matches zero or more constants in the input message  
%s+ Matches one or more constants in the input message
```

The format string **DSI%s %s*** is taken from the default message adapter FMT file shipped with the E/AS, and is used in the following discussion to demonstrate the usage of format strings.

As an example of matching a message to the **DSI%s %s*** format specification, consider the following NetView message:

```
DSI002I INVALID COMMAND: 'BADCOMMAND'
```

The component specifiers and matches are as follows:

```
DSI DSI
%s 002I
%s* INVALID COMMAND: 'BADCOMMAND'
```

The DSI002I message has some constant parts and some variable parts. That is, certain parts of the message (constant parts) will be the same for any DSI002I message that is generated. The constant parts of the message are:

```
DSI002I INVALID COMMAND: ' '
```

The variable part of the message is:

```
BADCOMMAND
```

Note that the first constant part of the message goes all the way to the first single quote (') in the message. The second single quote is the beginning of the second constant part of the message, which also happens to be the last character in the message. The data inside of the single quotes is all variable.

The following message is an example of another DSI002I message with different variable parts:

```
DSI002I INVALID COMMAND: 'WORSE COMMAND'
```

In this case, the variable part is composed of two words and a space -- WORSE COMMAND.

The format string **DSI%s %s*** can be specialized for the DSI002I message as follows:

```
DSI %s INVALID COMMAND: '%s*'
```

Using the DSI002I message above, the component specifiers and matches are as follows:

```
DSI DSI
%s 002I
INVALID COMMAND: 'INVALID COMMAND: '
%s* WORSE COMMAND
' '
```

The blank characters that separate the words of a message must also be present in the format string. A single space character in the format string will match any number of blank characters in the message.

Suppose the space between the colon (:) and the quote (') is deleted in the specialized DSI002I format string given above:

```
DSI %s INVALID COMMAND: '%s*'
```

In this example, the format string would no longer match DSI002I messages. However, in the following example, the NetView message **would** match the format specification, since all consecutive blanks from both the input message and the format specification are boiled down to a single blank character:

```
DSI %s INVALID COMMAND: '%s*'
```

Care should be taken when using arbitrary length repeater component specifiers (**%s*** and **%s+**). The following format string does not make much sense:

```
This is not a good format %s* %s*
```

The first %s* will match everything through the end of the message, and the second %s* will never match anything. It may appear that this does not matter, but the importance becomes apparent when map rules are discussed in “Map Rules”.

The following format string, however, is meaningful:

```
This is a good format %s* : %s*
```

The first %s* will match everything up to the first colon (:), and the second %s* will match everything through the end of the message.

From the above examples, you can see that you can specialize a generic format to match a more specific event by either replacing component specifiers with constants or by restricting the arbitrary length repeater specifiers to a fixed length by using constants to terminate the specifier.

Map Rules

The service translates incoming message data into an event class with event attribute name/value pairs, and sends this information to an event server. As with the alert adapter service, a **.baroc** file at the event server must be present to match the outgoing Tivoli Enterprise Console events created by the message adapter service.

The event class is determined by matching an input message to an FSS as described previously. However, once the class is determined. Values must be assigned to the event attribute names. These values can come from a variety of places, such as from the message itself, from default event attributes provided by the service, or from specifications within the FMT file. Map rules define how event attributes are assigned values.

The map rule portion of the format string consists of zero or more lines that contain a **.baroc** file event attribute name followed by a value specifier. The value specifiers are one of four types:

- $\$i$, where i indicates the position of a component specifier in a format string. Each component specifier is numbered from 1 to the maximum number of component specifiers in the format string. For example, in the specialized format specification for the DSI002I message given above, the %s* component specifier would be referred to in the map rules as **\$2**. The value of a $\$i$ value specifier, also referred to as a *variable* value specifier, is the portion of the input message that was consumed by the component specifier. These variables are very similar to the variables output from the SELECT and FETCH segments in the CDS file.
- A constant string. The value of the event attribute is the specified string. If the string is a single constant, it can be specified without surrounding double quotes ("). Otherwise, double quotes must be used.
- A **PRINTF** statement. This mechanism allows you to compose more complex event attributes from other event attributes. The **PRINTF** statement consists of the keyword **PRINTF** followed by a C-style **printf()** format string and a list of event attribute names. The **printf()** format string currently only supports the %s conversion specifier. The values of the event attributes that are used in the **PRINTF** statement must also have been derived from either the $\$i$ value specification or a constant string value specification. They cannot be derived from another **PRINTF** value specification. The value of the argument event attributes will be used to compose a new constant string according to the

printf() format string. This constant string becomes the value of the event attribute. This value specifier is very similar to the **PRINTF** MAP segment format in the CDS file.

- **DEFAULT.** This keyword indicates that the adapter should use its internal logic to derive the value of the indicated event attribute. For example, the incoming message data contains the hostname (netid.nau) where the message originated. If the hostname event attribute is therefore set to the value **DEFAULT**, netid.nau will be the value of the hostname event attribute. This is similar to the use of keywords in the alert adapter service.

Since **DEFAULT** is a keyword, a constant map whose value is the string **DEFAULT** must be specified in double quotes ("").

You should specify only one map rule for each **.baroc** file event attribute in any one format specification. The map rule can be inherited from a more generic format specification (using the **FOLLOWS** keyword), or it can be explicitly defined on the format specification that directly matches the input message. Since the service does not have access to the **.baroc** file, which resides on the event server, care must be taken to make sure that the format specifications agree with the corresponding **.baroc** file definitions. If an event attribute name is misspelled in a map rule, for example, the service will not report any error and will send the event to the event server as usual. However, the event will be meaningless to the event server.

There can be attributes in the incoming message that do not directly correspond to any **.baroc** file event attributes. However, the service might need to use these values to compose **PRINTF** style constant strings. This data needs to be assigned to temporary event attributes, which can then be used in the **PRINTF** value specification but does *not* allow the event attribute to be sent over to the event server as an independent event attribute name/event attribute value pair. Temporary event attributes are designated with a minus sign (-) immediately preceding the event attribute name in the map rule. These temporary event attributes are not **.baroc** file event attributes. Do not use the minus sign (-) when referring to the temporary event attribute in the **PRINTF** specification.

%INCLUDE Statements

The **%INCLUDE** statement allows additional FMT files to be imbedded within the current FMT file. The **%INCLUDE** keyword cannot be preceded by blank characters, and it must be followed by a separator of one blank character. Following the separator is the file name of the FMT file to be opened. This file name is either a 1 to 8 character PDS member name that is associated with the IHSSMP3 dataset definition, or a complete file name that is preceded by the backslash ('\') character. The maximum number of FMT file members that can be opened at the same time is 20; this represents the maximum number of nested **%INCLUDE** statements that are allowed.

Format File Example

The following sample will be used to demonstrate the concepts discussed above; this example was taken (and modified somewhat) from the message adapter services default message format file (IHSAMFMT):

```
FORMAT NV390MSG_Event
%S*
source NV390MSG
origin DEFAULT
desctext "This string will be overridden"
END
```

```

FORMAT NV390MSG_NetView_NCCF FOLLOWS NV390MSG_Event
DSI%s %s*
sub_source "NetView NCCF"
msgnumber $1
temp1 $2
desctext PRINTF("Got a DSI message: %s", temp1)
END

%INCLUDE MOREFMTS

```

Using this format file, assume that the following message is received by the service:

```
DSI002I INVALID COMMAND: 'A BAD COMMAND'
```

This message will match the NV390MSG_NetView_NCCF format specification defined above IF the additional format statements include in MOREFMTS do not specify another format specification that this message can match on. Remember, matches on the FSS in the FMT file begin with the **last** FSS in the file and progress toward the first FSS until a match occurs.

With this match, the source event attribute will be assigned the string value NV390MSG. The origin event attribute will be assigned whatever default the event adapter associates with this event attribute. The desctext event attribute will be assigned the string This string will be overridden initially. These event attributes are all assigned with the more generic NV390MSG_Event FSS, from which the NV390MSG_NetView_NCCF FSS follows.

The sub_source event attribute will be assigned the value of NetView NCCF. The msgnumber event attribute will be assigned the value 002I (which was dissected from the input message on the first %s* specification). The -temp1 temporary event attribute will be assigned the string INVALID COMMAND: 'A BAD COMMAND' (which was dissected from the input message on the second %s* specification). This temporary variable is then used with the **PRINTF** value specifier to override the desctext event attribute with the string Got a DSI message: INVALID COMMAND: 'A BAD COMMAND'.

All of the event attributes, with the exception of the -temp1 event attribute, will be used to build the outgoing Tivoli Enterprise Console event. The classname for the event will be NV390MSG_NetView_NCCF, the name of the most specifically matched FSS.

For more information about Tivoli Enterprise Console events, refer to the *Tivoli Enterprise Console Adapter's Guide*. For an example of using FSS, refer to the IHSAMFMT sample shipped with the event/automation service.

Event Receiver Post-CDS Processing

For the alert adapter service and message adapter service, translation files are used to translate incoming service specific data into a Tivoli Enterprise Console event. For the event receiver, a CDS file will be used to go in the opposite direction (translate an event into a NetView alert).

To do this, the processing of the CDS file by the event receiver will be modified slightly from the processing that is done on the file by the alert adapter service. Syntactically, all of the information that is discussed in "Class Definition Statement Files" section above is still true for the event receiver CDS file. The event receiver treats the event that is output by the CDS file process as a pseudo event; that is,

the event is not meant to be sent to a Tivoli Enterprise Console server, but rather is parsed for certain specific event attributes that are encoded into the NMVT.

The Input Attribute List

The incoming Tivoli Enterprise Console event is encoded into an attribute list as described in the service specific encoding section later in this chapter. In addition to the **\$CLASSNAME** keyword created when the incoming event is parsed, there are additional keywords created for the input attribute list by the event receiver. The following list describes the additional keywords:

Keyword	Description	Default
\$NMVT_TYPE	The type of the NMVT to be created (alert or resolution). This keyword is modified by the NMVT_TYPE event attribute. The NMVT_TYPE event attribute can have a value of ALERT or RESOLVE.	ALERT
\$CDS_GROUP	This keyword contains values in the set "GROUP001", GROUP002", ... "GROUP999". The value of the CONTINUE event attribute is used to set the value of this keyword. For more information on the \$CDS_GROUP keyword and the CONTINUE event attribute, see the section "Matching Multiple CDS's to Create the Pseudo Event" later in this chapter.	GROUP001
\$BUILD_SV31LIST	Assigned the value of the BUILD_SV31LIST event attribute. This event attribute can have a value of NO or YES. When the alert is built, the value of this keyword is used to determine whether subvector 31s are to be added for each event attribute/value pair in the original Tivoli Enterprise Console event. For more information about the \$BUILD_SV31LIST keyword and the BUILD_SV31LIST event attribute, see the section "Building the SV 31s containing the Original Event" later in this section.	YES

The Output Pseudo Event

Like any Tivoli Enterprise Console event, this pseudo event contains a class name, followed by event attribute/value pairs. Note that because this event will never be

sent to a console, there is no `.baroc` file on any console server that corresponds to these events. In general, a CDS file enables any event attribute/value pair and any class name to be put into the pseudo event. Even though any class name and event attribute/value pair can be placed in the pseudo event, the event receiver only uses certain predefined event attribute names to translate the event into an alert. Any other event attributes are ignored.

The Pseudo Event Class name

The event receiver does not use the pseudo event class name for translating the Tivoli Enterprise Console event. All of the CDSs in the event receiver CDS file *can* have the same name; however, for ease of organizing the various CDSs and debugging, it is recommended that you use a different class name for each CDS in the CDS file. The convention used in the sample CDS file shipped with the E/AS is to group the CDSs that are associated with producing a particular subvector within the NMVT together and prefacing them with a common character string. The end of the class name can then have some unique designation to make it unique.

An example:

```
CLASS SV05_1
...
END
CLASS SV05_2
...
END

CLASS SV05_3
...
END

...
```

In this example, the `SELECT` segments (not shown) in each CDS statement will cause a different subvector 05 to be built. The class name for the SV 05 that is eventually built will have a unique name that identifies it as an SV 05. Again, this information is only used only for visual organization and debugging.

The NMVT_TYPE event attribute

You can specify the type of NMVT, whether it is an alert or a resolution, by coding the `NMVT_TYPE` event attribute in the `MAP` segment of a CDS. There are two valid values for this event attribute: **RESOLVE** and **ALERT**. The value of this event attribute is copied to the `$NMVT_TYPE` keyword.

The SV event attribute

This event attribute is the main vehicle for creating the subvectors that are to be placed into the NMVT.

The event attribute name must be prefixed with `SV`; the rest of the event attribute name can be any character string. `SV05`, `SVAA` and `SVNONSENSE` are all recognized as **SV** event attributes. Again, for clarity and debugging, it is recommended that the event attribute names contain the number of the subvector being created -- `SV05`, `SV92`, `SV05_1`.

An `SV` event attribute value contains the full subvector (including the length and subvector key). The values that are assigned to `SV` event attributes in the `MAP` segment of a CDS are interpreted as character strings; the event receiver will

decode the numeric character string into the hexadecimal values that are to be used in the alert. An example of a subvector event attribute from the sample CDS file:

```
SV05 = "0B0509100004E3C5C30040";
```

The value in the SV05 is a character string with hexadecimal characters. The event receiver translates this character string into true numeric format for inclusion in the NMVT. The event receiver does not validate this subvector. The subvector that is placed into the NMVT is similar to the following:

```
0B0509100004E3C5C30040
```

Following the general CDS file syntax, if the event attribute value contains only the digits in the range of 0–9, the value must be enclosed within double quotations to be interpreted as a string. The previous example has alphabetic characters (representing the hexadecimal values A-F) in it, so it was not necessary to enclose the event attribute value within quotes. It is a good habit, though, to enclose SV event attributes within double quotations.

Disabling Hexadecimal String Translation

In some cases, you may want to add a character string that is **not** a hexadecimal value to the subvector string. As previously described, by default the event receiver attempts to translate the event attribute value hexadecimal string into numeric format under the assumption that the string is a sequence of hexadecimal characters (0–9, A–F). In the previous example, the hexadecimal string E3C5C3 is, in EBCDIC, TEC.

To specify the string TEC directly within the event attribute value, enclose the string within <> braces. The braces must have escape characters preceding them; the escape character is # . Using this convention, for example, the string is as follows:

```
SV05 = "0B0509100004#<TEC#>0040"
```

This event attribute value would produce exactly the same NMVT subvector as the first example, as follows:

```
0B0509100004E3C5C30040
```

The braces indicate to the event receiver that the data enclosed within the braces is **not** a hexadecimal string number that needs to be converted, but the string is to be placed directly into the NMVT.

Using Attribute List Data in the Output Subvector

Event attributes can be assigned the value of a CDS variable (\$V, \$N, \$F variables), the value of a keyword, or generic attribute from the attribute list. When using these variables, it is likely that the value of the variable should not be converted. Also, it is likely that these variables do not contain the entire coded subvector entirely within the variable. To handle this, the **PRINTF** style of MAP statement assignment is useful.

Extending the SV 05 example introduced above, assume that the string TEC is the value of the \$V2 variable generated by a SELECT segment. To produce an identical SV 05 for the NMVT, enter the following:

```
SV05 = PRINTF("0B0509100004#<%s#>0040", $V2);
```

Using the **PRINTF** syntax, the %s format specifier is substituted with the value of the \$V2 variable, which is TEC. The escaped braces tell the event receiver not to translate the TEC string into numeric format, and again the following subvector produced is identical to that produced in the first two examples:

```
0B0509100004E3C5C30040
```

Any time you need to assign data that came from the original Tivoli Enterprise Console event to the output subvector, you will likely need to use the PRINTF syntax with string translation disabled. However, it is possible that the incoming event has, as an event attribute value, the string E3C5C3 instead of the string TEC. In this case, use the following string to produce the desired NMVT subvector:

```
SV05 = PRINTF("0B0509100004%s0040", $V2);
```

If you continued to disable the hexadecimal string translation, your output subvector is similar to the following:

```
0B0509100004C5F3C3F5C3F30040
```

Each of the six characters E,3,C,5,C and 3 is left in their character state (C5,F3,C3,F5,C3 and F3).

Automatic Subvector/Subfield Length Calculation

In the initial SV 05 example

```
SV05 = "0B0509100004E3C5C30040";
```

the length of the subvector was coded directly into the string. Because there is no variable information in the subvector, the length is coded directly into the event attribute value within the CDS MAP segment. The length of the subvector might not be known when the CDS file is created if variable data is used.

Consider the following example that inserts attribute list data into the subvector:

```
SV05 = PRINTF("0B0509100004#<%s#>0040", $V2);
```

In this example, the value of the \$V2 variable was TEC; therefore, it has a length of 3. This was used to calculate the total subvector length (0B), the subfield 10 length (09), and the resource name length (04). In reality, the length of the value of the \$V2 variable will be unknown until the event arrives.

To enable the event receiver to calculate the length of a portion of the subvector string, use curly braces {} around that portion of the string. The curly braces must be escaped with the escape character #. The curly braces are removed from the string when the length is calculated, but the opening curly brace is the place holder in the subvector string for the length field.

Modify the previous example as follows:

```
SV05 = PRINTF("#{05#{1000#{#<%s#>}0040#}#", $V2);
```

Following is a step-by-step translation of this event attribute. The PRINTF substitution is first as follows:

```
SV05 = "#{05#{1000#{TEC#}0040#}#";
```

At this stage, the output subvector is similar to the following:

```
...E3C5C3...
```

Where the ellipsis represent all data yet to be translated into the subvector. Next, the segment #{TEC#} is used to calculate the length of the resource name entry.

The output subvector is as follows:

```
...04E3C5C3...
```

The first #{ is replaced with the length of the segment, the matching #} is removed. Next, the segment #{100004TEC0040#} is used to calculate the length of the subfield 10 entry.

The output subvector is as follows:

```
...09100004E3C5C30040
```

Again, the #{ is replaced with the length of the segment, the matching #} is removed. Finally, the segment #{05091000100004TEC0040#} is used to calculate the length of the entire subvector 05.

The final output subvector is as follows:

```
0B0509100004E3C5C30040
```

The BUILD_SV31LIST Event Attribute

The entire original Tivoli Enterprise Console event is, by default, coded into SV 31s and attached to the NMVT. The class name, each event attribute/value pair, and the END designator are coded into separate SV 31s. The **BUILD_SV31LIST** event attribute enables the user to control whether this list of SV 31s is to be added to the NMVT. When the pseudo event is completed, if a **BUILD_SV31LIST** event attribute is present in the event AND has a value of **NO**, the SV 31 list is excluded. Otherwise, the SV 31 list is included.

The CONTINUE Slot

This event attribute is used to enable the matching of multiple CDSs to create a single pseudo event. A full description of this multiple pass process on the CDS file is given in "Matching Multiple CDSs to Create the Psuedo Event". This event attribute can have a value of either **NEXT** or **GROUPxxx**, where *xxx* is a value in the range of 000–999.

The value of this event attribute is used to update the value in the **\$CDS_GROUP** keyword. This keyword defaults to a value of **GROUP001**. If the value of a CONTINUE event attribute is **NEXT**, **\$CDS_GROUP** is updated by adding a 1 to the three numeric digits at the end of the value. If the current value of **\$CDS_GROUP** is **GROUP001**, and a CONTINUE event attribute with a value of **NEXT** is encountered in a MAP segment, the new value of the **\$CDS_GROUP** keyword will be **GROUP001**.

If the value of the CONTINUE event attribute is **GROUPxxx**, this value is used to replace the **\$CDS_GROUP** value **only** if the numeric digits in the event attribute value are greater than the numeric digits in the current **\$CDS_GROUP** value.

The SF21 Slot

This event attribute is used to override the code point in any Subfield 21s that are in the SV 31s used to send the original Tivoli Enterprise Console event. The value of this event attribute must be as follows:

```
attributeName=codepoint
```

Where *attributename* is the name of any generic attribute in the input attribute list, and *codepoint* is a 2-digit hexadecimal string that defines the value to be placed in the SF 21 that is associated with the SV31 for the named generic attribute.

Like the SV event attribute, the SF21 must only be prefixed with the string SF21; any characters after this prefix are ignored.

Matching Multiple CDSs to Create the Pseudo Event

A major difference between the way that CDS files are processed by the event adapters and how the CDS file is processed by the event receiver is the number of CDSs that can be matched to produce a single Tivoli Enterprise Console event (or pseudo event, in the case of the event receiver).

The One-Pass Method

The event adapters will run through all of the statements in a CDS file until either one statement is matched or the end of the file is reached without a match. The MAP segment of that single matching CDS is then used to create the event attribute/value pairs that will go into the outgoing Tivoli Enterprise Console event.

Although this same one-pass process *could* be used to create any of the pseudo events that will be translated into an alert, it could result in a cumbersome CDS file. To illustrate this, consider the following example.

From an incoming event, create an alert that has various combinations of SV 05s and SV 92s based on event attribute/value pairs in the event. For the SV 05 creation, you look for the presence of two event attributes -- resource1 and resource2. The following four CDSs map the SV 05:

```
CLASS SV05_1
  SELECT
    1: ATTR(=,resource1);
    2: ATTR(=,resource2);
  MAP
    SV05 = PRINTF("#{05#{1000#{#<%s#>}0084#{#<%s#>}0040#}#", $V1, $V2);
END

CLASS SV05_2
  SELECT
    1: ATTR(=,resource1);
  MAP
    SV05 = PRINTF("#{05#{1000#{#<%s#>}0084#}#", $V1);
END
CLASS SV05_3
  SELECT
    1: ATTR(=,resource2);
  MAP
    SV05 = PRINTF("#{05#{1000#{#<%s#>}0040#}#", $V1);
END

CLASS SV05_4
  SELECT
    1: ATTR(=,$CLASSNAME);
  MAP
    SV05 = "#{05#{1000#{#<NONE#>}0084#}#";
END
```

To produce the four different event attributes, different SELECT segments must be used to inspect for the presence of these event attributes; therefore, there will be 4 different CDSs in the CDS file. Only one of these SV 05s will be in the pseudo event. The last CDS uses the \$CLASSNAME keyword as a default. This keyword will always be present, so the last CDS will be selected if none of the other CDSs are matched.

The SV 92 subvector depends on value of another event attribute, severity. There are three different values for the severity event attribute that could result in

different SV 92s, and a fourth SV 92 that is created if the severity event attribute contains none of these values. These CDSs are as follows:

```

CLASS SV92_1
  SELECT
    1: ATTR(=,severity), VALUE(=,FATAL);
  MAP
    SV92 = "0B92010001FE0300000000"
END
CLASS SV92_2
  SELECT
    1: ATTR(=,severity), VALUE(=,WARNING);
  MAP
    SV92 = "0B92010011FE0300000000"
END
CLASS SV92_3
  SELECT
    1: ATTR(=,severity), VALUE(=,HARMLESS);
  MAP
    SV92 = "0B92010002FE0300000000"
END
CLASS SV92_4
  SELECT
    1: ATTR(=,$CLASSNAME);
  MAP
    SV92 = "0B92010012FE0300000000"
END

```

Again, this would require 4 different CDSs to produce one and only one of these 4 different event attributes.

To produce a single pseudo event that could have any combination of the above SV 05s and SV 92s using one pass through the CDS file would require 16 different CDS statements. The multiplication of the 4 statements needed to produce a unique SV05 and the 4 statements needed to produce a unique SV 92. Each of the 16 MAP segments has a single SV 05 and SV 92, representing all of the combinations that could occur. The four CDSs that represent both resources in combination with the various SV 92s are:

```

CLASS SVBOTH_1
  SELECT
    1: ATTR(=,resource1);
    2: ATTR(=,resource2);
    3: ATTR(=,severity), VALUE(=,FATAL);
  MAP
    SV05 = PRINTF("#{05#{1000#{#<%s#>}0084#{#<%s#>}0040#}#", $V1, $V2);
    SV92 = "0B92010001FE0300000000"
END
CLASS SVBOTH_2
  SELECT
    1: ATTR(=,resource1);
    2: ATTR(=,resource2);
    3: ATTR(=,severity), VALUE(=,WARNING);
  MAP
    SV05 = PRINTF("#{05#{1000#{#<%s#>}0084#{#<%s#>}0040#}#", $V1, $V2);
    SV92 = "0B92010011FE0300000000"
END
CLASS SVBOTH_3
  SELECT
    1: ATTR(=,resource1);
    2: ATTR(=,resource2);

```

```

        3: ATTR(=,severity), VALUE(=,HARMLESS);
MAP
SV05 = PRINTF("#{05#{1000#{#<%s#>}0084#{#<%s#>}0040#}#", $V1, $V2);
SV92 = "0B92010002FE0300000000"
END

CLASS SVBOTH_4
SELECT
    1: ATTR(=,resource1);
    2: ATTR(=,resource2);
MAP
SV05 = PRINTF("#{05#{1000#{#<%s#>}0084#{#<%s#>}0040#}#", $V1, $V2);
SV92 = "0B92010012FE0300000000"
END

```

When other subvectors that need to be placed in the same output NMVT are added, the number of needed CDSs and the duplication of event attribute mappings in the MAP segment grows considerably.

The Multiple-Pass Method

To alleviate this problem, the event receiver makes multiple passes through the CDS file and collects separate mappings from each segment that it matches for the one pseudo event that is created. The \$CDS_GROUP keyword and the CONTINUE event attribute are used to control the multiple pass method.

Each pass starts at the beginning of the CDS file. If a CDS is matched that contains a valid CONTINUE event attribute, at least one more pass will be made through the CDS file. If a CDS is matched that does not have a CONTINUE statement, or no CDS is matched, that pass will be the last pass through the CDS file and all of the event attributes collected to this point are used to create the pseudo event.

EVERY CDS SELECT segment **MUST** have one statement that looks for the \$CDS_GROUP keyword to be equal to a string in the range of GROUP001–GROUP999. By default, the initial value of the \$CDS_GROUP keyword is GROUP001, so the first CDS statement matched must look for this keyword to be equal to GROUP001.

When a CDS is matched, the CONTINUE event attribute definition in the MAP segment of that CDS controls whether another pass will be made to match another CDS. The CONTINUE event attribute will cause the value of the \$CDS_GROUP keyword to change to a specific value (CONTINUE = GROUP004) or to the next numeric value (CONTINUE = NEXT). If a specific value is given, it must be greater than the current value of the \$CDS_GROUP keyword.

To illustrate the usage of the \$CDS_GROUP keyword and the CONTINUE event attribute, using the previous example, fill in the keyword and event attribute as follows:

```

CLASS SV05_1
SELECT
    1: ATTR(=,$CDS_GROUP), VALUE(=,GROUP001);
    2: ATTR(=,resource1);
    3: ATTR(=,resource2);
MAP
SV05 = PRINTF("#{05#{1000#{#<%s#>}0084#{#<%s#>}0040#}#", $V2, $V3);
CONTINUE = NEXT;
END

CLASS SV05_2

```

```

SELECT
  1: ATTR(=,$CDS_GROUP), VALUE(=,GROUP001);
  2: ATTR(=,resource1);
MAP
  SV05 = PRINTF("#{05#{1000#{#<%s#>}0084#}#", $V2);
  CONTINUE = NEXT;
END
CLASS SV05_3
SELECT
  1: ATTR(=,$CDS_GROUP), VALUE(=,GROUP001);
  2: ATTR(=,resource2);
MAP
  SV05 = PRINTF("#{05#{1000#{#<%s#>}0040#}#", $V2);
  CONTINUE = NEXT;
END

CLASS SV05_4
SELECT
  1: ATTR(=,$CDS_GROUP), VALUE(=,GROUP001);
MAP
  SV05_4 = "#{05#{1000#{#<NONE#>}0084#}#";
  CONTINUE = NEXT;
END

CLASS SV92_1
SELECT
  1: ATTR(=,$CDS_GROUP), VALUE(=,GROUP002);
  2: ATTR(=,severity), VALUE(=, FATAL);
MAP
  SV92 = "0B92010001FE0300000000"
END

CLASS SV92_2
SELECT
  1: ATTR(=,$CDS_GROUP), VALUE(=,GROUP002);
  2: ATTR(=,severity), VALUE(=,WARNING);
MAP
  SV92 = "0B92010011FE0300000000"
END

CLASS SV92_3
SELECT
  1: ATTR(=,$CDS_GROUP), VALUE(=,GROUP002);
  2: ATTR(=,severity), VALUE(=,HARMLESS);
MAP
  SV92 = "0B92010002FE0300000000"
END

CLASS SV92_4
SELECT
  1: ATTR(=,$CDS_GROUP), VALUE(=,GROUP002);
MAP
  SV92 = "0B92010012FE0300000000"
END

```

When a Tivoli Enterprise Console event arrives to be translated, the first subvector created is the SV 05 subvector. Because the initial value of the \$CDS_GROUP keyword is GROUP001, the SELECT segments for all of the CDSs that create the SV 05 will look for this value. If none of the first three CDSs in this group are selected, the fourth will be selected by default. Because these CDSs define a

CONTINUE event attribute with a value of NEXT, the value of the \$CDS_GROUP keyword will be updated to GROUP002, and another pass will be made through the CDSs to attempt to match on another CDS.

All of the SV 05 CDSs will now be ignored, because the \$CDS_GROUP keyword is another value. Without this gate, the same SV 05 CDS would continue to be matched indefinitely. An SV 92 CDS will be matched next. The GROUP002 value for the \$CDS_GROUP keyword determines this. Because none of the SV 92 CDSs have a CONTINUE event attribute, this will be the last pass made through the CDS file.

Using the previous CDSs, if an event arrives with event attributes, as follows:

```
resource1=FIRSTRES  
resource2=SECNDRES  
severity=WARNING
```

The following two subvectors will be produced:

```
1B0519100009C6C9D9E2E3D9C5E2008409E2C5C3D5C4D9C5E20040  
0B92010011FE0300000000
```

Building the NMVT

When the pseudo event has been created, the NMVT will be built from data in the event attributes and keywords.

Building the SV 31s Containing the Original Event

The \$BUILD_SV31LIST keyword indicates whether the SV 31s that contain the original Tivoli Enterprise Console event data will be built. These SV 31s are added to the NMVT first. The value of this keyword is modified by the contents of the BUILD_SV31LIST event attribute.

Each SV 31 contains an element of the original event: the class name, an event attribute/value pair, or the END designator. Formatted on an NPDA screen, a simple CDS example follows (assuming that the original event had a class name of SAMPLE):

```
ORIGINAL T/EC EVENT:  
SAMPLE;  
resource1=FIRSTRES;  
resource2=SECNDRES;  
severity=WARNING;  
END
```

Overriding the SF21 Codepoint

Each SV 31 contains an SF 21 subfield. By default, the codepoint associated with this subfield is X'00'. Two codepoints allow the SV 31 to be associated with the alert description and probable causes: codepoint X'21' to probable causes, and codepoint X'22' to alert description. By default, the SV 31 associated with a *severity* event attribute is assigned a X'21' codepoint, and the SV 31 associated with a *msg* event attribute is assigned a X'22' codepoint.

You can change which SV 31 is associated with the alert description or probable causes using the SF21 event attribute. This event attribute contains the name of an attribute from the input attribute list (which must be an event attribute value from the incoming Tivoli Enterprise Console event), followed by an equal (=) sign, followed by a one byte hexadecimal codepoint. For example, if you want to associate an event attribute called eventdetail from the incoming event with the alert description, code the following CDS:

```

CLASS SF21_1
  SELECT
    1: ATTR(=,$CDS_GROUP), VALUE(=,"GROUP001");
    2: ATTR(=,eventdetail);
  MAP
    SF21_1 = PRINTF("%s=21", $N2);
END

```

The SF21_1 event attribute value follows:
eventdetail=21

When the SV 31 list is built, the data in the event attribute/value pair named by eventdetail will be associated with the alert description.

This SF 21 override only has an effect if the \$BUILD_SV31LIST keyword indicates that the SV 31 list will be built; if the list is not to be built, this event attribute is ignored.

Alert or Resolve

The value of the \$NMVT_TYPE keyword indicates whether the NMVT will be an alert NMVT (type 0000) or a resolve NMVT (type 0002). This keyword defaults to an alert NMVT. If the NMVT_TYPE event attribute is set within any matched CDS, the value of the \$NMVT_TYPE keyword is set to this event attribute.

Adding the User Subvectors

After the SV 31s are added and the NMVT type is determined, the user subvectors created from CDS MAP segments are added to the NMVT. As previously mentioned, any event attribute can be assigned a value in the MAP segment of a CDS statement. The only event attributes that will be used to build user subvectors, however, must be prefixed with SV.

If the same event attribute name is used more than once, the value of the last one is used as the value of the event attribute. Therefore, if you need multiple subvectors of the same type, name the event attributes with this subvector data uniquely. Using SV10 as the event attribute name for more than one SV 10 is not valid, because all preceding event attributes will be overwritten in the event attribute list. Use unique names such as SV10_1, SV10_2, and so forth.

The names for subvector event attributes do not necessarily correspond to the subvector. The value of an event attribute that you name as SV10_1 can contain data for a completely different subvector. The value of the subvector event attribute determines the subvector type, not the name of the event attribute.

The value of a subvector event attribute is decoded as previously described. Subvectors are added to the NMVT in the order that their defining event attributes are encountered in the MAP segments.

Calculating the AlertID for SV 92

Because the alert ID field must be calculated for the subvector at the time that NMVT is built, the event receiver will calculate the value for this field of SV 92. However, you must specify an alert ID place holder in any SV 92 event attributes that you code in a CDS file. You can put any 4 bytes there; they will be overwritten by the event receiver. It is recommended that you code four bytes of zero (00000000) as the place holder.

The event receiver calculates the alert ID as described in *SNA Formats*.

An Example

The following example uses the default event receiver service CDS file (IHSAECDs) provided in the event/automation service.

Assume the following Tivoli Enterprise Console event has been received by the event receiver:

```
SNA_Performance_Degraded;source=Nv390ALT;origin=B3088P2;
sub_origin=TX12/DEV;hostname=USIBMNT.NTVED;adapter_host=NMPIPL06;date=OCT 29 16:32:52;
severity=WARNING;msg=PERFORMANCE DEGRADED:CONTROLLER;adapter_host_snanode=USIBMNT.NTVED;
event_type=NOTIFICATION;arch_type=GENERIC_ALERT;product_id=3745;alert_id=00000009;
block_id='';action_code='';alert_cdpt=4000;self_def_msg=[ALRTXT2];event_correl=[N/A];
incident_correl=[N/A];adapter_correl=E7735930A;END
```

The previous event was an alert that was changed into an event by the alert adapter. All of the event attribute/value pairs are first coded into generic attributes for the input attribute list; the \$CLASSNAME keyword attribute is assigned the value SNA_Performance_Degraded.

The first group in the CDS file is GROUP001; these CDSs determine the NMVT type. Because there is not a status event attribute in the incoming Tivoli Enterprise Console event, the NMVT_TYPE event attribute and the \$NMVT_TYPE keyword are set to the value ALERT. Because CONTINUE=NEXT is specified in the MAP segment, the \$CDS_GROUP keyword is set to GROUP002.

The next group in the CDS file defines the SV 93. None of the information in the original event determines the value of the SV 93; the value of this subvector is as follows:

```
0493FE03
```

CONTINUE=NEXT is specified in the MAP segment. The \$CDS_GROUP keyword is set to GROUP003.

The next group in the CDS file defines the SV 05. The example event will match on the class SV05_4, it has a host name, origin, and source event attribute, but not a probe event attribute. After PRINTF and translation, the value of this subvector follows:

```
2A052810000EE4E2C9C2D4D5E34BD5E3E5C5C4008408C2F3F0F8F8D7F200F509D5E5F3F9F0C1D3E30040
```

CONTINUE=NEXT is specified in the MAP segment. The \$CDS_GROUP keyword is set to GROUP004.

The next group in the CDS file defines the SV 10. None of the information in the original event determines the value of the SV 10; the value of this subvector follows:

```
1C10001911040506C7C5D40908F5F6F9F7C2F8F3080FE3C9E5D6D3C9
```

CONTINUE=NEXT is specified in the MAP segment. The \$CDS_GROUP keyword is set to GROUP005.

The next group in the CDS file defines the SV 92. The example event will match on the class SV92_4, it has severity=WARNING and the \$NMVT_TYPE is set to ALERT. The value of this subvector follows:

```
0B92010011FE0300000000
```

The alert ID portion of this subvector (the last 4 bytes) will be calculated and filled in by the event receiver. CONTINUE=NEXT is specified in the MAP segment. The \$CDS_GROUP keyword is set to GROUP006.

The next group in the CDS file defines the SV 97. The example event will match on the class SV97_1, the \$NMVT_TYPE is set to ALERT. The value of this subvector follows:

```
0A970881200035003000
```

CONTINUE=NEXT is specified in the MAP segment. The \$CDS_GROUP keyword is set to GROUP007.

The next group in the CDS file defines an SF 21. The example event will match on the one and only CDS for this group, the msg event attribute is present in the event. The value of this subfield override follows:

```
msg=21
```

CONTINUE=NEXT is specified in the MAP segment. The \$CDS_GROUP keyword is set to GROUP008.

The last group in the CDS file defines another SF 21. The example event will match on this last CDS, the severity event attribute is present in the event. The value of this subfield override follows:

```
severity=22
```

The \$BUILD_SV31LIST keyword is still set to YES. The NMVT built from the previous process follows:

```
03D800002B310602028000000512C5D5E40321001B30E2D5C16DD7859986969994819583
856DC4858799818485845E22310602028000000512C5D5E40321001230A296A49983857E
D5E5F3F9F0C1D3E35E4A310602028000000512C5D5E40321003A309699898789957EC2F3
F0F8F8D7F261E2D76BD5C1D761E3D76BC4C5C3D5C5E361E3C5D9D46BD9C1D3E5F461C4C5
E56BE3E7F1F261C4C5E55E26310602028000000512C5D5E40321001630A2A4826D969989
8789957EE3E7F1F261C4C5E55E29310602028000000512C5D5E403210019308896A2A395
8194857EE4E2C9C2D4D5E34BD5E3E5C5C45E28310602028000000512C5D5E40321001830
81848197A385996D8896A2A37ED5D4D7C9D7D3F0F65E27310602028000000512C5D5E403
210017308481A3857ED6C3E340F2F940F1F67AF3F27AF5F25E23310602028000000512C5
D5E40321221330A285A5859989A3A87EE6C1D9D5C9D5C75E36310602028000000512C5D5
E4032121263094A2877ED7C5D9C6D6D9D4C1D5C3C540C4C5C7D9C1C4C5C47AC3D6D5E3D9
D6D3D3C5D95E35310602028000000512C5D5E4032100253081848197A385996D8896A2A3
6DA29581959684857EE4E2C9C2D4D5E34BD5E3E5C5C45E2A310602028000000512C5D5E4
0321001A3085A58595A36DA3A897857ED5D6E3C9C6C9C3C1E3C9D6D55E2A310602028000
000512C5D5E40321001A30819983886DA3A897857EC7C5D5C5D9C9C36DC1D3C5D9E35E22
310602028000000512C5D5E4032100123097999684A483A36D89847EF3F7F4F55E243106
02028000000512C5D5E4032100143081938599A36D89847EF0F0F0F0F0F0F95E1E3106
02028000000512C5D5E40321000E3082939683926D89847E7D7D5E213106020280000005
12C5D5E403210011308183A38996956D839684857E7D7D5E22310602028000000512C5D5
E4032100123081938599A36D838497A37EF4F0F0F0E2A310602028000000512C5D5E403
21001A30A28593866D8485866D9A42877EADC1D3D9E3E3E7E3F2BD5E2531060202800000
0512C5D5E4032100153085A58595A36D839699985937EADD561C1BD5E28310602028000
000512C5D5E4032100183089958389848595A36D839699985937EADD561C1BD5E2B3106
02028000000512C5D5E40321001B3081848197A385996D839699985937EC5F7F7F3F5F9
F3F0C15E15310602028000000512C5D5E40321000530C5D5C40493FE032A052810000EE4
E2C9C2D4D5E34BD5E3E5C5C4008408C2F3F0F8F8D7F200F509D5E5F3F9F0C1D3E300401C
10001911040506C7C5D40908F5F6F9F7C2F8F3080FE3C9E5D6D3C90B92010011FE030000
00000A970881200035003000
```

Translating ASCII Text Data

SNMP agents send up data (whether in variable bindings or other parts of the trap) that is essentially ASCII text data, but the data type in the encoding trap

indicates an octet string. Since the data type is an octet string, the trap-to-alert data encoding process treats each byte of data as raw hexadecimal data rather than an encoded character. As a result, the parsing done by the trap-to-alert conversion task merely turns this data into a character representation of the hex data bytes for in SELECT criteria in the CDS file. For example, assume the character string **ABC** appears in a variable binding value with a type of octet string. Since the data is an octet string, the data is converted to the character string **414243** and assigned to the generic keyword associated with the variable binding name.

If you want to use the original ASCII string value of the generic keyword in the outgoing alert, the ASCII string **414243** needs to be converted back to the character string **ABC** and changed to EBCDIC. The `[$[and $]` escape sequence has been provided to allow for conversion of the EBCDIC character string **414243** back to the EBCDIC character string **ABC**.

Within the value encoding, inside the double quotes for the value of the subvector event attribute (whether in a PRINTF or not), this escape set is used to delimit data that is considered to be the character representation of hex data that, in turn, is ASCII character data. Data delimited in this way is turned into EBCDIC character data and placed within the value of the subvector event attribute. For example, if you had the following event attribute assignment in a Class Definition Statement:

```
SV05 = "0B0509100004#[414243#]0040"
```

The encoding of this event attribute value into an actual hexadecimal alert subvector would produce:

```
0B0509100004C1C2C30040
```

If data within the range delimited by the escape sequences turns out not to be character representations of hex data that are ASCII characters, then the conversion to EBCDIC will fail, and the translation of the trap (and thus, building of the alert/resolve) is terminated and the trap is discarded. Note that if other escape sequences occur following `"#[` and before `"#]` is encountered, they are simply treated as characters that are put into the subvector, which would later fail conversion to hex then EBCDIC, because they aren't character representations of hex digits. Also, if `"#[` or `"#]` occur following the `"#<` escape sequence, which "turns off" translation of character representations of hex digits to hex data in the subvector, and before `"#>`, which "restores" that translation mode, then `"#[` and `"#]` are simply treated as untranslated character data, not escape sequences.

Translating SNMP Non-String Data Types

Some attributes used in CDS selection are assigned names based upon the places in the trap from which their values are extracted, while other names are adapted directly from the trap (for example, variable names, which are object identifiers, in the variable bindings). The encoded values are all string data, displayable forms of the data within the trap, and the formats of these strings depend upon the data types assigned to these pieces of data in the trap.

As an example, suppose that the data type of a value in the trap was found to be that of an internet address. The trap-to-alert conversion task would turn this into a string which was the internet address in dotted decimal notation. The following data types can be assigned to data in an SNMP trap, and the corresponding string to which it is translated.

integer

signed decimal number string. The integer 30 becomes the EBCDIC string "30"

- null** a pair of single quotes in EBCDIC. This becomes the EBCDIC string "".
- octet string**
hexadecimal data string. The hex string 313233 becomes the EBCDIC string "313233".
- object identifier**
ASN.1 data in dotted decimal notation format. The object 2C010306 becomes the EBCDIC string "1.4.1.3.6".
- printable string**
an EBCDIC string
- visible string**
an EBCDIC string
- general string**
an EBCDIC string
- internet address**
dotted decimal notation format. The address 09080706 becomes the EBCDIC string "9.8.7.6".
- counter**
unsigned decimal number string. The number 05 becomes the EBCDIC string "5".
- gauge** unsigned decimal number string. The number 50 becomes the EBCDIC string "50".
- ticks** unsigned decimal number string. The number 132 becomes the EBCDIC string "132".

When the value is not of a data type listed above, then that value is treated as if it had a data type of octet string. Also, if the data type of the value in the binding is a complex structure like SEQUENCE OF (something that should not happen), then the value is treated as if it had the null data type.

The following example uses the default trap-to-alert service CDS file (IHSATCDS) supplied with the event/automation service. Assume the following trap data is received by the trap-to-alert conversion task (words separated for readability).

```
303B0201 00040670 75626C69 63A42E06
0C2B0601 14011203 01020101 03400449
B5203F02 01050201 00430100 300F300D
06082B06 01120108 07000201 30
```

Also assume that the IP address and port associated with the agent originating the trap is 9.50.20.8 and 161, respectively.

The trap data is first coded into corresponding keyword and generic attributes for the input attribute list. The encoded string attributes are:

```
$ORIGIN_ADDR      9.50.20.8
$ORIGIN_PORT      161
$SNMP_VERSION     0
community         public
enterpriseOID
1.3.6.1.20.1.18.3.1.3.1.1.3
agent_address     73.181.32.63
generic_trap      5
specific_trap     0
timestamp         0
1.3.6.1.18.1.8.7.0 30
```

The first group in the CDS file is GROUP001; this CDS determines the NMVT type and BUILD_SV31LIST setting. Since this trap is not a Multi-System Manager trap, the generic formatting done by the CDS file IHSATALL is used. The NMVT_TYPE event attribute (and therefore, the \$NMVT_TYPE keyword) is set to the value ALERT. The BUILD_SV31LIST event attribute (and therefore, the \$BUILD_SV31LIST keyword) is set to the value YES. Since CONTINUE=NEXT is specified in the MAP segment, the \$CDS_GROUP keyword is set to GROUP002.

The next group in the CDS file defines the SV 92. The value of this subvector is:
0B92080012FE0000000000

The Alert ID portion of this subvector (the last 4 bytes) will be calculated and filled in by the event receiver. CONTINUE=NEXT is specified in the MAP segment, the \$CDS_GROUP keyword is set to GROUP003.

The next group in the CDS file defines the SV 05. After PRINTF and translation, the value of this subvector is:

22050E100009F7F34BF1F8F14BF300811211000DF7F34BF1F8F14BF3F24BF6F30081

CONTINUE=NEXT is specified in the MAP segment, the \$CDS_GROUP keyword is set to GROUP004.

The next group in the CDS file defines the SV 10. The value of this subvector is:

5A1000281103030000220EE261F3F9F040D78199819393859340C595A3859997
9989A28540E28599A585992F11040804F0F1F0F3F0F01B06E389A596938940D5
85A3E58985A64086969940D6E261F3F9F00908F5F6F9F7C2F8F2

CONTINUE=NEXT is specified in the MAP segment, the \$CDS_GROUP keyword is set to GROUP005.

The next group in the CDS file defines another SV 10, which contains information about the resource reporting the trap. The value of this subvector is:

2C10000F1109030000090EA495929596A6951A110C0E02F0F0F0F0F0F0F0F0
F0F0F00906A495929596A695

CONTINUE=NEXT is specified in the MAP segment, the \$CDS_GROUP keyword is set to GROUP006.

The next group in the CDS file defines the SV 93 and SV 97. The value of these subvectors are:

0493FE000
A970401210004810000

CONTINUE=NEXT is specified in the MAP segment, the \$CDS_GROUP keyword is set to GROUP007.

The last group in the CDS file defines the SV 98. The enterpriseOID, specific trap, and generic trap values are added as information in this subvector. The value of this subvector is:

severity=22

The \$BUILD_SV31LIST keyword is still set to YES, the actual NMVT built from the previous process is:

027B000029310602028000000512C5D5E40321001930D6D9C9C7C9D56DC1C4C4D97EF94B
F6F74BF5F04BF1F85E23310602028000000512C5D5E40321001330D6D9C9C7C9D56DD7D6
D9E37EF1F0F3F45E21310602028000000512C5D5E40321001130E2D5D4D76DE5C5D9E2C9

```
D6D57EF05E29310602028000000512C5D5E4032100193083969494A49589A3A87EF7F0F7
F5F6F2F6C3F6F9F6F35E3C310602028000000512C5D5E40321002C308595A38599979989
A285D6C9C47EF14BF34BF64BF14BF2F04BF14BF1F84BF34BF14BF24BF14BF14BF35E2D31
0602028000000512C5D5E40321001D3081878595A36D8184849985A2A27EF7F34BF1F8F1
4BF3F24BF6F35E21310602028000000512C5D5E40321001130878595859989836DA39981
977EF55E22310602028000000512C5D5E40321001230A2978583898689836DA39981977E
F05E1E310602028000000512C5D5E40321000E30A3899485A2A38194977EF05E28310602
028000000512C5D5E40321001830F14BF34BF64BF14BF1F84BF14BF84BF74BF07EF4F85E
0B92080012FE00331AA4A122050E100009F7F34BF1F8F14BF300811211000DF7F34BF1F8
F14BF3F24BF6F300815A1000281103030000220EE261F3F9F040D78199819393859340C5
95A38599979989A28540E28599A585992F11040804F0F1F0F3F0F01B06E389A596938940
D585A3E58985A64086969940D6E261F3F9F00908F5F6F9F7C2F8F22C1000F1109030000
090EA495929596A6951A110C0E02F0F0F0F0F0F0F0F0F0F0F0F0F0F0F0F0F0F0F0F0F0F0F0
93FE000A9704012100048100002E98208229F811F14BF34BF64BF14BF2F04BF14BF1F84B
F34BF14BF24BF14BF14BF3068229FA11F5068229F11F0
```

Trap-to-Alert Post-CDS Processing

The trap-to-alert service post-CDS processing is nearly identical to that used by the event receiver post-CDS processing. The differences are:

- There is no `$CLASSNAME` keyword created by the trap-to-alert service since the incoming data was not a Tivoli Enterprise Console event.
- An additional escape sequence set `[$[and $]` is available to aid in translating variable binding data that are ASCII octet strings.
- Unlike Tivoli Enterprise Console event data, SNMP trap data can have a data type other than a character string.

Advanced Customization - Trap-to-Alert Forwarding Daemon

The way the event/automation service trap-to-alert conversion task receives traps is through a datagram socket which is bound to a port that you define in the configuration file (sample member name `IHSATCFG`). The conventional trap manager data port number, 162, is the default port.

Since port 162 is a "well-known" port for SNMP managers, and there may be multiple SNMP manager applications that are interested in trap data, this sort of port assignment can cause a conflict. To help resolve any conflicts, there is also a sample datagram forwarding daemon, `IHSAUFW`, and an associated sample configuration file, `IHSAUCFG`, that are shipped with the event/automation service. The daemon receives data on a datagram socket and forwards that data to the destinations given in the configuration file.

Most SNMP agents are set to forward traps to the trap manager at port 162. `IHSAUFW` can use this port to receive the trap data for all interested managers and then forward this data to the managers. These managers can be on the local system or at any IP address on the network.

The `IHSAUFW` daemon uses a sample configuration file (`IHSAUCFG`) to specify the SNMP managers that are to receive the data. A description of the contents of this configuration file follows:

comments

Comments may be formed by beginning a line with the pound sign (number sign), `"#"`, or the exclamation point, `"!"`.

host internet address and port

To code a destination for the datagram forwarding daemon, put the following on a line in the file:

- internet address in dotted decimal notation

- white space (one or more blanks)
- port number, in decimal

An example of a lone coded like this would be:

```
137.45.110.2      6001
```

For more information on how to use and customize the forwarding daemon, refer to the comments in the IHSAUFWD sample.

Alert-to-Trap Post-CDS Processing

The alert-to-trap service post CDS processing converts the Tivoli Enterprise Console event that is produced from the CDS process into an SNMP trap.

All non-variable binding information in the trap is put into the constructed trap by the alert-to-trap service directly, without the opportunity to customize it using the CDS file. The only exception to this is the specific trap value.

The alert-to-trap adapter sets the non-variable binding fields as follows:

version

0

community

the value of the community statement from the alert-to-trap configuration file (IHSAATCF)

enterpriseOID

the value of the enterpriseOID statement from the alert-to-trap configuration file

IP address

the local host IP address

generic type

6

timestamp

0

The specific type is taken from the value of the specific event attribute that is created by the CDS processing.

All other event attribute/value pairs are encoded into variable bindings on the trap. The object id used for each of the variable bindings is the Enterprise OID from the alert-to-trap configuration file. The value of the binding has the form:
slot=value

where slot is the name of the event attribute from the CDS processing, and value is the value of that event attribute. The specific event attribute is not included in the variable bindings since its value is put in the specific type field of the trap.

Chapter 9. NetView Instrumentation

NetView instrumentation consists of subsystems. The topology display subsystem is available if you have NetView management console (NMC) or Tivoli Global Enterprise Manager (Tivoli GEM). For any other subsystem, including the event flow subsystem, Tivoli GEM must be installed.

Considerations

Instrumentation uses REXX CLISTs that invoke API functions. The API consists of compiled REXX. The REXX run time libraries are included in this release of NetView. However, if you are using a previous version, the REXX run time libraries must be included in the NetView steplib.

Events carrying management information to the topology server start as messages containing keyword/value pairs. These messages issued by the API are BNH351I, BNH352I, BNH353I, and BNH354I. These messages will be converted and forwarded to a topology server.

For earlier versions of NetView, instrumentation support (issuing and forwarding the BNH351I - BNH354I messages) requires the following APAR numbers to be available on your system:

- For NetView Version 2 Release 4 — OW30165
- For NetView Version 3 — OW31603
- For TME[®] 10 NetView for OS/390 Version 1 Release 1 — OW31604

Customization

The following samples were updated for application management instrumentation. You may need to customize them for your environment.

- **CNMSTYLE**

Use CNMSTYLE to add automation table DSIAMIAT and autotask AUTOAMI.

Also, uncomment the TOWER for AMI statement:

```
TOWER = *SA *AON *MSM *Graphics MVScmdMgt NPDA *TARA NLDM *AMI
```

- **DSIAMIAT**- in sample DSIPARM

A separate automation table for application management instrumentation. You need to uncomment one of the following includes:

- %INCLUDE DSIAMIR - to route the BNH351-BNH354 messages to another NetView. Use this for NetView Version 2 Release 4 and Version 3 Release 1.
- %INCLUDE DSIAMIT - to route the BHN351-BNH354 messages to a message adapter (the event automation service should be started). You may need to modify the PPI receiver ID of your event automation service message adapter (default is IHSATEC). The message adapter converts and sends the messages to the Tivoli Enterprise Console. The console rules format and send the converted messages to the appropriate topology servers.

Configure the message adapter by including IHSAAPMF in the message adapter format file. Refer to the *Tivoli NetView for z/OS Installation: Configuring Additional Components* for more information.

Configure the Tivoli Enterprise Console by importing the files `interapp.baroc` and `interapp.rls` to your rules base and entering the address of your topology server in the file `ihsttec.cfg`. Refer to the *Tivoli GEM Installation Guide* for more information.

- `%INCLUDE DSIAMIN` - to route the BHN351-BNH354 messages directly to a topology server across NETCONV (this is the default)

- **DSIAMII**- in sample DSIPARM

Application management instrumentation member

- On the focal point NetView (the NetView that routes messages to the topology server or message adapter), code the NetView domain of all remote NetViews (if any) with the `RMTLU=luname` keyword.
- Customize the monitor default threshold specifications and polling intervals as appropriate for your environment. Note that the defaults defined here apply to all instances of a component or connection type. You can change threshold specifications and polling intervals for a specific instance by invoking the `set threshold` or `set polling interval` tasks.

You can define multiple threshold specifications. Each one consists of three values. The first value is the threshold value, the second value is the operator, the third value is the severity of the threshold event. For example:

```
BEGIN_THRESHOLD
SS=Tivoli;TME10NVCNMTAMEL;1.2
MONITOR=('STATE'UP,6,0,DOWN,6,5 MVR=CNMETDMV 10)
MONITOR=('IPC QUEUE' 25,8,2)
MONITOR=('VIEWMGR QUEUE' 25,8,2)
MONITOR=('VSTATMGR QUEUE' 25,8,2)
END_THRESHOLD
```

In the example, for the `IPC QUEUE` monitor, when the current value crosses above (operator 8) 25, a `WARNING` (2) threshold event is sent.

The meaning of each value is:

1. The threshold value against which the current monitor value is compared.
2. The comparison operator used to compare the current monitor value against the threshold value:

```
0 = greater than
1 = greater than or equal
2 = less than
3 = less than or equal
4 = equal
5 = not equal
6 = changes to
7 = changes from
8 = crosses above
9 = crosses below
10 = matches
11 = does not match
```

3. The severity of the threshold event to be sent if a match occurs follows:

```
0 = "NORMAL"
1 = "INFORMATIONAL"
2 = "WARNING"
3 = "SEVERE"
4 = "CRITICAL"
5 = "FATAL"
```

- The following list details what you can customize in DSIAMII to activate one or all of the components.

- Hardware monitor component

```
INIT=CNME3016(60)
TERM=CNME3017()
```

The parameter for CNME3016 is the heartbeat_interval.

- Event/automation service components (message adapter, alert adapter, event receiver)

```
INIT=CNME9503(60 IHSAEVNT.IHSATEC)
TERM=CNME9531()
```

Change the INIT=CNME9503 statement to include the procname and PPI receiver ID of your adapters.

- MSM agent instrumentation

```
INIT=FLCAPMIN(60)
TERM=FLCAPMTR()
```

The parameter for FLCAPMIN is the heartbeat_interval.

- Topology display subsystem components. These DSIAMII members have multiple statements for instrumentation initialization. The statements are as follows:

```
INIT=CNMETDIN(HBEAT,60)
INIT=CNMETDIN(QDEPTH,10)
INIT=CNMETDIN(GMFHS,CNMSJH10.C)
INIT=CNMETDIN(GPARM,DOMAIN=CNM01)
INIT=CNMETDIN(RODM,EKGXRODM.X)
INIT=CNMETDIN(COLDPARAM,TYPE=COLD,INIT=EKGLISLM)
INIT=CNMETDIN(WARMPARM,TYPE=WARM)
INIT=CNMETDIN(COMPLETE)
```

The parameters are:

- HBEAT specifies the heartbeat. It is required.
- QDEPTH specifies the queue depth. It is required.
- GMFHS specifies the GMFHS start-up procedure and its alias. It is required.
- GPARM specifies the parameters to be used with the GMFHS start-up procedure. It is not required but if the domain value is not specified here, GMFHS will look to find the domain in the GMFHS initialization member DUGINIT or in the specified GMFHS start-up procedure.
- RODM specifies the RODM start-up procedure and its alias. It is required.
- COLDPARAM specifies the parameters for a RODM start-up procedure when a user chooses to do a RODM cold start. It is not required.
- WARMPARM specifies the parameters for a RODM start-up procedure when a user chooses to do a RODM warm start. It is not required.

If you create GEM instrumentation, you should modify DSIAMII to add default threshold specifications and calls to instrumentation initialization and termination routines. Refer to the *Tivoli Global Enterprise Manager Instrumentation Guide* for API descriptions.

Refer to the *Tivoli Global Enterprise Manager CICSplex SM Instrumentation User's Guide* for information about customizing DSIAMII.

Starting and Stopping Instrumentation

To start instrumentation, issue the INITAMI command on the focal point NetView (the NetView that routes messages to the message adapter). INITAMI is automatically issued on NetViews defined as remote in DSIAMII. The INITAMI command starts the AUTOAMI on the focal point NetView (if not already started). The console id for AUTOAMI is set to AMIxxxxx where xxxxx is the five rightmost characters of the NetView domain. Therefore, the console ID will be unique within a sysplex, and the commands issued from the autotask will correlate.

Instrumentation is not, however, forced to run on AUTOAMI. Therefore, in environments with multiple NetViews in a system, or in a sysplex, the INITAMI command should be issued on autotask AUTOAMI.

The INITAMI command also establishes a RMTCMD session with any NetView whose domain name is coded on the RMTLU statement in DSIAMII. This will log on the AUTOAMI autotask on that NetView.

To stop instrumentation, issue the TERMAMI command. TERMAMI is automatically issued on NetViews defined as remote in DSIAMII. In addition, stop the AUTOAMI autotask on the focal point NetView. This ends the RMTCMD sessions established by INITAMI.

The topology server may issue instrumentation related commands after issuing the TERMAMI command. However, the AUTOAMI autotask must be started for this to work.

Customizing the Tivoli Enterprise Console

If you route the instrumentation messages to the Tivoli Enterprise Console through the event automation service message adapter, you will need to customize the console.

ACB Monitor Customization

The application control block (ACB) Monitor focal point receives status updates for ACBs from the focal point Virtual Telecommunications Access Method (VTAM) and entry point VTAMs. If used in conjunction with Tivoli Business System Manager (TBSM), the ACB Monitor discovers the following:

- generic resources
- user-specified applications,
- applications matching user-specified models

The ACB Monitor also monitors the following:

- ACB status
- session count
- persistent recovery events for ACB applications

If used in conjunction with TBSM or with NMC TN3270 management, the ACB Monitor discovers TN3270 servers and clients. Optionally, ACB data can be saved in a DB2 database.

Define one ACB Monitor focal point for each System complex (or sysplex, the set of MVS and or z/OS systems). To fully enable instrumentation of application dynamics in a sysplex environment, define all other images in the sysplex to be entry points of that focal point.

Saving ACB data in DB2 enables you to query telnet clients by IP address, host name, or application name (using the Locate TN3270 Client TBSM tasks). This also enables you to change your list of critical TN3270 client resources without restarting the ACB Monitor.

Notes:

1. To save ACB data to DB2, DB2 must be operational on the ACB Monitor focal point, and the NetView SQL pipe stage must be enabled.
2. The AMI must be enabled on the ACB Monitor focal point to enable the ACB Monitor instrumentation.

Parts

The parts that are shipped as part of the ACB Monitor are listed in Table 19.

Table 19. TBSM parts list

Part Name	Language	Function
TN3270.BSDF	MIF	TN3270 business system description file
TN3270.BCDF	MIF	TN3270 business component description file
TN3270.BMDF	MIF	TN3270 business mapping description file
TN3270.CDF	MIF	TN3270 component definition file
Ltn3270loc.ddf	DDF	Locate TN3270 client local dialog definition
Ltn3270glob.ddf	DDF	Locate TN3270 client global dialog definition
TN3270.html	HTML	Help file
GENRSC.BSDF	MIF	Generic Resources business system description file
GENRSC.BCDF	MIF	Generic Resources business component description file
GENRSC.BMDF	MIF	Generic Resources business mapping description file
GENRSC.CDF	MIF	Generic Resources component definition file
GENRSC.html	HTML	Help file
VTAMAPPL.BSDF	MIF	VTAM Application business system description file
VTAMAPPL.BCDF	MIF	VTAM Application business component description file
VTAMAPPL.BMDF	MIF	VTAM Application business mapping description file
VTAMAPPL.CDF	MIF	VTAM Application component definition file
VTAMAPPL.html	HTML	Help file

Defining a Focal Point

To define an ACB Monitor focal point, perform the following steps:

1. Customize the automation table in sample DSIAMIAT. Uncomment the following include: %INCLUDE CNMSVTFT.

2. Customize the AMI configuration member in sample DSIAMII using the following steps:
 - a. Code the NetView domain name of each ACB Monitor entry point on `AMONLU=keyword`.
 - b. Do you want to save ACB data to DB2?
 - If yes, perform steps 2c and 2d.
 - If no, go to step 2e.
 - c. Code `AMONDB2=y`.
 - d. Code the DB2 volume on `DB2VOL=keyword`.
 - e. Code the DB2 volume catalog on `DB2VCAT=keyword`.
 - f. Code the DB2 buffer pool on `DB2BUFFERPOOL=keyword` for each predefined VTAM Application to be monitored. An icon will be added to the GEM VTAM Applications view for each Application.
3. Customize the list of VTAM applications and models to be discovered in sample DSIAMII as follows:
 - a. Code the application name on `APPLCOMPONENT=applname` for each predefined VTAM application to be monitored. An icon will be added to the TBSM VTAM applications.
 - b. Code the model name on `MODELCOMPONENT=modelname` for each VTAM model to be monitored. An icon will be added to the TBSM VTAM Applications view for each Application cloned from that model name.
4. Do you want to save ACB data to DB2?
 - If no, go to step 5.
 - If yes, customize the DB2 parameters in sample DSIAMII by completing the following steps:
 - a. Code `AMONDB2=Y`.
 - b. Code the DB2 volume on `DB2VOL=keyword`.
 - c. Code the DB2 volume catalog on `DB2VCAT=keyword`.
 - d. Code the DB2 buffer pool on `DB2BUFFERPOOL=keyword`.
5. Customize the default thresholds in sample DSIAMII. You can customize any of the following:
 - when threshold events are issued for the ACB status monitor
 - the severity of the events issued for the ACB status monitor
 - the session count monitor
 - the persistent recovery monitor

Customization in DSIAMII defines default thresholds. You can also customize thresholds for each instance (icon) with the set threshold task.

For example, if you want to change the threshold severity of CONCT and RESET states to SEVERE (3) rather than INFORMATIONAL (1) for APPLCOMPONENT and MODELCOMPONENT Applications, change the following line:

```
ACT,6,0,CONCT,6,1,RESET,6,1,INACT,6,2,UNKNOWN,6,2,PINACT,6,4,PACT,6,4
```

To:

```
ACT,6,0,CONCT,6,3,RESET,6,3,INACT,6,2,UNKNOWN,6,2,PINACT,6,4,PACT,6,4
```

Or, if you want a WARNING threshold event to be issued when session counts exceed 999, and a NORMAL threshold event when session counts fall below 1000, change the following line:

```
MONITOR=('SESSION COUNT' 0,1,0 EVENT)
```

To:

```
MONITOR=('SESSION COUNT' 999,8,2,1000,9,0 EVENT)
```

6. Install the ACB Monitor VTAM exit. Link edit CSECT CNMIETMN into load module ISTIETMN in the VTAMLIB DD for VTAM.

Defining An Entry Point

To define an ACB Monitor entry point, perform the following steps.

- Step 1. Customize the automation table in sample DSIAMIAT. Uncomment the following include: %INCLUDE CNMSVTET
- Step 2. Install the ACB Monitor VTAM exit. Linked CSECT CNMIETMN into load module ISTIETMN in the VTAMLIB DD of VTAM.

Starting the VTAM ACB Monitor

Start the AMI by issuing the **INITAMI** command on the focal point NetView to enable instrumentation for:

- generic resource
- TN3270 servers
- APPLCOMPONENT VTAM applications
- MODELCOMPONENT VTAM applications

To start the VTAM ACB Monitor, issue the **INITAMON** command on the focal point NetView. The focal point and all entry points identified on the *AMONLU=keyword* will be activated.

After the VTAM ACB Monitor has been activated, issue the **INITAMON** *entry_point* command, to activate an additional entry point, where *entry_point* is the NetView domain name of the entry point.

Recovering a VTAM ACB Monitor Entry Point

When the RMTCMD LU 6.2 session between an entry point and the focal point fails, the entry point is automatically stopped. When the error that caused the communication failure between the two NetViews has been corrected, issue the **INITAMON** *entry_point* command on the focal point to recover the entry point.

Stopping the VTAM ACB Monitor

To stop the VTAM ACB Monitor, issue the **TERMAMON** command on the focal point NetView. The focal point and all active entry points will be deactivated. All GEM components will be removed for:

- generic resource
- TN3270 instrumentation
- APPLCOMPONENT instrumentation
- MODELCOMPONENT instrumentation.

To stop a specific entry point, issue the **TERMAMON** *entry_point* command, where *entry_point* is the NetView domain name of the entry point. Status for all of the applications on the VTAM associated with that NetView will be removed from the database, and all GEM components which represent resources on that VTAM will be removed for:

- generic resource

- TN3270 instrumentation
- MODELCOMPONENT instrumentation.

Chapter 10. Writing a Java Application for the NetView 3270 Management Console

IBM eNetwork Host-On-Demand provides a host access class library to enable users to write Java™ applications to automate NetView 3270 management console (NMC-3270) sessions. These automation applications can be used to interact with the NMC-3270-provided sessions for routine tasks. The automation applications can also be used from GEM or the NMC.

Providing a Host Access class library application for the NMC-3270 involves the following steps:

- Writing the application
- Launching the application either at NMC-3270 startup or from a dialog.

Refer to the *IBM eNetwork Host Access Class* for more information. Information is also available from the NetView 3270 management console menu bar (select Books).

Writing a NetView 3270 Management Console Host Access Class Library Application

The Host Access Class Library (HACL) classes associated with a particular NetView session can be obtained from an instance of `ECLSession`.

To do this, the application must implement `FLB_NVApp1Interface`. This interface provides the methods for passing the active session to the application which is done through the `init` method of the interface.

After getting a session object in the `init` method, you can gain access to the presentation space and interact with it. The presentation space is encapsulated in the `ECLPS` class, and an instance of it can be obtained using the `GetPS()` method on `ECLSession`. `ECLPS` provides methods that:

- Manipulate text
- Perform searches
- Send keystrokes to the host
- Work with the cursor.

The following sample gets an instance of `ECLPS` from the session described above.

```
public void init(ECLSession session)
{
    ps = session.GetPS();
    oia = session.GetOIA();
}
```

When an instance of `ECLPS` is established, you can register as a `com.ibm.eNetwork.ECL.event.ECLPSListener` to receive notification of presentation space changes. Registered listeners are notified when the presentation space is changed. This event notification model is the primary mechanism used by an application to drive interactions with the presentation space.

The sample code below registers the current class with the instance of ECLPS.

```
try {
    ps.RegisterPSEvent(this);
} catch(ECLerr e) { System.out.println(e.GetMsgText()); }
```

Even though you are registered for presentation space events, you still need to implement `com.ibm.eNetwork.ECL.event.ECLPSListener` interface.

The `ECLPSListener` interface is comprised of three methods which handle different kinds of events occurring within the presentation space. The `PSNotifyEvent()` method handles normal, non-error events and is the main method for receiving and handling events. The `PSNotifyStop()` method handles stop events, and the `PSNotifyError()` method handles errors which occur during event generation.

The following sample defines a `PSNotifyEvent()` method which prints out screen updates.

```
public void PSNotifyEvent(ECLPSEvent evt)
{
    try
    {
        char[] temp = new char[1921]; // Screen size is assumed to be 24x80
        ps.GetScreen(temp, 1920, 1, 1920, ps.TEXT_PLANE);
        System.out.println(new String(temp));
        ps.UnregisterPSEvent(this);
    }
    catch (Exception ECLerr)
    {
        System.out.println("ECLerr Exception --> " + ECLerr.toString());
    }
}
```

`FLB_NVAppInterface` also requires you to implement three other methods (`addListener`, `removeListener`, and `closeDown`) which allow the application to listen for a `closeDown` event from the NMC-3270. The `closeDown` event is triggered when the NMC-3270 is ready to close the session. The `closeDown` method allows the user to clean up before the session ends. The `removeListener` method stops the application from listening for `closeDown` events from the NMC-3270.

The following is a sample implementation:

```
public void addListener( FLB_NVAppListener listener ){

    this.listener = listener ;

}

public void closeDown(){

    //Your clean up code goes here.

}

public void removeListener( FLB_NVAppListener listener ){

    this.listener = null;

}
```

Finally, to notify the NMC-3270 of application termination you must code following in your termination or finalize routine:

```
listener.appClosing(this);
```

Building Host Access Class Library Applications

This section describes how to build a Java application which uses the Host Access Class Library (HACL). The source code preparation and compiling requirements are described.

Source Code Preparation

Programs that use HACL classes must import the HACL package to obtain class definitions and other compile-time information. The HACL package can be imported into a Java source file using the following statement:

```
import com.ibm.eNetwork.ECL.*;
import com.ibm.eNetwork.ECL.event.*;
import com.ibm.eNetwork.beans.HOD.*;
import src.ibmflb.*;
```

Compilation

To compile the new Java source file, the CLASSPATH must be updated to include the directory containing the HACL package. If HACL was installed in a Windows® environment, the CLASSPATH should already be updated. If HACL was not installed in a Windows environment, you will have to either update the CLASSPATH environment variable manually or use the '-classpath' parameter of the Java compiler, javac, to specify the location of HACL.

Running the HACL Application

The NetView 3270 management console provides two ways to load and run a user-defined application. A user application can be launched from the Execute HACL App dialog or as an Initial HACL App when a session is started. The Run Application dialog can be displayed from the toolbar. The dialog prompts for the name of a user-defined class (fully-qualified class name), constructs an instance of the class using the default constructor, and gives the class access to the current NetView session in the init method. If you do not know the class name you can use the find button to locate the class. In this instance the class will be freshly loaded. The Initial HACL App can be specified in the session configuration window.

Note: When an application that uses HACL is run, the directory containing the HACL package must be found in the path specified by the CLASSPATH environment variable.

Helper Class

The NetView 3270 management console provides a helper class to help an application writer get ECLSessions for various console sessions (for example, the hardware monitor and session monitor).

The following is a sample:

```
ECLSession session = FLB_HACLhelper.getSession("NPDA");
ECLPS ps = session.GetPS();
ECL0IA oia = session.Get0IA();
```

Sample Applications

The following two sample applications are shipped with the NetView 3270 management console (in the `examples` subdirectory):

- `FLB_HACLsample.java`
This sample enters the command `ald` in the input area of the screen.
- `FLB_ScreenSearchSample.java`
This sample searches for the word `alert` and responds with an `ALD` command.

Chapter 11. Designing HTML Files for the NetView Web Server

NetView provides a full-function Web application server that accepts commands through a Web browser interface, displays TCP/IP trace and SNMP data, and includes full online help. You can design HTML files for your own Web page.

Referencing Files and Commands

Most of the HTML for accessing NetView from the Web browser is dynamically generated by the NetView program and sent to the Web application server. Static elements such as style sheets are installed with the servlet code of the Web application server. This eliminates the need for network connections between the Web application server and the NetView host to retrieve frequently-accessed elements of the HTML.

The HTML (including user-written HTML) may be divided between the Web application server (workstation) and the NetView for z/OS host. This can include the following situations:

- Referencing host files from host HTML
- Referencing workstation files from host HTML
- Referencing host files from workstation HTML.

Understanding the Base URL

The following is a typical URL when browsing the NetView program:

```
http://httpost.example.com/netview/cnm01/
```

Therefore, the above is considered to be the *base URL*. If the URL contained a question mark, any remaining data is considered query data and is not considered to be part of the base URL.

Referencing Workstation Files on the Web Application Server

References to other sources should be relative to the base URL. For files on the Web application server, use `../` to back up to the `/netview/` directory.

Referencing NetView Host Files

When you design your own HTML files, use the following format:

DD name

```
DD/ddname/membername&DSIWSESSION.
```

DSN name

```
DSN/hq/mq/lq/membername&DSIWSESSION.
```

Where:

hq High-level data set qualifier name

mq Middle-level data set qualifier name

lq Low-level data set qualifier name

NetView supports the file type in the DD and DSN name. For these files, add *.type* to the end of the file name, for example:

```
DD/ddname/membername.gif
```

Typically, the base URL is as follows:
`http://httphost.example.com/netview/cnm01/`

Therefore, the DD and DSN names are appended to the base URL. For example, the complete URL becomes as follows:
`http://httphost.example.com/netview/cnm01/DD/DSIPARM/userhtm`

The supported file types are:

<i>.ext</i>	File type
.gif	GIF image
.jpeg	JPEG image
.jpg	JPEG image
.class	applet, element, or object
.mpeg	MPEG video
.mpe	MPEG video
.mpg	MPEG video
.js	Java script

For more examples, refer to FKXWPORF. Also, refer to FKXWB000 for examples of the frameset, help mapping, and title frame rewriter script.

Referencing NetView Commands

&DSIWBSESSION.?DSICMDS+==+command

Specifies the NetView command to be issued. Any blanks in the command must be specified as a plus sign (+) so that the command will be correctly parsed. The NetView Web server (DSIWBTSK) changes the plus signs to blanks before issuing the command. Refer to CNME2011 as an example.

Adding Links to the Portfolio

You can customize the NetView-supplied HTML file FKXWPORF to add links to your pages.

Note: If you change this NetView-supplied HTML file, use a %INCLUDE statement and place any new information in a separate file. Use the %INCLUDE statement for ease in migrating from release to release.

To add links to the portfolio, add a new section (for example, TCP/IP Support) to FKXWPORF similar to the following example:

```
<TR>
<TD nowrap COLSPAN=2>
<DIV class="weight">
<B>TCP/IP Support</B>
</DIV>
</TD>
</TR>
```

To add a new link to display in the main frame, insert the following:

```
<TR>
<TD nowrap>
&tdsp;&tdsp;
</TD>
```

```
<TD nowrap class="nonweight">  
<A target="mainFrame" href="&DSIWBSSESSION.?DSICMDS+++%25SP.FKXEDVST">DVIPA Status</A>  
</TD>  
</TR>
```

Loading Panels

To load a panel into the main frame of the Web browser, specify `target="mainFrame"` in the link. You must also change the title of the frame by adding the following:

```
<body ONLOAD="top.newtitle('New Title of Panel')">
```

If you want the HTML to run both inside and outside the frameset, code the following instead of as in the above example:

```
<script language="JavaScript">  
<!--//  
    if (top.window.name != window.name)  
        top.newtitle('New Title of Panel');  
//-->  
</script>
```

If you chose to place the added link inside the frameset, perform the following step if you want to add context-sensitive help. In the FKXWB000 file, add a case statement similar to the following for your help file:

```
case "Title of Your Panel": curhelp="yourhelp.html"  
    bottomFrame.location.reload(true)  
    break
```

The case statement above is based on the exact text of your title. While the .html help file is located on the server, use other FKXY* files to serve as examples of how to code the help file. Place your new file in the directory where the FKXY* files are located and then reference the file in the copied case statement above.

History Log

Each time a command is issued, the command and the corresponding response can be placed in the history log. To place the information in the log, you must invoke FKXEWLOG. Before invoking FKXEWLOG, create a named safe called MYWEBLOG.

In MYWEBLOG, the following conventions are required:

- Place the command issued and the results into MYWEBLOG, separated by a blank line. This will cause the provided information to be formatted similar to the output of the TCP/IP PING command.
- If no formatting is required or if preformatting (non-HTML formatting) has already occurred, then set the first line of MYWEBLOG to `<PRE>`. Named safes containing `<PRE>` will not be required to contain a blank line because all formatting must be provided by the calling function. HTML tags are not recommended within the `<PRE>` tags.

Using REXX to Generate HTML

NetView supports an interface similar to the Common Gateway Interface (CGI) for REXX procedures. Use the REXX function CGI () to determine whether your procedure was invoked by the NetView Web server. If CGI () returns 1, the procedure can create a dynamic Web page by ensuring that the beginning characters of the first line of output are either:

- <HTML
- <!DOCTYPE

Note: HTML and DOCTYPE must be in uppercase.

In this case, the NetView program does not modify or add to the output. It is recommended that you create output using the pipe stage CONSOLE ONLY to prevent the logging and automation of the HTML output. Refer to REXX part FKXEIPTR or HTML part FKXWI100 as examples for writing an HTML page.

Note: The CGI function is the preferred method to provide customization.

To improve performance, you can place static HTML or binary files on the Web application server.

Security Token

Use the security token &DSIWSESSION. to track the browser session and perform security. This token is passed between the browser and the Web application server.

The security token will be substituted by the NetView program with the actual security token that is in use between the current browser and the Web application server. This token should only be used in HTML that is generated in, or that resides in, the NetView program. This token should not be coded in static HTML that is installed at the Web application server.

The security token is only used when URL rewriting is used for session tracking. Refer to the *Tivoli NetView for z/OS Security Reference* for more information about session tracking.

If you only use cookies for session tracking in your environment, then this token is not required. When cookies are used and this token is coded, then the token will be removed by the NetView program. If any web browsers have cookies disabled, then the token is required to be coded, or web pages will not be displayed properly to users who have cookies disabled.

Migrating Web Browser Support

In NetView V1R3 and V1R4, in order for the NetView program to track the browser session and perform security, the token &DSIWSESIDF. was required in any HTML sent to the browser from NetView. For example:

```
DD&&DSIWSESIDF./ddname/membname
```

This token is no longer required because NetView no longer tracks the browser sessions. Tracking of browser sessions has been moved to the Web application server. If the NetView program encounters this token, it will be removed and the HTML will be treated as if the token did not exist.

A new security token is now used; however, this new token is not an exact replacement for the old token. The new token is &DSIWSESSION. and is only required if you are using URL rewriting for session tracking between the browser and the Web application server. The new token is placed in different locations, depending on the reference type. See the following examples.

The following example is a command reference on the host:

```
<A target="mainFrame" href="&DSIWSESSION.?DSICMDS+=+%25SP.FKXEDVST">DVIPA Status</A>
```

The following example is a reference to a server-side application:

```
<A target="mainFrame" href=" ../snmpcliserlet/&DSIWSESSION.?znvDomain=NTV74">SNMP  
Commands</A>
```

Both of these references are based off the base URL.

For more information about this new token and URL rewriting, refer to the *Tivoli NetView for z/OS Security Reference*. Refer to the FKXWPORF file for examples of opening full screen windows outside of the frameset.

Note: If you are using session cookies or referencing server files (for example, HTML or CSS file types), &DSIWSESSION. is not required.

When referencing the source of a command on host NetView, the security token is listed first. For example:

```
<...src="&DSIWSESSION.?DSICMDS+=+%25SP.FKXEIGEN+FKXWPORF">
```

When referencing a panel on host NetView, the security token is listed last. For example:

```
<...src="DD/CNMPNL1/FKXWELCM&DSIWSESSION.">
```

Submissions of forms also require the security token. The <FORM> attribute must be coded with the following action keyword:

```
<FORM METHOD="POST" action="&DSIWSESSION." NAME="fkxwcust" class="monotypeFont">
```

Form data is sent to the host through the server as a set of name-type pairs. For example, a pair of radio buttons would be coded as follows:

```
<FORM METHOD="POST" action="&DSIWSESSION." NAME="FKXWMYCD">  
<INPUT TYPE="HIDDEN" VALUE="FKXETEST" NAME="COMMAND">  
<INPUT TYPE="RADIO" SELECTED NAME="HAPPY" VALUE="NO">  
No:<INPUT TYPE="RADIO" NAME="HAPPY" VALUE="YES">  
Yes:
```

If the form containing the above statements is submitted to the host, the command FKXETEST would be invoked. In this example, FKXETEST is coded in REXX and would execute the following REXX PIPE:

```
'PIPE (NAME GRABPARM) ',  
'SAFE *',  
'SEPARATE',  
'EDIT /=/ 1 1. * N',  
'VARLOAD'
```

In this example, the REXX local variable HAPPY will be set with a value of either YES (the default) or NO, depending on if or which radio button was selected.

Appendix A. Color Maps for Hardware Monitor Panels

Table 20 lists the panel name, panel number, and color map for hardware monitor panels. See “Chapter 6. Customizing Hardware Monitor Displayed Data” on page 75 for more information on color maps.

Note: Color maps for hardware monitor help and command description panels are available only in prior releases of NetView. Also, color maps beginning with BNJMP1 are no longer supported.

Table 20. Color Maps for Hardware Monitor Panels

Panel Name	Panel Number	Color Map
Alerts-Dynamic	NPDA-30A	BNJMP30A
Alerts-History	NPDA-31A	BNJMP31A
Alerts-Static	NPDA-30B	BNJMP30A
Common Format Glossary	NPDA-02C	BNJMP2C1
Controller Information Display	NPDA-02E	BNJMP02E
Controller (CTRL) Selection Menu	NPDA-CTRL	BNJMPCTL
Downstream Member of Token-Ring LAN Fault Domain	NPDA-44B	BNJMP4BH
DSU/CSU and Line Status DSU/CSU and Line Parameters Link Segment Level <i>n</i>	NPDA-22C, page 1	BNJMPDL1
DSU/CSU and Line Status Remote DSU/CSU Interface-Remote Device Status-Link Segment Level <i>n</i>	NPDA-22C, page 2	BNJMPDL2
DSU/CSU and Line Status Configuration Summary, Link Segment Level <i>n</i>	NPDA-22C, page 3	BNJMPDL3
Event Detail	NPDA-43B	BNJMP43B
Event Detail	NPDA-43M	BNJMP43M
Event Detail	NPDA-43N, 43Q	BNJMP43N
Event Detail	NPDA-43C	BNJMP43C
Event Detail	NPDA-43T	BNJMP43T
Event Detail	NPDA-43A	BNJMP43A
Event Detail	NPDA-43P NPDA-43S	BNJMP43P BNJMP43S
Event Detail	NPDA-43T NPDA-43S	BNJMP434 BNJMP433
Event Detail, alternate		
Event Detail, alternate		
Event Detail for BSC Line	NPDA-43T NPDA-43T	BNJMP43T BNJMP43T
Event Detail for BSC Station	NPDA-43B NPDA-43B	BNJMP43B BNJMP43B
Event Detail for BSC/SS Line	NPDA-43B	BNJMP43B
Event Detail for BSC/SS Station		
Event Detail for Channel-Attached Station		
Event Detail for Channel Link	NPDA-43B NPDA-43J	BNJMP43B BNJMP43J
Event Detail for Instruction Exception	NPDA-43K	BNJMP43D
Event Detail for Miscellaneous Interrupts	NPDA-43G	BNJMP43D
Event Detail for Scanner-Type 1/4	NPDA-43H	BNJMP43D
Event Detail for Scanner-Type 2/3		
Event Detail for Scanner-Type 1	NPDA-43D	BNJMP43D
Event Detail for Scanner-Type 2	NPDA-43E NPDA-43F	BNJMP43D
Event Detail for Scanner-Type 3	NPDA-43I NPDA-43P	BNJMP43D
Event Detail for Scanner-Type 4		BNJMP43D
Event Detail for SDLC Line		BNJMP43B

Color Maps

Table 20. Color Maps for Hardware Monitor Panels (continued)

Panel Name	Panel Number	Color Map
Event Detail for SDLC Line	NPDA-43T NPDA-43B	BNJMP43T BNJMP43B
Event Detail for SDLC Station	NPDA-43T NPDA-43L	BNJMP43T BNJMP43L
Event Detail for SDLC Station	NPDA-43R	BNJMP43R
Event Detail for 3270 Non-SNA Controller	NPDA-43R	BNJMP43R
Event Detail Menu Event Detail Menu		
Event Detail Menu, alternate	NPDA-43R	BNJMP432 BNJMP43R
Event Detail Menu for BSC Line	NPDA-43R NPDA-43T	BNJMP434 BNJMP43R
Event Detail Menu for BSC Line, alternate	NPDA-43R NPDA-43T	BNJMP434
Event Detail Menu for BSC Station		
Event Detail Menu for BSC Station, alternate		
Event Detail Menu for SDLC Line Event	NPDA-43R NPDA-43T	BNJMP43R BNJMP434
Detail Menu for SDLC Line, alternate	NPDA-43R NPDA-43T	BNJMP43R BNJMP434
Event Detail Menu for SDLC Station	NPDA-42A	BNJMP42A
Event Detail Menu for SDLC Station, alternate		
Event Summary		
Event Summary	NPDA-42B	BNJMP42B
Event Summary	NPDA-42C (many	BNJMP42C
Glossary displays	displays) NPDA-44C	BNJMPGLO
HELP Menu	NPDA-02B	BNJMP44C
Hexadecimal Display of Error Record		BNJMP02B
Line Analysis-Link Segment Level <i>n</i>	NPDA-24B	BNJMPLNA
Link Configuration	NPDA-44A1	BNJMP441 BNJMP442
Link Configuration	NPDA-44A2	BNJMP443
Link Configuration, alternate	NPDA-44A1	
Link Configuration Summary-Level Selection	NPDA-LSLS	BNJMPLSL
Link Data for SNA Controller	NPDA-23A	BNJMP23A
Link Problem Determination Aid (LPDA-1) Data	NPDA-52A	BNJMP52A
Link Problem Determination Aid (LPDA-1) LDM Data	NPDA-52AL	BNJMP52L
(LPDA-2) Data Link Segment Level 1	NPDA-52B	BNJMP52B
(LPDA-2) Data Link Segment Level 1, alternate	NPDA-52B	BNJMP522
(LPDA) Data Link Segment Level 2	NPDA-52C	BNJMP52B
Link Status and Test Results	NPDA-24A	BNJMP24A
Link Status and Test Results for LDM	NPDA-24AL	BNJMP24L BNJMPLP1
LPDA-1 Command Menu	NPDA-LPDA1	BNJMPLP2
LPDA-2 Command Menu	NPDA-LPDA2	BNJMP01A
Menu	NPDA-01A	
Modem and Line Status Modem and Line Parameters Link Segment Level <i>n</i>	NPDA-22B, page 1	BNJMPML1
Modem and Line Status Remote Modem Interface-Remote Device Status-Link Segment Level <i>n</i>	NPDA-22B, page 2	BNJMPML2
Modem and Line Status Configuration Summary, Link Segment Level <i>n</i>	NPDA-22B, page 3	BNJMPML3
Most Recent Events	NPDA-41A	BNJMP41A
Most Recent Statistical Data	NPDA-51E NPDA-51F	BNJMP51E BNJMP51F
Most Recent Statistical Data	NPDA-51G	BNJMP51G
Most Recent Statistical Data	NPDA-51H NPDA-51I	BNJMP51H BNJMP51I
Most Recent Statistical Data		

Table 20. Color Maps for Hardware Monitor Panels (continued)

Panel Name	Panel Number	Color Map
Most Recent Statistical Data	NPDA-51B	BNJMP51B BNJMP51B
Most Recent Statistical Data for Printer	NPDA-51D	BNJMP51B
Most Recent Statistical Data for Tape	NPDA-51C	BNJMP51A
Most Recent Traffic Statistics	NPDA-51A	BNJMP51A
Most Recent Traffic Stats for BSC/SS Station	NPDA-51A	
Most Recent Traffic Stats for BSC STA. w/LPDA	NPDA-51A	BNJMP51A
Most Recent Traffic Stats for Channel Attached STA	NPDA-51A	BNJMP51A
Most Recent Traffic Stats for Local CTRL	NPDA-51A	BNJMP51A
Most Recent Traffic Stats for SDLC Station	NPDA-51A NPDA-51A	BNJMP51A BNJMP51A
Most Recent Traffic Stats for SDLC STA. w/LPDA	NPDA-70A (all displays)	BNJMP70A
Multiple Entries for Selected Resource Overwrite Map		BNJOVERW
Recommended Action for Selected Event	NPDA-BNlxxxxyyy	BNJMP45A
Recording and Viewing Filter Status	NPDA-20A,20B	BNJMP20A
Release Level for SNA Controller	NPDA-21A	BNJMP21A
Remote DTE Interface Status	NPDA-25A	BNJMP25A
Remote DTE Interface Status for LDM	NPDA-25AL	BNJMP25A
Remote Self-Test Results	NPDA-22A	BNJMP22A
Remote Self-Test Results for LDM	NPDA-22AL	BNJMP22L BNJMP44B
Reported Resource Hardware	NPDA-44B NPDA-44B	BNJMP4BS
Reported Resource Software Product	NPDA-02A, page 1	BNJMP2A1
Screen Control/Help	NPDA-02A, page 2	BNJMP2A2
Screen Control/Help		
Sender Hardware Product ID	NPDA-44B NPDA-44B	BNJMP4BH
Sender Software Product ID	NPDA-54D	BNJMP4BS BNJMP54I
Statistical Counter Detail Display, page 1	NPDA-54D	BNJMP54N
Statistical Counter Detail Display, page <i>n</i>	NPDA-53E NPDA-53F	BNJMP53E BNJMP53F
Statistical Detail	NPDA-53KA	BNJMP53K
Statistical Detail	NPDA-53R	BNJMP43R
Statistical Detail Display for Ethernet		
Statistical Detail Menu		
Statistical Detail	NPDA-53R	BNJMP43R
Menu for BSC	NPDA-53R	BNJMP43R
Statistical Detail Menu for SDLC	NPDA-02D	BNJMP02D
TEST Information Display	NPDA-40A	BNJMP40A
Total Events	NPDA-50A	BNJMP50A
Total Statistical Data		
Transmit Receive	NPDA-25B NPDA-44B	BNJMPTRT
Test-Link Segment Level <i>n</i>		BNJMP4BH
Upstream Member of Token-Ring Fault Domain		

Color Maps

Appendix B. NetView Macros and Control Blocks

The macros and control blocks identified in this appendix are provided by the NetView program as programming interfaces for customers.

Attention: Do not use as programming interfaces any NetView macros other than those identified in this appendix.

General-Use Programming Interface Control Blocks and Include Files

The following control blocks and include files are provided as general-use programming interfaces.

Name	Use
DSIBC	NetView Bridge HLL C include file
DSIBCCALL	NetView Bridge HLL C service routine definition
DSIBCCNM	NetView Bridge HLL C return codes
DSIBCHLB	NetView Bridge HLL C mapping of DSIHLB
DSIBPCNM	NetView Bridge HLL PL/I return codes
DSIBPHLB	NetView Bridge HLL PL/I mapping of DSIHLB
DSIBPHLS	NetView Bridge HLL PL/I service routine definitions
DSIBPLI	NetView Bridge HLL PL/I include file
DSIC	Main HLL C include file
DSICCALL	HLL C service routine definitions
DSICCNM	HLL C return codes
DSICCONS	HLL C constants
DSICHLB	HLL C mapping of DSIHLB
DSICORIG	HLL C origin block mapping
DSICPRM	HLL C NetView bridge parameter block
DSICVARC	HLL C varying length character strings
DSIPCNM	HLL PL/I return codes
DSIPCONS	HLL PL/I constants
DSIPHLB	HLL PL/I mapping of DSIHLB
DSIPHLLS	PL/I definitions for HLL service routines
DSIPLI	Main HLL PL/I include file
DSIPORIG	HLL PL/I origin block mapping
DSIPPRM	HLL PL/I NetView bridge parameter block
EKG1ACCB	PL/I RODM access block
EKG1ENTB	PL/I RODM entity access information block
EKG1FLDB	PL/I RODM field access information block
EKG1IADT	PL/I abstract data types
EKG1IEEP	PL/I external entry point declaration
EKG1IINC	PL/I include statements
EKG1LOGT	PL/I log record type definitions
EKG1TRAB	PL/I RODM transaction information block
EKG11101	PL/I function block for EKG_Connect
EKG11102	PL/I function block for EKG_Disconnect
EKG11201	PL/I function block for EKG_Checkpoint
EKG11202	PL/I function block for EKG_Stop
EKG11302	PL/I function block for EKG_CreateClass
EKG11303	PL/I function block for EKG_DeleteClass
EKG11304	PL/I function block for EKG_CreateField
EKG11305	PL/I function block for EKG_DeleteField

NetView Macros and Control Blocks

Name	Use
EKG11306	PL/I function block for EKG_CreateSubfield
EKG11307	PL/I function block for EKG_DeleteSubfield
EKG11401	PL/I function block for EKG_ChangeField
EKG11402	PL/I function block for EKG_SwapField
EKG11403	PL/I function block for EKG_ChangeSubfield
EKG11404	PL/I function block for EKG_SwapSubfield
EKG11405	PL/I function block for EKG_LinkTrigger
EKG11406	PL/I function block for EKG_LinkNoTrigger
EKG11407	PL/I function block for EKG_UnLinkTrigger
EKG11408	PL/I function block for EKG_UnLinkNoTrigger
EKG11409	PL/I function block for EKG_CreateObject
EKG11410	PL/I function block for EKG_DeleteObject
EKG11411	PL/I function block for EKG_RevertToInherited
EKG11412	PL/I function block for EKG_AddNotifySubscription
EKG11413	PL/I function block for EKG_DeleteNotifySubscription
EKG11415	PL/I function block for EKG_TriggerNamedMethod
EKG11416	PL/I function block for EKG_TriggerOIMethod
EKG11417	PL/I add object deletion notification subscription
EKG11418	PL/I delete object deletion notification subscription
EKG11501	PL/I function block for EKG_QueryField
EKG11502	PL/I function block for EKG_QuerySubfield
EKG11503	PL/I function block for EKG_QueryEntityStructure
EKG11504	PL/I function block for EKG_QueryFieldStructure
EKG11505	PL/I function block for EKG_QueryFieldID
EKG11506	PL/I function block for EKG_QueryFieldName
EKG11507	PL/I function block for EKG_QueryNotifyQueue
EKG11508	PL/I query multiple subfields
EKG11509	PL/I locate
EKG11510	PL/I function block for EKG_QueryResponseBlockOverflow
EKG11600	PL/I function block for EKG_ExecuteFunctionList
EKG12001	PL/I function block for EKG_QueryFunctionBlockContents
EKG12002	PL/I function block for EKG_LockObjectList
EKG12003	PL/I function block for EKG_UnlockAll
EKG12004	PL/I function block for EKG_ResponseBlock
EKG12005	PL/I function block for EKG_SendNotification
EKG12006	PL/I function block for EKG_SetReturnCode
EKG12007	PL/I function block for EKG_WhereAmI
EKG12008	PL/I function block for EKG_OutputToLog
EKG12009	PL/I function block for EKG_MessageTriggeredAction
EKG12011	PL/I function block for EKG_QueryObjectName
EKG21415	PL/I response block for EKG_TriggerNamedMethod
EKG21416	PL/I response block for EKG_TriggerOIMethod
EKG21501	PL/I response block for EKG_QueryField
EKG21502	PL/I response block for EKG_QuerySubfield
EKG21503	PL/I response block for EKG_QueryEntityStructure
EKG21504	PL/I response block for EKG_QueryFieldStructure
EKG21505	PL/I response block for EKG_QueryFieldID
EKG21506	PL/I response block for EKG_QueryFieldName
EKG21507	PL/I response block for EKG_QueryNotifyQueue
EKG21508	PL/I query multiple subfields
EKG21509	PL/I locate
EKG21510	PL/I response block for EKG_QueryResponseBlockOverflow
EKG22001	PL/I response block for EKG_QueryFunctionBlockContents
EKG22007	PL/I response block for EKG_WhereAmI

NetView Macros and Control Blocks

Name	Use
EKG22011	PL/I response block for EKG_QueryObjectName
EKG3ACCB	C/370™ RODM access block
EKG3CADT	C/370 RODM abstract data types
EKG3CEEP	C/370 external entry point declaration
EKG3CINC	C/370 include statements
EKG3CLOG	C/370 log record definitions
EKG3ENTB	C/370 RODM entity access information block
EKG3FLDB	C/370 RODM field access information block
EKG3TRAB	C/370 RODM transaction information block
EKG31101	C/370 function block for EKG_Connect
EKG31102	C/370 function block for EKG_Disconnect
EKG31201	C/370 function block for EKG_Checkpoint
EKG31202	C/370 function block for EKG_Stop
EKG31302	C/370 function block for EKG_CreateClass
EKG31303	C/370 function block for EKG_DeleteClass
EKG31304	C/370 function block for EKG_CreateField
EKG31305	C/370 function block for EKG_DeleteField
EKG31306	C/370 function block for EKG_CreateSubfield
EKG31307	C/370 function block for EKG_DeleteSubfield
EKG31401	C/370 function block for EKG_ChangeField
EKG31402	C/370 function block for EKG_SwapField
EKG31403	C/370 function block for EKG_ChangeSubfield
EKG31404	C/370 function block for EKG_SwapSubfield
EKG31405	C/370 function block for EKG_LinkTrigger
EKG31406	C/370 function block for EKG_LinkNoTrigger
EKG31407	C/370 function block for EKG_UnLinkTrigger
EKG31408	C/370 function block for EKG_UnLinkNoTrigger
EKG31409	C/370 function block for EKG_CreateObject
EKG31410	C/370 function block for EKG_DeleteObject
EKG31411	C/370 function block for EKG_RevertToInherited
EKG31412	C/370 function block for EKG_AddNotifySubscription
EKG31413	C/370 function block for EKG_DeleteNotifySubscription
EKG31415	C/370 function block for EKG_TriggerNamedMethod
EKG31416	C/370 function block for EKG_TriggerOIMethod
EKG31417	C/370 add object deletion notification subscription
EKG31418	C/370 delete object deletion notification subscription
EKG31501	C/370 function block for EKG_QueryField
EKG31502	C/370 function block for EKG_QuerySubfield
EKG31503	C/370 function block for EKG_QueryEntityStructure
EKG31504	C/370 function block for EKG_QueryFieldStructure
EKG31505	C/370 function block for EKG_QueryFieldID
EKG31506	C/370 function block for EKG_QueryFieldName
EKG31507	C/370 function block for EKG_QueryNotifyQueue
EKG31508	C/370 query multiple subfields
EKG31509	C/370 locate
EKG31510	C/370 function block for EKG_QueryResponseBlockOverflow
EKG31600	C/370 function block for EKG_ExecuteFunctionList
EKG32001	C/370 function block for EKG_QueryFunctionBlockContents
EKG32002	C/370 function block for EKG_LockObjectList
EKG32003	C/370 function block for EKG_UnlockAll
EKG32004	C/370 function block for EKG_ResponseBlock
EKG32005	C/370 function block for EKG_SendNotification
EKG32006	C/370 function block for EKG_SetReturnCode
EKG32007	C/370 function block for EKG_WhereAmI

NetView Macros and Control Blocks

Name	Use
EKG32008	C/370 function block for EKG_OutputToLog
EKG32009	C/370 function block for EKG_MessageTriggeredAction
EKG32011	C/370 function block for EKG_QueryObjectName
EKG41415	C/370 response block for EKG_TriggerNamedMethod
EKG41416	C/370 response block for EKG_TriggerOIMethod
EKG41501	C/370 response block for EKG_QueryField
EKG41502	C/370 response block for EKG_QuerySubfield
EKG41503	C/370 response block for EKG_QueryEntityStructure
EKG41504	C/370 response block for EKG_QueryFieldStructure
EKG41505	C/370 response block for EKG_QueryFieldID
EKG41506	C/370 response block for EKG_QueryFieldName
EKG41507	C/370 response block for EKG_QueryNotifyQueue
EKG41508	C/370 query multiple subfields
EKG41509	C/370 locate
EKG41510	C/370 response block for EKG_QueryResponseBlockOverflow
EKG42001	C/370 response block for EKG_QueryFunctionBlockContents
EKG42007	C/370 response block for EKG_WhereAmI
EKG42011	C/370 response block for EKG_QueryObjectName
FLBTREM	C/370 exception view update parameter structure
FLBTRSM	C/370 status change parameter structure

The following macros are provided as general-use programming interfaces.

Name	Use
CNMALTDATA	Alter data on a queue
CNMAUTOTAB	Invoke automation table
CNMCLOSMEM	Close NetView partitioned data set
CNMCODE2TXT	Code point translation
CNMCOMMAND	Invoke NetView commands
CNMCOPYSTR	Copy storage
CNMETINIT	Initialize the server support
CNMETNEXT	Get next transaction request
CNMETQUIESCE	Quiesce the database
CNMETREADY	Ready for next transaction
CNMETRPARM	Get transaction request
CNMETTERM	Terminate the Server support
CNMETWAIT	Wait for a transaction request
CNMGETATTR	Query message attributes
CNMGETDATA	Data queue manipulation
CNMGETPARM	Get transaction reply parameters
CNMHREGIST	High performance transport application registration
CNMHSENDMU	Send high performance message unit
CNMI	CNMI access under a DST
CNMINFOC	Query NetView character information
CNMINFOI	Query NetView integer information
CNMKEYIO	Keyed file access under a DST
CNMLOCK	Control a lock
CNMNAMESTR	Named storage
CNMOPENMEM	Open NetView partitioned data set
CNMOPREP	Resource object data manager
CNMPRSMDB	Process message data block
CNMREADMEM	Read NetView partitioned data set
CNMREGIST	Application registration
CNMSCOPECK	Check command authorization for security

Name	Use
CNMSSENDMSG	Send message or command
CNMSSENDMU	Send message unit
CNMSSENDSTR	Send transaction replay to NetView requester
CNMSENDTR	Send transaction request to database server
CNMSSCAN	Parse or convert character string
CNMSTRCELL	Storage cell
CNMSTRPOOL	Storage pool
CNMVARPOOL	Set or retrieve variables
DUIFEDST	Assembler macro

Product-Sensitive Programming Interfaces

The following control blocks are provided as product-sensitive programming interfaces.

Name	Use
AAUTISAW	Internal session awareness record
AAUTLOGR	Structure map for NetView SMF log record
BNJTBRF	Batch record format table
DSIAIFRO	Automation internal function request object extension vector
DSIASYPN	Asynchronous panel parameter list
DSICBH	Control block header
DSICWB	Command work block
DSIDSB	Data services block
DSIDSRB	Data services request block
DSIDTR	Data transport Request block
DSIELB	External logging block
DSIID	NetView level identifier
DSIIFR	Internal function request
DSILOGDS	NetView log DSECT
DSIMVT	Main vector table
DSIPDB	Parse descriptor block
DSISCE	System command entry
DSISCT	System command table (include only)
DSISVL	Service routine vector list (include only)
DSISWB	Service work block
DSITECBR	Branch table of ECB processor load module
DSITIB	Task information block
DSITVB	Task vector block
DSIUSE	Installation exit parameter list
DUIRXCM	RSM resource command support for XITCM exit
DUITSTAT	RSM resource status information for XITST exit

The following macros are provided as product-sensitive programming interfaces.

Name	Use
DSIAUTO	Automation services
DSIBAM	Build automation message
DSIBAMKW	Build automation message keyword
DSICBS	Control block services
DSICES	Command entry services
DSICVTHE	Convert to hex
DSIC2T	Translate alert code point to text

NetView Macros and Control Blocks

Name	Use
DSIDATIM	Date and time
DSIDEL	Delete user-defined module
DSIDKS	Disk services
DSIFIND	Find long-running command storage
DSIFRE	Free storage
DSIFREBS	Free buffer structure service
DSIGET	Get storage
DSIGETDS	Retrieve messages
DSIHREGS	High-performance registration
DSIHSNDS	High-performance send
DSIKVS	Keyword/value services
DSILCS	Obtain/release control blocks
DSILOD	Load user-defined module
DSIMBS	Message buffer services
DSIMDS	Message definition services
DSIMMDBS	Message data block service
DSIMQS	Message queuing services
DSINOR	Resource object data manager d
DSIPAS	Parameter/alias services
DSIPOP	Remove long-running command
DSIPOS	ECB post services
DSIPRS	Parsing services
DSIPSS	Presentation services
DSIPUSH	Establish long-running command
DSIQOS	Query operator services
DSIQRS	Query resource services
DSIRDS	Resource definition services
DSIRXCOM	Access REXX variables (VM only)
DSIRXEBS	Get an EVALBLOK
DSISRCMV	Search for subvector/subfield
DSISYS	Operating system indicator
DSITECBS	Manage a dynamic ECB list for DSTs
DSIVARS	Global Variable Access
DSIWAT	ECB wait services
DSIWCS	Write console services
DSIWLS	Write log services
DSIZCSMS	CNM data services
DSIZVSMS	VSAM data services
DSI6REGS	Registration services
DSI6SNDS	Send services

Index

Special Characters

&CGLOBAL 40
&CUR 32, 54
&SUPPCHAR 46
&TGLOBAL 40
&VIEWAID 47
&VIEWCOLS 49
&VIEWCURCOL 47
&VIEWCURROW 47
&VIEWICCOL 47
&VIEWICROW 47
&VIEWROWS 49
&WAIT 108

A

access method 5, 12
accessibility information ix
ACTION command list 81, 85
ACTION statement, SCRNFMFMT 26
activate screen format definition 25
actual panel name
 adding 79
 changing panel text 78
adding functions 3
adding links
 Web application server 172
AID (attention identification)
 information 47
alert adapter service
 event/automation service 111
alert-to-trap service
 event/automation service 111
alerts
 description 1, 91
 generic
 build panel 92
 description 91
 modify 75
 NMVT 90
 recommended action code
 point 83
 record 75
 reference documentation, table 4
 sample record 92
 Tivoli-supplied alert table 92
 message 75
 nongeneric
 messages 80
 migration purposes 90
 modify 75
 sender 85
 user-defined 90, 91
Alerts-Dynamic panel 80
Alerts-History panel 75, 80
Alerts-Static panel 75, 80
alias names
 definition 1
 reference documentation, table 4

alias panel name
 adding 79
 determining 75, 76
application, performance-critical 13
application management
 instrumentation 159
APPLID NetView control variable 41
assembled command procedure 13
attribute
 symbols 35
 variables 37
audible alarm 85
automated operations
 definition 1
 NetView automation 1
automation table
 setting message color and
 highlighting 28
 VPDXDOM command list 106, 107
autotask 109

B

BGNSESS FLSCN command 43
block ID 76
BNJALxxx sample table 78
BNJBLKID sample table 77
BNJDNUMB 82
BNJDSERV task 103
BNJPNL2 DD statement 84
BNJPNL2 definition statement 102
BNJPROMP (prompt highlight token
 table) 89
BNJRESTY member 102
BNJwwwwww code point members 84
books
 feedback viii
 online viii
 ordering viii
BROWSE command, view help 64

C

CANCEL option, UNIQUE command 46
class definition statement files 123
CMD command 44
CMD HIGH 54
CMDLINE statement, SCRNFMFMT 28
CNM944I message 40
CNMI service 5, 12
CNMKEYS, modifying 24
CNMPNL1 DD statement 68
CNMS1101 sample 57
CNMSRESP source panel example 59
CNMSTYLE 159
CNMVARs 40
code, VIEW command 32
code point
 alert description (BNJ92UTB) 99
 description 1

code point (*continued*)
 detail data (BNJ82UTB) 99
 failure cause (BNJ96UTB) 99
 install cause (BNJ95UTB) 99
 probable cause (BNJ93UTB) 99
 recommended action (BNJ81UTB) 84,
 99
 user cause (BNJ94UTB) 99
color, panel text 29
color and highlighting fields, control 35
color buffer 86, 89
color maps
 BNJOVERW 86
 hardware monitor panel 177
 list 177
 map element 86
 repetition factor option 88
 repetition map element 88
 sample 87
 variable row 88
column headings, NCCF panel
 control tags, PREFIX and NOPREFIX
 statements 26
 customizing, COLUMNHEAD
 statement 26
COLUMNHEAD statement,
 SCRNFMT 26
command area, NCCF panel 28
command buffers 9
command entry indicator, NCCF
 panel 28
command facility console 103
command facility panel, customizing 25
command facility panel attributes 25
command help
 copying 64
 locating source files 63
 modifying 67
 storing 68
command line 54
command lists
 error message 106
 modifying 33
 variable 6, 32
 writing 33
command procedure, issuing 43
command processor, interface 9, 11
commands
 data services 10
 immediate 9
 long-running 9
compiled language 13
compound symbols in source panels 42
concatenated user library 91
control blocks
 access 13
 general-use 181
 product-sensitive 181
control program text title 99
control variable 40, 41
CREATE option 106

- current date area, NCCF panel 26
- Customer Support ix
- customization, areas 1
- customizing 25
 - CNMKEYS 24
 - IBM-supplied VPD command list 108
- immediate message line 23
- NCCF panel 25
 - CMDLINE statement 28
 - column headings 26
 - COLUMNHEAD statement 26
 - command area 28
 - command entry indicator 28
 - current date area 26
 - domain id area 26
 - HELD, ACTION, NORMAL, and NQMAX statements 26
 - held and action message area 27
 - held messages, warning 27
 - HOLDPCNT statements 27
 - IMDAREA statement 28
 - immediate message area 28
 - INDENT and MLINDENT statements 28
 - indentation 28
 - LASTLINE statement 28
 - limitations 25
 - lock/unlock indicator 28
 - LOCKIND statement 28
 - operator id area 26
 - output area 26
 - separator line 28
 - status area 26
 - time area 26
 - title area 26
 - TITLE statement 26
 - TITLEDATE statement 26
 - TITLEDOMID statement 26
 - TITLEOPID statement 26
 - TITLESTAT statement 26
 - TITLETIME statement 26
- PF keys 23
- customizing hardware monitor displayed data
 - alert message 75, 80
 - color and highlighting
 - modifying color map 86
 - prompt highlight token 89
 - selecting color map 86
 - modifying hardware monitor panel
 - actual, alias panel name 75
 - adding actual or alias name 79
 - changing alias to actual 78
 - changing panel text 78
 - deleting actual or alias name 79
 - determining panel name 75
 - overlying recommended action number 81
 - user interface
 - BNJDNUMB 82
 - BNJwww 84
 - using NMVT support for user-written programming
 - adding or modifying resource type 102
 - building generic alert panel 92

- customizing hardware monitor displayed data (*continued*)
 - using NMVT support for user-written programming (*continued*)
 - modifying generic code point tables 99
 - table format 99

D

- data file 6
- data services task (DST) subtask 8
- DCE (data communication equipment) 105, 106
- DEFAULTS command, activate screen format definition 25
- designing functions
 - choosing languages
 - introduction 12
 - logging 15
 - performance 13
 - identifying conceptual component
 - adding optional task 8
 - collecting data 4
 - data file 5
 - data storage and record 6
 - defining transaction 10
 - exit and command 10
 - installation exit 5
 - operator command and message 6
 - operator presentation 6
 - service routine 5
 - task structure 7
 - designing HTML files
 - Web application server 171
- detail data code point 92
- direct NNT session 108
- direct OST session 108
- directory list of panel names 76
- disability information ix
- displayed data, hardware monitor 75
- displaying
 - special attributes 36
 - documentation for customizing 3
- domain id area, NCCF panel 26
- DRD (dynamic reconfiguration deck) 107
- DSIAMIAT 159
- DSIAMII 160
- DSIELTSK 107
- DSIMDS macro 81, 91
- DSIPOP 46
- DSIPUSH 43, 46
- DST (data services task) subtask 8
- dynamic reconfiguration deck (DRD) 107

E

- e-mail contact ix
- embed flag 102
- END record 106, 107
- event/automation service 111
 - configuration files 118
 - defaults 112

- event/automation service (*continued*)
 - overview 111
 - starting 112
- event detail panel 75, 76, 80
- event receiver service
 - event/automation service 111
- exit, installation 5
- exit routine, installation 13

F

- feedback about publications ix
- filter
 - definition 1
 - hardware monitor 1
 - messages 1
 - reference documentation, table 4
- focal point VPD collection 107
- full-screen panel, display 29
- functional extension 7
- functions, design and implement 1

G

- GENALERT command 92
- general-use programming interfaces 181
- generic alert code point 75
- generic alert record 75
- global variable 40, 57
- GLOBALV 40
- GO command 14
- group control system 7

H

- HALT subroutine 46
- hardware monitor panels
 - altering text
 - color 85
 - highlighting 85
 - intensity 85
 - audible alarm 85
 - displayed data 75
 - displays, list 177
 - mapping NMVT 90
 - modifying panel 75
 - name, determining 75
 - Recommended Action panel 81
- hardware product identifier 83
- held and action message area, NCCF panel 27
- held messages, NCCF panel warning 27
- HELD statement, SCRNFMT 26
- HELPDESK, changing 67
- HELPMAP, searching 68
- hierarchy complete 95
- highlight fields, control color 35
- highlight panel text 29
- history log
 - Web application server 173
- HOLDPCNT statement, SCRNFMT 27
- HOLDWARN statement, SCRNFMT 27
- host access class library 167

I

- IEBUPDTE utility 79
- IEHPROGM utility 79
- IHSAEVNT 112
- IMDAREA statement, SCRNFMT 28
- immediate message area, NCCF panel 28
- immediate message line, customizing 23
- indent, NCCF panel 28
- INDENT statement, SCRNFMT 28
- information, accessibility ix
- information, disability ix
- INITAMI 162, 165
- INITAMON 165
- input-capable
 - fields 49
 - INPUT 54
 - variable 47
- input field 52
- INPUT keyword 47
- input value 33
- installation exit
 - interface 4
 - programs 10
 - routine 5
 - routine. 13
 - setting message color and highlighting 28
- instrumentation 159
 - considerations 159
 - customizing 159
 - messages 159
 - starting 162
- instrumentation, stopping 162, 165
- inventory data, collecting 105

K

- keyboard, shortcut keys ix

L

- languages, choosing 12
- LASTLINE statement, SCRNFMT 28
- limitations
 - background message color, 3270 28
 - customizing NCCF panel 25
 - displaying held messages 27
 - NORMQMAX statement value 27
 - setting message default colors 26
- link-edit load module name 91
- LOADCL command 13
- loading panels
 - Web application server 173
- local variable, REXX 41
- lock/unlock indicator, NCCF panel 28
- LOCKIND statement, SCRNFMT 28
- logging facilities 6
- logging method 15
- LPDA-2 architecture 105

M

- macros, product-sensitive 185
- managing additional component 3

- manuals
 - feedback viii
 - online viii
 - ordering viii
- message adapter service
 - event/automation service 111
- message buffers 9
- message color default value, specifying, SCRNFMT 25
- message help
 - copying 64
 - locating source files 63
 - modifying 67
 - naming convention 63
 - storing 68
- messages
 - color and highlighting 28
 - default colors 26
 - held, NCCF panel warning 27
 - held and action area, NCCF panel 27
 - queued for later display 27
 - specifying infinite queues 27
- migration 90
- MINOR option 43
- MLINDENT statement, SCRNFMT 28
- modifying
 - CNMKEYS 24
 - existing function 3
 - immediate message line 23
 - online help
 - command 67
 - message 67
 - procedures 64
 - regular 67
 - PF keys 23
- modifying SPCS and NAM command lists
 - customization considerations 108
 - NAM command list 105
 - vital product data (VPD) collection
 - focal point NetView 107
 - single NetView domain 107
 - single physical unit 106
- most recent events panel
 - changing Event Description: Probable Cause text 80
 - identifying resources 75
- MSG option
 - dynamic update capabilities 56
 - RESOURCE command output usage 57
- MVS MPF table, setting message color and highlighting 28

N

- named variable 44
- naming convention
 - message help 63
- naming online help 68
- National Language Support (NLS)
 - kanji feature 2
 - message translations 2
 - reference documentation, table 4
- NCCF panel, customizing 25
- NetView
 - automation table 106, 107

NetView (*continued*)

- component, definition 44
- log 40
- panel library 91
- NetView 3270 management console
 - host access class library 167
- NetView command facility panel 25
- network
 - log 15
 - management data 5
 - qualified procedure correlation identifier 99
- network asset management (NAM)
 - command list
 - modifying 108
 - VPDACT command list 106
 - VPDDCE command list 106
 - VPDLOGC command list 106
 - VPDPU command list 106
 - VPDXDOM command list 106
 - new management function 3
 - new online help
 - creating 67
 - storing 68
 - structuring conventions 67
- NMVT (network management vector transport) 90
- NOINPUT option
 - creating rollable components 44
 - definition 33
 - displaying online help panels 33
 - return command line input 54
- NOMSG option 34
- nongeneric alerts 90
- NOPREFIX statement, SCRNFMT 26
- NORMAL statement, SCRNFMT 26
- NORMQMAX statement, SCRNFMT 26
 - extreme value, calling attention to minimum value 27
 - OST-NNT cross-domain sessions 27
 - printers 27
 - queueing messages for later display 27
 - specifying infinite queues 27
 - values 27

O

- online help
 - copying 64
 - creating new help 67
 - highlighting attributes 64
 - locating source files 63
 - modifying
 - command help 67
 - procedure 64
 - regular help 67
 - source 67
 - naming 68
 - organization 63
 - source 64
 - store procedures 68
 - writing 67
- online help panels
 - color attributes 36
 - highlighting attributes 36
- online publications viii

- operator command 6
- operator command interface 44
- operator control and security
 - command authorization 2
 - reference documentation, table 4
 - span of control 2
- operator id area, NCCF panel 26
- operator interface 7
- OPID NetView control variable 40, 41
- OPT (optional) subtask 8
- OPT task, adding 12
- ordering publications viii
- output area, NCCF panel 26
- OVERRIDE command, activate screen
 - format definition 25
- overwrite global variable 41

P

- panel
 - data stream 68
 - definition, using with VIEW 29
 - definition statement 40
 - hardware monitor 75
 - partitioned data set 63
 - record length 67
 - variables 37
- panels, loading
 - Web application server 173
- partial command, predefining 54
- PAUSE command 14
- performance 13
- PF keys, customizing 23
- PF keys, using with VIEW 55
- physical unit (PU) 105, 106
- PREFIX statement, SCRNFMT 26
- preload
 - NetView command list. 13
 - REXX command list 13
- probable cause code point 91
- product-sensitive
 - control blocks 181
 - macros 185
- product-set identification (PSID) 82
- program function keys, using with VIEW 55
- programming interfaces
 - general-use 181
 - product-sensitive 185
- PROMOTE option, UNIQUE
 - command 46
- prompt highlight token table 89
- PSID (product-set identification) 82
- publications
 - feedback viii
 - online viii
 - ordering viii

Q

- queueing commands 44

R

- recommended action number 81
- Recommended Action panel 75, 76

- record filters 1
- record format, building 108
- referencing commands
 - Web application server 171
- referencing files
 - Web application server 171
- regular help panel 63, 67, 68
- repetition factor option 88
- repetition map element 88
- REQUEST/REPLY PSID architecture 105
- RESDYN command list output
 - example 58
- RESET command 108
- RESOURCE command 57
- resource type
 - adding 102
 - modifying 102
- return codes 33, 34, 45, 47
- REXX function CGI
 - Web application server 174
- REXX-generated HTML
 - Web application server 174
- REXX programming language, local
 - variable 41
- ROLL command 43
- roll group 43, 46
- rollable component
 - creating 44
 - REXX command procedure that
 - drives 51

S

- screen format definition (SCRNFMT)
 - command facility panel attributes 25
 - customizable fields
 - COLUMNHEAD line 26
 - command area 28
 - command entry indicator 28
 - current date 26
 - domain identifier 26
 - held and action message area 27
 - immediate message area 28
 - indentation 28
 - lock/unlock indicator 28
 - operator identifier 26
 - output area 26
 - separator line 28
 - system states 26
 - time of last display 26
 - title area 26
 - message color default value 25
- SCRNFMT (screen format definition)
 - command facility panel attributes 25
 - customizable fields
 - COLUMNHEAD line 26
 - command area 28
 - command entry indicator 28
 - current date 26
 - domain identifier 26
 - held and action message area 27
 - immediate message area 28
 - indentation 28
 - lock/unlock indicator 28
 - operator identifier 26
 - output area 26
 - separator line 28

- SCRNFMT (screen format definition)
 - (continued)
 - customizable fields (continued)
 - system states 26
 - time of last display 26
 - title area 26
 - message color default value 25
 - SCRNFMT statements
 - ACTION 26
 - CMDLINE 28
 - COLUMNHEAD 26
 - HELD 26
 - HOLDPCNT 27
 - HOLDWARN 27
 - IMDAREA 28
 - INDENT 28
 - LASTLINE 28
 - LOCKIND 28
 - MLINDENT 28
 - NOPREFIX 26
 - NORMAL 26
 - NORMQMAX 26
 - PREFIX 26
 - TITLE 26
 - TITLEDATE 26
 - TITLEDOMID 26
 - TITLEOPID 26
 - TITLESTAT 26
 - TITLETIME 26
 - secondary extent 67, 85
 - security token
 - Web application server 174
 - sense code descriptions, customizing 71
 - separator line, NCCF panel 28
 - sequential data set 68
 - sequential logging
 - definition 2
 - reference documentation, table 4
 - service level reporter (SLR) 108
 - serviceable component identifier 83
 - session monitor data
 - definition 2
 - performance classes 2
 - reference documentation, table 4
 - response time monitor (RTM) 2
 - shortcut keys, keyboard ix
 - SHOWCODE command list 34
 - SMF log 5
 - SMF logging failure 106
 - SMF record format, changing 108
 - SMF record number 108
 - source, help
 - building 67
 - definition 64
 - locating 63
 - modifying 67
 - structure 67
 - viewing 64
 - source, helps
 - sample panel 30
 - specialized disk service 5, 12
 - START DOMAIN command 108
 - START record 106, 107
 - START VPDTASK 108
 - STARTCNM NPDA 103
 - status area, NCCF panel 26
 - STOP TASK 103

storing new or modified help 68
subcommands, VIEW 55
symbols, compound 42
system allocation 5, 12
system interface 7

T

task, operator station (OST) 7
task variable 14
TERMAMI 162
TERMAMON 165
tilde definition 54
time area, NCCF panel 26
title area, NCCF panel 26
TITLE statement, SCRNFMT 26
TITLEDATE statement, SCRNFMT 26
TITLEDOMID statement, SCRNFMT 26
TITLEOPID statement, SCRNFMT 26
TITLESTAT statement, SCRNFMT 26
TITLETIME statement, SCRNFMT 26
Tivoli Customer Support ix
Tivoli Enterprise Console
 customizing 162
transaction program
 command processor 10
 installation exit 10
trap-to-alert service
 event/automation service 111

U

UNIQUE command 33, 45
UPPER command 44
user-defined alert
 generic 91
 nongeneric 90
user interface
 BNJDNUMB 82
 BNJwwwwww 84
user subtask, writing 12
user table, defining
 BNJ81UTB 99
 BNJ82UTB 99
 BNJ92UTB 99
 BNJ93UTB 99
 BNJ94UTB 99
 BNJ95UTB 99
 BNJ96UTB 99
 sample 101
user-written functions
 definition 2
 reference documentation, table 4

V

variable row placement option 88
variables, compound 42
vector transport, network management
 (NMVT) 90
VIEW command, using 29
VIEW command processor
 attribute definition 35
 code 32
 creating rollable components 44
 definition statement 40

VIEW command processor (*continued*)
 displaying error messages 34
 displaying return codes 34
 displaying variables in source
 panels 40
 dynamic update capability 56
 finding global variables 40
 full-screen input capability 47
 global variable 40
 INPUT option 33
 input value 33
 issuing from command procedure 43
 managing command lines 59
 managing PF keys 59
 message data 33
 MSG option 56
 NOINPUT option 33
 panel definition
 attribute symbol 35
 attribute variable 37
 controlling color 35
 controlling highlighting 35
 return code 33
 return command line input 54
 subcommands 55
 using 29
 using PF keys 55
 using SHOWCODE command list 34
 using UNIQUE command 45
 using UPPER command 44
 VIEWAID variable 49
view filters 1
VIEWAID variable 49
VIEWCOLS variable 49
VIEWCURCOL variable 47
VIEWCURROW variable 47
VIEWICCOL variable 47, 48
VIEWICROW variable 47, 48
VIEWROWS variable 49
vital product data (VPD), definition 105
VPD command 106, 108
VPDACT command 106
VPDALL command 107
VPDDCE command entry 107
VPDLOGC command list 106, 107
VPDPU command entry 107
VPDTASK 106
VPDXDOM command list 106, 107
VSAM data service 5, 12
VTAM ACB Monitor
 starting 165
VTAM CNMI 5
VTAM configuration member in
 VTAMLST 106, 107
VTAMLST 106

W

Web application server
 adding links 172
 designing HTML files 171
 history log 173
 including references 175
 loading panels 173
 migration 174
 referencing files 171
 REXX function CGI 174

Web application server (*continued*)
 REXX-generated HTML 174
 security token 174

X

XVAR 31, 43



File Number: S370/4300/30XX-50
Program Number: 5697-ENV



Printed in the United States of America
on recycled paper containing 10%
recovered post-consumer fiber.

SC31-8859-00

